



SLOVENSKI STANDARD SIST EN 3081:2002

01-januar-2002

Aerospace series - Pipe coupling 8°30' in titanium alloy - Ferrules, welded with dynamic beam seal end, for repair

Aerospace series - Pipe coupling 8°30' in titanium alloy - Ferrules, welded with dynamic beam seal end, for repair

Luft- und Raumfahrt - Rohrverschraubung 8°30' aus Titanlegierung - Anschweißstutzen mit Dichtlippe, für Reparatur

Série aérospatiale - Systeme de raccordement 8°30' en alliage de titane - Olives a souder avec joint a levre, pour réparation

<https://standards.iteh.ai/catalog/standards/sist/1d51b10a-af28-4f42-b1bb-3539efdc26bc/sist-en-3081-2002>

Ta slovenski standard je istoveten z: EN 3081:2001

ICS:

49.080

Številni sistemi za povezavo cevi iz titanove zlitine s dinamično tesnilno cevjo za popravilo

Aerospace fluid systems and components

SIST EN 3081:2002

en

iTeh STANDARD PREVIEW
(standards.iteh.ai)

[SIST EN 3081:2002](#)

<https://standards.iteh.ai/catalog/standards/sist/1d51b10a-af28-4f42-b1bb-3539efdc26be/sist-en-3081-2002>

iTeh STANDARD PREVIEW
(standards.iteh.ai)

SIST EN 3081:2002

<https://standards.iteh.ai/catalog/standards/sist/1d51b10a-af28-4f42-b1bb-3539efdc26be/sist-en-3081-2002>

iTeh STANDARD PREVIEW
(standards.iteh.ai)

SIST EN 3081:2002

<https://standards.iteh.ai/catalog/standards/sist/1d51b10a-af28-4f42-b1bb-3539efdc26be/sist-en-3081-2002>

iTeh STANDARD PREVIEW
(standards.iteh.ai)

SIST EN 3081:2002

<https://standards.iteh.ai/catalog/standards/sist/1d51b10a-af28-4f42-b1bb-3539efdc26be/sist-en-3081-2002>

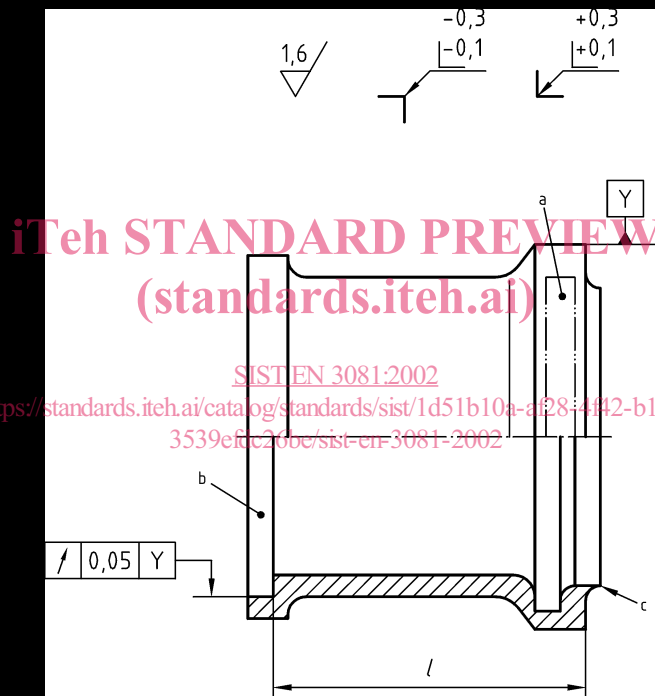

iTeh STANDARD PREVIEW
(standards.iteh.ai)

SIST EN 3081:2002

<https://standards.iteh.ai/catalog/standards/sist/1d51b10a-af28-4442-b1bb-3539efc206c/sist-en-3081-2002>

iTeh STANDARD PREVIEW (standards.iteh.ai)

SIST EN 3081:2002

<https://standards.iteh.ai/catalog/standards/sist/1d51b10a-af28-4f42-b11b-3539efdc26be/sist-en-3081-2002>

Description block

FERRULE, WELDED

Identity block

EN3081-0806

Number of this standard

Code (see table 1)