

INTERNATIONAL STANDARD

ISO
9243

First edition
1988-08-15



INTERNATIONAL ORGANIZATION FOR STANDARDIZATION
ORGANISATION INTERNATIONALE DE NORMALISATION
МЕЖДУНАРОДНАЯ ОРГАНИЗАЦИЯ ПО СТАНДАРТИЗАЦИИ

Pliers and nippers — Carpenter's pincers — Dimensions and test values

Pinces et tenailles — Tenailles de menuisier — Dimensions et valeurs d'essai

(standards.iteh.ai)

ISO 9243:1988

<https://standards.iteh.ai/catalog/standards/sist/f0ddbcbc-8fb5-4d06-9172-51188eea98d3/iso-9243-1988>

Reference number
ISO 9243 : 1988 (E)

Foreword

ISO (the International Organization for Standardization) is a worldwide federation of national standards bodies (ISO member bodies). The work of preparing International Standards is normally carried out through ISO technical committees. Each member body interested in a subject for which a technical committee has been established has the right to be represented on that committee. International organizations, governmental and non-governmental, in liaison with ISO, also take part in the work. ISO collaborates closely with the International Electrotechnical Commission (IEC) on all matters of electrotechnical standardization.

Draft International Standards adopted by the technical committees are circulated to the member bodies for approval before their acceptance as International Standards by the ISO Council. They are approved in accordance with ISO procedures requiring at least 75 % approval by the member bodies voting.

International Standard ISO 9243 was prepared by Technical Committee ISO/TC 29, *Small tools*.

<https://standards.iteh.ai/catalog/standards/sist/f0ddbcbc-8fb5-4d06-9172-51188eea98d3/iso-9243-1988>

Pliers and nippers — Carpenter's pincers — Dimensions and test values

iTeh STANDARD PREVIEW (standards.iteh.ai)

1 Scope

This International Standard specifies the principle dimensions of carpenter's pincers and the test values in order to verify their aptitude to function in conformity with ISO 5744.

It also specifies the minimum hardness of the cutting edge.

The general technical requirements are given in ISO 5743.

The carpenter's pincers illustrated in this International Standard are examples only and are not intended to affect the manufacturers' design.

2 Normative references

The following standards contain provisions which, through reference in this text, constitute provisions of this International Standard. At the time of publication, the editions indicated were valid. All standards are subject to revision, and parties to agreements based on this International Standard are encouraged to investigate the possibility of applying the most recent editions of the standards listed below. Members of IEC and ISO maintain registers of currently valid International Standards.

ISO 5743 : 1982, *Pliers and nippers — General technical requirements*.

ISO 5744 : 1988, *Pliers and nippers — Methods of test*.

3 Dimensions, hardness and test values

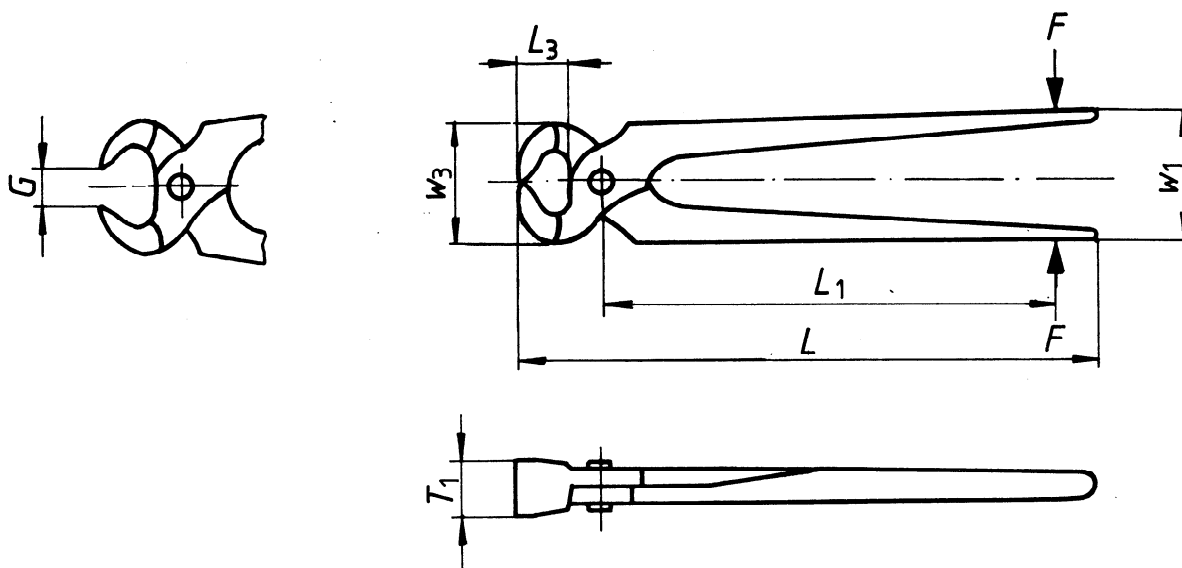

a) Type 1

iTeh STANDARD PREVIEW
(standards.iteh.ai)

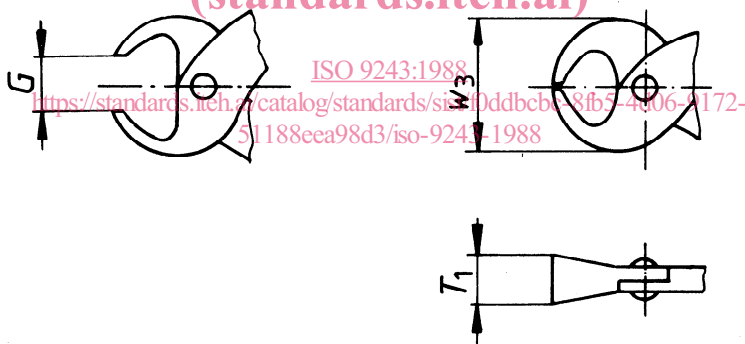

b) Type 2

Figure 1 — Carpenter's pincers

Table 1

L	L ₃ min.	w ₃ min.	Pincers		w ₁ ± 5	G min.	L ₁	Load test	
			type 1	type 2				Load F	Maximum permanent set s _{max} ¹⁾
			min.	max.					
mm	mm	mm	mm	mm	mm	mm	mm	N	mm
160 ± 8	11,2	32	16	14	45	12,5	106	710	1,2
180 ± 9	12,5	36	18	16	45	14	118	710	1,4
200 ± 10	14	40	20	18	45	16	132	800	1,6
224 ± 10	16	45	22	20	48	18	150	900	1,8
250 ± 10	18	50	25	22	50	20	170	1 000	2
280 ± 15	20	56	28	25	53	22	190	1 120	2,2

1) $s = w_1 - w_2$ (See ISO 5744.)

Carpenter's pincers shall have a minimum cutting edge hardness of 45 HRC.

After the load test, the permanent set s shall not exceed the value given in table 1. If the distance L_1 is not suitable for the load test, the following formula may be applied :

$$F' = \frac{F \times L_1}{L_1}$$

where

F' is the load which is not given in table 1;

F is the load given in table 1;

L_1 is the distance from the centre of the joint rivet to the point of application of the load given in table 1;

L_1' is the measured distance from the centre of the joint rivet to the point of application of the load.

iTeh STANDARD PREVIEW
(standards.iteh.ai)

ISO 9243:1988

<https://standards.iteh.ai/catalog/standards/sist/f0ddbcbc-8fb5-4d06-9172-51188eea98d3/iso-9243-1988>

iTeh STANDARD PREVIEW
(standards.iteh.ai)

This page intentionally left blank

ISO 9243:1988

<https://standards.iteh.ai/catalog/standards/sist/f0ddbcbc-8fb5-4d06-9172-51188eea98d3/iso-9243-1988>

iTeh STANDARD PREVIEW
(standards.iteh.ai)

This page intentionally left blank

ISO 9243:1988

<https://standards.iteh.ai/catalog/standards/sist/f0ddbcbc-8fb5-4d06-9172-51188eea98d3/iso-9243-1988>

iTeh STANDARD PREVIEW
(standards.iteh.ai)

ISO 9243:1988

<https://standards.iteh.ai/catalog/standards/sist/f0ddbcbc-8fb5-4d06-9172-51188eea98d3/iso-9243-1988>

UDC 621.881.4 : 694.1

Descriptors : tools, hand tools, pliers, specifications, dimensions.

Price based on 3 pages
