



Standard Test Method for Volatility of Liquefied Petroleum (LP) Gases¹

This standard is issued under the fixed designation D 1837; the number immediately following the designation indicates the year of original adoption or, in the case of revision, the year of last revision. A number in parentheses indicates the year of last reapproval. A superscript epsilon (ϵ) indicates an editorial change since the last revision or reapproval.

1. Scope

1.1 This test method is a measure of the relative purity of the various types of liquefied petroleum (LP) gases and helps to ensure suitable volatility performance. The test results, when properly related to vapor pressure and density of the product, can be used to indicate the presence of butane and heavier components in propane type LP-gas, and pentane and heavier components in propane-butane and butane type fuels. The presence of hydrocarbon compounds less volatile than those of which the LP-gas is primarily composed is indicated by an increase in the 95 % evaporated temperature.

1.2 When the type and concentration of higher boiling components is required, chromatographic analysis should be used.

1.3 The values stated in SI units are to be regarded as the standard. The values given in parentheses are for information only.

1.4 *This standard does not purport to address all of the safety concerns, if any, associated with its use. It is the responsibility of the user of this standard to establish appropriate safety and health practices and determine the applicability of regulatory limitations prior to use.*

2. Referenced Documents

2.1 ASTM Standards:

D 96 Test Methods for Water and Sediment in Crude Oil by Centrifuge Method (Field Procedure)²

D 1796 Test Method for Water and Sediment in Fuel Oils by the Centrifuge Method (Laboratory Procedure)²

E 1 Specification for ASTM Thermometers³

3. Summary of Test Method

3.1 Refrigerate the sample by means of a cooling coil and collect 100 mL of liquid in a weathering tube. Allow to evaporate (“weather”) at ambient pressure under specified conditions that approximate a single plate distillation. Correct the observed temperature, when 5 mL of liquid test portion remains, for barometric pressure and thermometer ice point error, and report as the 95 % evaporation temperature.

¹ This test method is under the jurisdiction of ASTM Committee D02 on Petroleum Products and Lubricants and is the direct responsibility of Subcommittee D02.H on Liquefied Petroleum Gas.

Current edition approved Jan. 10, 2001. Published February 2001. Originally published as D 1837 – 61 T. Last previous edition D 1837 – 94.

² *Annual Book of ASTM Standards*, Vol 05.01.

³ *Annual Book of ASTM Standards*, Vol 14.03.

4. Significance and Use

4.1 Volatility, expressed in terms of the 95 % evaporated temperature of the product, is a measure of the amount of least volatile components present in the product. Coupled with a vapor pressure limit, it serves to ensure essentially single-component products in the cases of commercial grades of propane and butane. When volatility is coupled with a vapor pressure limit which has been related to density, as in the case of the commercial PB-mixture, the combination serves to assure essentially two component mixtures for such fuels. When coupled with a proper vapor pressure limit, this measurement serves to assure that special-duty propane products will be composed chiefly of propane and propylene and that propane will be the major constituent.

5. Apparatus

5.1 *Weathering Tube*—A centrifuge tube, cone-shaped, conforming to the dimensions given in Fig. 1 and made of thoroughly annealed heat-resistant glass.⁴ The shape of the lower tip of the tube is especially important. The taper shall be uniform and the bottom shall be rounded as shown in Fig. 1. The tubes shall comply in wall thickness to ASTM centrifuge tube requirements (Note 1). The graduation tolerances are given in Table 1.

NOTE 1—Requirements for centrifuge tubes appear in Test Methods D 96 and D 1796.

5.2 *Tube Support*—Means shall be provided for supporting the weathering tube by its neck in a vertical position.

5.3 *Water Bath* (for use in tests on butane and propane-butane mixture types of liquefied petroleum gas only). A shallow container filled with clean water having a maintained temperature ranging from 15 to 21°C (60 to 70°F) and a depth of 38 mm (1½ in.).

5.4 *Thermometer*—ASTM Armored Weathering Test Thermometer having a range from –50 to 5°C (–58 to 41°F) and conforming to the requirements for Thermometer 99C–92 (99F–86) as prescribed in Specification E 1. Do not remove the armor from the thermometer.

5.5 *Sampling Precooling Equipment:*

5.5.1 *Cooling Vessel*—Any suitable wide-mouthed metal container or Dewar flask at least 64 mm (2½ in.) in inside diameter by 292 mm (11½ in.) deep.

⁴ Borosilicate glass has been found satisfactory for this purpose.

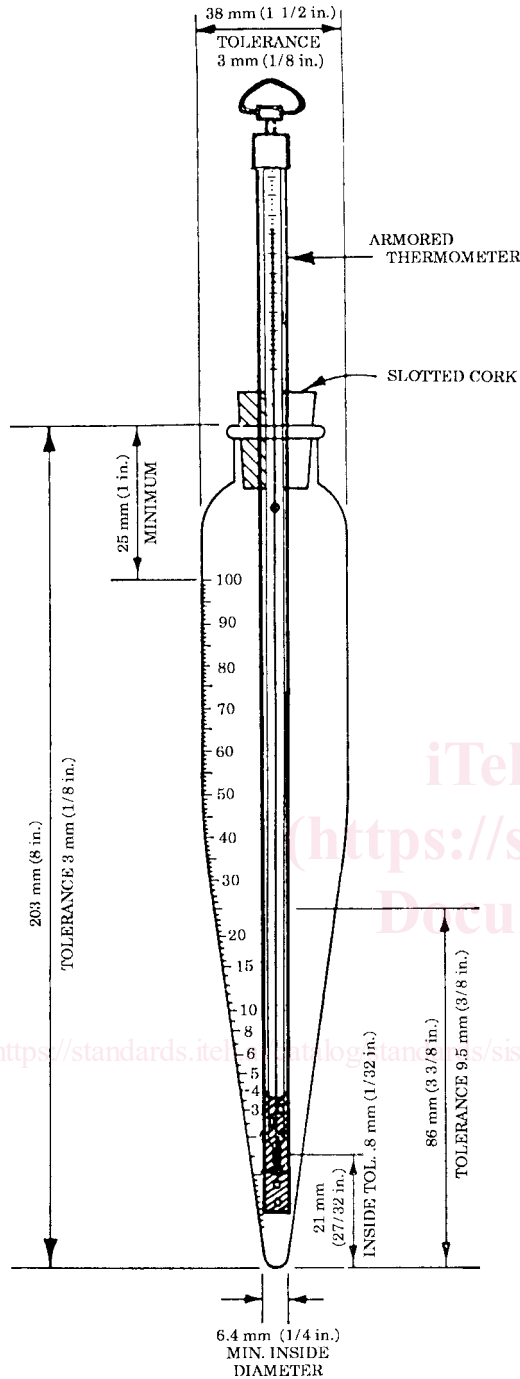

NOTE 1—For graduation tolerances see Table 1.
FIG. 1 Weathering Tube

5.5.2 *Cooling Coil*—Approximately 6 m (20 ft) of 4.8-mm ($\frac{3}{16}$ -in.) outside diameter soft copper tubing, wound around a hollow mandrel at least 54 mm ($\frac{2}{8}$ in.) in outside diameter, with adjacent turns touching. Run the lower end of the tube up through the center of the mandrel before winding so that the finished coil will fit snugly inside the cooling vessel. When assembled, the top of the coil shall be at least 25 mm (1 in.) below the top of the cooling vessel and the open ends of the coil shall not be more than 100 mm (4 in.) above. Connect the downstream end of the coil to a 3.2 mm ($\frac{1}{8}$ in.) needle valve

TABLE 1 Weathering Tube Graduation Tolerances

Range, mL	Scale Division, mL	Limit of Error, mL
0.0 to 0.1	0.05	0.02
0.1 to 0.3	0.05	0.03
0.3 to 0.5	0.05	0.05
0.5 to 1.0	0.1	0.05
1.0 to 3.0	0.1	0.1
3.0 to 5.0	0.5	0.2
5.0 to 25.0	1.0	0.5
25.0 to 100.0	1.0	1.0

having an outlet connection not more than 76 mm (3 in.) long (see Fig. 2).

5.5.3 *Precoolant*—This can be the liquefied petroleum gas from the same container from which a sample is to be taken. Other refrigerants having a boiling point lower than the initial boiling point of the sample can be used. Use a nonflammable precoolant if required.

6. Procedure

6.1 *Positioning the Thermometer*—Insert the armored thermometer as low as possible into the centrifuge tube and pipet in 5 mL \pm 0.05 mL of water. Observe and record the water level in the tube. Remove the water and clean and dry the centrifuge tube.

6.2 *Obtaining a Test Portion*—Fill the cooling vessel with the precoolant so as to cover the cooling coil. Attach the inlet of the cooling coil to the source from which the sample is to be

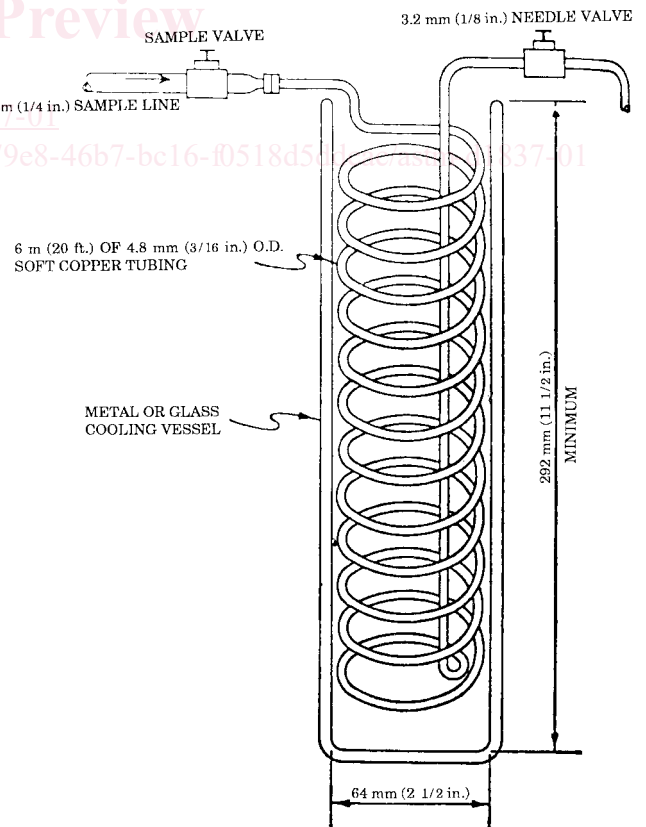

NOTE 1—The coils in the drawing are extended for clarity.
FIG. 2 Precooling Equipment