



## Standard Test Method for Flash Point by Tag Closed Tester<sup>1</sup>

This standard is issued under the fixed designation D 56; the number immediately following the designation indicates the year of original adoption or, in the case of revision, the year of last revision. A number in parentheses indicates the year of last reapproval. A superscript epsilon ( $\epsilon$ ) indicates an editorial change since the last revision or reapproval.

*This standard has been approved for use by agencies of the Department of Defense.*

*This test method has been adopted for use by government agencies to replace Method 1101 of Federal Test Method Standard No. 791b, and Method 4291 of Federal Test Method Standard No. 141A.*

### INTRODUCTION

To ensure an acceptable precision, this dynamic flash point test method employs a prescribed rate of temperature rise for the material under test. The rate of heating may not in all cases give the precision quoted in the test method because of the low thermal conductivity of certain materials. To improve the prediction of flammability, Test Method D 3941, which utilizes a slower heating rate, was developed. Test Method D 3941 provides conditions closer to equilibrium where the vapor above the liquid and the liquid are at about the same temperature. If a specification requires Test Method D 56, do not change to D 3941 or other test method without permission from the specifier.

### 1. Scope

1.1 This test method covers the determination of the flash point, by tag manual and automated closed testers, of liquids with a viscosity below  $5.5 \text{ mm}^2/\text{s}$  (cSt) at  $40^\circ\text{C}$  ( $104^\circ\text{F}$ ), or below  $9.5 \text{ mm}^2/\text{s}$  (cSt) at  $25^\circ\text{C}$  ( $77^\circ\text{F}$ ), and a flash point below  $93^\circ\text{C}$  ( $200^\circ\text{F}$ ).

1.1.1 For the closed-cup flash point of liquids with the following properties: a viscosity of  $5.5 \text{ mm}^2/\text{s}$  (cSt) or more at  $40^\circ\text{C}$  ( $104^\circ\text{F}$ ); a viscosity of  $9.5 \text{ mm}^2/\text{s}$  (cSt) or more at  $25^\circ\text{C}$  ( $77^\circ\text{F}$ ); a flash point of  $93^\circ\text{C}$  ( $200^\circ\text{F}$ ) or higher; a tendency to form a surface film under test conditions; or containing suspended solids, Test Method D 93 can be used.

1.1.2 For cut-back asphalts refer to Test Methods D 1310 and D 3143.

NOTE 1—The U.S. Department of Transportation (RSTA)<sup>2</sup> and U.S. Department of Labor (OSHA) have established that liquids with a flash point under  $37.8^\circ\text{C}$  ( $100^\circ\text{F}$ ) are flammable as determined by this test method for those liquids that have a viscosity less than  $5.5 \text{ mm}^2/\text{s}$  (cSt) at  $40^\circ\text{C}$  ( $104^\circ\text{F}$ ) or  $9.5 \text{ mm}^2/\text{s}$  (cSt) or less at  $25^\circ\text{C}$  ( $77^\circ\text{F}$ ), or do not contain suspended solids or do not have a tendency to form a surface film while under test. Other flash point classifications have been established by these departments for liquids using this test method.

1.2 This test method can be used to measure and describe

<sup>1</sup> This test method is under the joint jurisdiction of ASTM Committee D02 on Petroleum Products and Lubricants and is the direct responsibility of Subcommittee D02.08 on Volatility.

Current edition approved Aug. 10, 2000. Published October 2000. Originally published as D 56 – 18 T. Last previous edition D 56 – 98a.

<sup>2</sup> For information on United States Department of Transportation regulations, see Codes of United States Regulation 49 CFR Chapter 1 and for information on United States Department of Labor regulations, see Code of United States Regulation 29 CFR Chapter XVII. Each of these items are revised annually and may be procured from the Superintendent of Documents, Government Printing Office, Washington, DC 20402.

the properties of materials, products, or assemblies in response to heat and flame under controlled laboratory conditions and cannot be used to describe or appraise the fire hazard or fire risk of materials, products, or assemblies under actual fire conditions. However, results of this test method can be used as elements of fire risk assessment that takes into account all of the factors that are pertinent to an assessment of the fire hazard of a particular end use.

1.3 Related Standards are Test Methods D 93, D 1310, D 3828, D 3278, and D 3941.

1.4 The values stated in SI units are to be regarded as standard. The values in parentheses are for information only.

1.5 *This standard does not purport to address all of the safety concerns, if any, associated with its use. It is the responsibility of the user of this standard to establish appropriate safety and health practices and determine the applicability of regulatory limitations prior to use.* For specific hazard statements see 8.2 and 8.3 and refer to Material Safety Data Sheets.

### 2. Referenced Documents

#### 2.1 ASTM Standards:

D 93 Test Methods for Flash Point by Pensky-Martens Closed Cup Tester<sup>3</sup>

D 1310 Test Method for Flash Point and Fire Points of Liquids by Tag Open-Cup Apparatus<sup>4</sup>

D 3143 Test Method for Flash Point of Cutback Asphalt with Tag Open-Cup Apparatus<sup>5</sup>

<sup>3</sup> Annual Book of ASTM Standards, Vol 05.01.

<sup>4</sup> Annual Book of ASTM Standards, Vol 06.01.

<sup>5</sup> Annual Book of ASTM Standards, Vol 04.03.

D 3278 Test Methods for Flash Point of Liquids by Set-  
 aflash Closed-Cup Apparatus<sup>4</sup>

D 3828 Test Methods for Flash Point by Small Scale Closed  
 Tester<sup>6</sup>

D 3941 Test Method for Flash Point by the Equilibrium  
 Method with a Closed-Cup Apparatus<sup>4</sup>

D 4057 Practice for Manual Sampling for Petroleum and  
 Petroleum Products<sup>6</sup>

E 1 Specification for ASTM Thermometers<sup>7</sup>

E 502 Test Method for Selection and Use of ASTM Stan-  
 dards for the Determination of Flash Point of Chemicals by  
 Closed Cup Methods<sup>8</sup>

## 2.2 Federal Test Method Standards:<sup>9</sup>

Method 1101, Federal Test Method Standard No. 791b

Method 4291, Federal Test Method Standard No. 141A

## 2.3 ISO Standards:<sup>10</sup>

Guide 34 Quality Systems Guidelines for the Production of  
 Reference Materials

Guide 35 Certification of Reference Materials—General  
 and Statistical Principles

### 3. Terminology

#### 3.1 Definition:

3.1.1 *flash point*—the lowest temperature corrected to a  
 pressure of 101.3 kPa (760 mm Hg) at which application of an  
 ignition source causes the vapors of a specimen of the sample  
 to ignite under specified conditions of test.

3.1.1.1 *Discussion*—The specimen is deemed to have  
 flashed when a flame appears and instantaneously propagates  
 itself over the entire surface of the fluid.

3.1.1.2 *Discussion*—When the ignition source is a test  
 flame, the application of the test flame may cause a blue halo  
 or an enlarged flame prior to the actual flash point. This is not  
 a flash and should be ignored.

#### 3.2 Definitions of Terms Specific to This Standard:

3.2.1 *dynamic (non-equilibrium)*—in this type of flash point  
 apparatus, the condition of the vapor above the specimen and  
 the specimen are not at the same temperature at the time that  
 the ignition source is applied.

3.2.1.1 *Discussion*—This is primarily caused by the heating  
 of the specimen at the constant prescribed rate with the vapor  
 temperature lagging behind the specimen temperature. The  
 resultant flash point temperature is generally within the repro-  
 ducibility of the test method.

3.2.2 *equilibrium*—in that type of flash point apparatus or  
 test method, the vapor above the specimen and the specimen  
 are at the same temperature at the time the ignition source is  
 applied.

3.2.2.1 *Discussion*—This condition may not be fully  
 achieved in practice, since the temperature is not uniform  
 throughout the specimen and the test cover and shutter are  
 generally cooler.

<sup>6</sup> Annual Book of ASTM Standards, Vol 05.02.

<sup>7</sup> Annual Book of ASTM Standards, Vol 14.03.

<sup>8</sup> Annual Book of ASTM Standards, Vol 14.02.

<sup>9</sup> Available from Superintendent of Documents, U.S. Government Printing  
 Office, Washington, DC 20402.

<sup>10</sup> Available from American National Standards Institute, 11 W. 42nd St., 13th  
 Floor, New York, NY 10036.

### 4. Summary of Test Method

4.1 The specimen is placed in the cup of the tester and, with  
 the lid closed, heated at a slow constant rate. An ignition source  
 is directed into the cup at regular intervals. The flash point is  
 taken as the lowest temperature at which application of the  
 ignition source causes the vapor above the specimen to ignite.

### 5. Significance and Use

5.1 Flash point measures the tendency of the specimen to  
 form a flammable mixture with air under controlled laboratory  
 conditions. It is only one of a number of properties that shall be  
 considered in assessing the overall flammability hazard of a  
 material.

5.2 Flash point is used in shipping and safety regulations to  
 define flammable and combustible materials. One should  
 consult the particular regulation involved for precise defini-  
 tions of these classes.

5.3 Flash point can indicate the possible presence of highly  
 volatile and flammable materials in a relatively nonvolatile or  
 nonflammable material. For example, an abnormally low flash  
 point on a sample of kerosene can indicate gasoline contami-  
 nation.

### 6. Apparatus (Manual Instrument)

6.1 *Tag Closed Tester*—The apparatus is shown in Fig. 1  
 and described in detail in Annex A1.

6.2 *Shield*—A shield 460 mm (18 in.) square and 610 mm  
 (24 in.) high, open in front, is recommended.

6.3 *Thermometers*—For the test cup thermometer, use one  
 as prescribed in Table 1. For the bath thermometer, any  
 convenient type that has an adequately open scale covering the  
 required range may be used; it is often convenient to use the  
 same type of thermometer as used in the test cup.

NOTE 2—Whenever thermometers complying with ASTM require-  
 ments are not available, thermometers complying with the requirements  
 for The Institute of Petroleum thermometer IP 15C PM-Low can be used.

### 7. Sampling

7.1 Erroneously high flash points will be obtained when  
 precautions are not taken to avoid the loss of volatile material.  
 Containers should not be opened unnecessarily to prevent loss  
 of volatile material and possible introduction of moisture.  
 Transfers should not be made unless the sample temperature is  
 at least 10°C (18°F) below the expected flash point. When  
 possible, flash point shall be the first test performed on a  
 sample and the sample must be stored at low temperature.

7.2 Do not store samples in gas-permeable containers since  
 volatile materials may diffuse through the walls of the enclo-  
 sure. Samples in leaky containers are suspect and not a source  
 of valid results.

7.3 At least 50 mL of sample is required for each test. Refer  
 to sampling Practice D 4057.

### 8. Preparation of Apparatus (Manual)

8.1 Support the manual apparatus on a level steady surface,  
 such as a table. Unless tests are made in a draft-free room or  
 compartment, surround the tester on three sides by the shield  
 for protection from drafts. Tests are not to be made in a  
 laboratory draft hood or near ventilators.

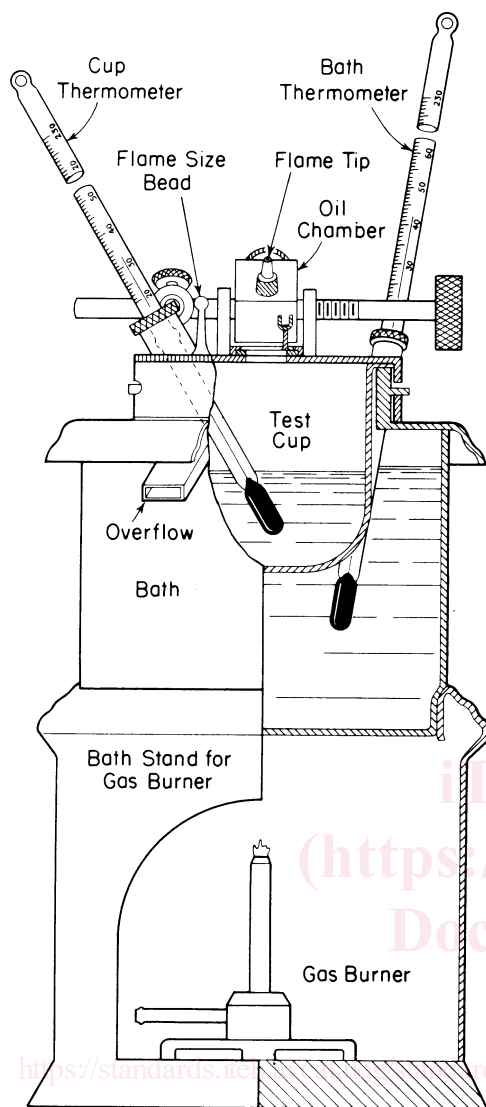

FIG. 1 Tag Closed Flash Tester (Manual)

TABLE 1 Thermometers

For tests	Below 4°C (40°F)	At 4 to 49°C (40 to 120°F)	Above 49°C (120°F)
Use ASTM Thermometer <sup>A</sup>	57C or (57F)	9C or (9F) 57C or (57F)	9C or (9F)

<sup>A</sup>Complete specifications for these thermometers are given in Specification E 1.

8.2 Natural gas and bottled gas flame and electric ignitors have been found acceptable for use as the ignition source. **Warning**—Gas pressure supplied to the apparatus must not be allowed to exceed 3 kPa (12 in.) of water pressure.

8.3 For flash points below 13°C (55°F) or above 60°C (140°F), use as a bath liquid a 1 + 1 mixture of water and ethylene glycol (see **Warning**—Ethylene Glycol—Poison. Harmful or fatal if swallowed. Vapor harmful. Avoid contact with skin.). For flash points between 13°C (55°F) and 60°C (140°F), either water or a water-glycol mixture can be used as bath liquid. The temperature of the liquid in the bath shall be at least 10°C (18°F) below the expected flash point at the time of introduction of the sample into the test cup. Do not cool bath liquid by direct contact with dry ice (solid carbon dioxide).

NOTE 3—Due to possible difficulty in maintaining the prescribed rate of temperature rise and due to the formation of ice on the lid, results by this test method for samples having flash points below 0°C (32°F) may be unreliable. Trouble due to ice formation on the slide can be minimized by carefully lubricating the slide shutter with high-vacuum silicone lubricant.

8.4 Verify the performance of the manual apparatus (or in 11.2.3, the automated apparatus) at least once per year by determining the flash point of a certified reference material (CRM), such as those listed in Annex A2, which is reasonably close to the expected temperature range of the samples to be tested. The material shall be tested according to the procedure of this test method and the observed flash point obtained in 9.5 shall be corrected for barometric pressure (see Section 13). The flash point obtained shall be within the limits stated in Table A2.1 for the identified CRM or within the limits calculated for an unlisted CRM (see Annex A2).

8.5 Once the performance of the apparatus has been verified, the flash point of secondary working standards (SWSs) can be determined along with their control limits. These secondary materials can then be utilized for more frequent performance checks (see Annex A2).

8.6 When the flash point obtained is not within the limits stated in 8.4 or 8.5, check the condition and operation of the apparatus to ensure conformity with the details listed in Annex A1, especially with regard to tightness of the lid (see A1.1.2), the action of the shutter, the position of the ignition source (see A1.1.2.3), and the angle and position of the temperature measuring device (see A1.1.2.4). After any adjustment, repeat the test in 8.4 using fresh test specimen, with special attention to the procedural details prescribed in the test method.

## 9. Procedure (Manual)

9.1 Using a graduated cylinder and taking care to avoid wetting the cup above the final liquid level, measure  $50 \pm 0.5$  mL of the sample into the cup, both the sample and graduated cylinder being precooled, when necessary, so that the specimen temperature at the time of measurement will be  $27 \pm 5^\circ\text{C}$  ( $80 \pm 10^\circ\text{F}$ ) or at least  $10^\circ\text{C}$  ( $18^\circ\text{F}$ ) below the expected flash point, whichever is lower. It is essential that the sample temperature be maintained at least  $10^\circ\text{C}$  ( $18^\circ\text{F}$ ) below the expected flash point during the transfers from the sample container to the cylinder and from the cylinder to the test cup. Destroy air bubbles on the surface of the specimens by use of knife point or other suitable device. Wipe the inside of the cover with a clean cloth or absorbent tissue paper; then attach the cover, with the thermometer in place, to the bath collar.

9.2 Light the test flame, when used, adjusting it to the size of the small bead on the cover. Operate the mechanism on the cover in such a manner as to introduce the ignition source into the vapor space of the cup, and immediately bring it up again. The time consumed for the full operation should be 1 s, allowing equal time periods for the introduction and return. Avoid any hesitation in the operation of depressing and raising the ignition source. When a flash is observed on the initial operation of the mechanism, discontinue the test and discard the result. In this case, a fresh sample shall be cooled an additional  $10^\circ\text{C}$  ( $18^\circ\text{F}$ ), below the original specimen installation temperature.

9.2.1 Exercise care when using a test flame, if the flame is

extinguished it cannot ignite the specimen and the gas entering the vapor space can influence the result. When the flame is prematurely extinguished the test shall be discontinued and any result discarded.

9.3 *Flash Points Below 60°C (140°F)*—When the flash point of the sample is known to be below 60°C (140°F), apply and adjust the heat so that the temperature of the portion will rise at a rate of 1°C (2°F)/min ± 6 s. When the temperature of the specimen in the test cup is 5°C (10°F) below its expected flash point, apply the ignition source in the manner just described in 9.2 and repeat the application of the ignition source after each 0.5°C (1°F) rise in temperature of the specimen.

9.4 *Flash Points at 60°C (140°F) or Above*—If the flash point of the sample is known to be 60°C (140°F) or higher, apply and adjust the heat so that the temperature of the specimen will rise at a rate of 3°C (5°F)/min ± 6 s. When the temperature of the specimen in the test cup is 5°C (10°F) below its expected flash point, apply the ignition source in the manner just described in 9.2 and repeat the application of the ignition source each 1°C (2°F) rise in temperature of the specimen.

9.5 When the application of the ignition source causes a distinct flash in the interior of the cup, as defined in 3.1.1, observe and record the temperature of the specimen as the flash point. Do not confuse the true flash with the bluish halo that sometimes surrounds the ignition source during applications immediately preceding the actual flash. **Warning**—For certain mixtures containing halogenated hydrocarbons, such as, methylene chloride or trichloroethylene, no distinct flash, as defined, is observed. Instead a significant enlargement of the test flame (not halo effect) and change in color of the test flame from blue to yellowish-orange occurs. Continued heating and testing of these samples above ambient temperature can result in significant burning of vapors outside the test cup, and can be a potential fire hazard. See Appendix X1 and Appendix X2 for more information.

9.6 Discontinue the test and remove the source of heat. Lift the lid and wipe the thermometer bulb. Remove the test cup, empty, and wipe dry.

9.7 If, at any time between the first introduction of the ignition source and the observation of the flash point, the rise in temperature of the specimen is not within the specified rate, discontinue the test, discard the result and repeat the test, adjusting the source of heat to secure the proper rate of temperature rise, or using a modified “expected flash point,” or both, as required.

9.8 Never make a repeat test on the same specimen of sample; always take fresh specimen of sample for each test.

## 10. Apparatus (Automated Instrument)

10.1 An automated flash point instrument is used that is capable of performing the test in accordance with Section 9, Procedure (Manual) of the test method. The apparatus can use a gas test flame or electric ignitor. The dimensions for the test cup and test cover are shown in Fig. A1.1 and Fig. A1.2.

10.2 Samples with low flash point may require a source of cooling for the heating area.

## 11. Preparation of Apparatus (Automated Instrument)

11.1 Support the automated apparatus on a level, steady surface, such as a table. Unless tests are made in a draft-free compartment, it is a good practice, but not required, to surround the tester with a shield to prevent draft.

11.2 The user of the automatic instrument must be sure that all of the manufacturer’s instructions for calibrating, checking, and operating the equipment are followed.

11.2.1 Adjust the detection system per manufacturer’s instructions.

11.2.2 Calibrate the temperature measuring device per manufacturer’s instructions.

11.2.3 Verify the performance of the automated apparatus at least once per year by determining the flash point of a certified reference material (CRM) such as those listed in Annex A2, which is reasonably close to the expected temperature range of the samples to be tested. The material shall be tested according to the procedure of this test method and the observed flash point obtained in 9.5 shall be corrected for barometric pressure (see Section 13). The flash point obtained shall be within the limits stated in Table A2.1 for the identified CRM or within the limits calculated for an unlisted CRM (see Annex A2).

11.2.4 Once the performance of the apparatus has been verified, the flash point of secondary working standards (SWSs) can be determined along with their control limits. These secondary materials can then be utilized for more frequent performance checks (see Annex A2).

11.2.5 When the flash point obtained is not within the limits stated in 11.2.3 or 11.2.4, check the condition and operation of the apparatus to ensure conformity with the details listed in Annex A1, especially with regard to tightness of the lid (see A1.1.2), the action of the shutter, the position of the ignition source (see A1.1.2.3), and the angle and position of the temperature measuring device (see A1.1.2.4). After any adjustment, repeat the test in 11.2.3 using fresh test specimen, with special attention to the procedural details prescribed in the test method.

## 12. Procedure (Automated)

12.1 Adjust the external cooling system, if required, to a temperature necessary to cool the heating area 10°C below the expected flash point.

12.2 Place the test cup in position in the instrument.

12.3 When using a gas test flame, light the pilot flame and the test flame and adjust the test flame to 4 mm ( $\frac{5}{32}$  in.) in diameter. If the instrument is equipped with an electrical ignition device, adjust according to the manufacturer’s instructions.

12.4 Enter the Expected Flash Point; this will allow the heating area to be cooled to the required minimum starting temperature.

NOTE 4—To avoid an abnormal heating rate when the specimen is at a low temperature, it is recommended to precool the test cup and cover. This may be accomplished by placing the assembly into position in the instrument while it is cooling to 10°C (18°F) below the programmed Expected Flash Point.

NOTE 5—Flash Point results determined in an “unknown Expected Flash Point mode” should be considered approximate. This value can be used as the Expected Flash Point when a fresh specimen is tested in the

standard mode of operation.

12.5 Using a graduated cylinder and taking care to avoid wetting the cup above the final liquid level, measure  $50 \pm 0.5$  mL of the sample into the cup, both the sample and the graduated cylinder being precooled, when necessary, so that the specimen temperature at the time of the measurement is  $27 \pm 5^\circ\text{C}$  ( $80 \pm 10^\circ\text{F}$ ) or at least  $10^\circ\text{C}$  ( $18^\circ\text{F}$ ) below the expected flash point, whichever is lower. It is essential that the sample temperature be maintained at least  $10^\circ\text{C}$  ( $18^\circ\text{F}$ ) below the expected flash point during the transfers from the sample container to the cylinder and from the cylinder to the test cup. Destroy air bubbles on the surface of the specimen by use of knife point or other suitable device. Wipe the inside of the cover with a clean cloth or absorbent tissue paper; then attach the cover, with the temperature measuring device in place, to the bath collar. Connect the shutter and ignition source activator, if so equipped, into the lid housing. Readjust the size of the test flame or the setting of the electrical ignition device. Test the ignition source dipping action, if so equipped, and observe if the apparatus functions correctly. Press the start key. If a flash is observed upon initial operation, discontinue the test and discard the result. In this case a fresh specimen shall be cooled to an additional  $10^\circ\text{C}$  ( $18^\circ\text{F}$ ) below the original specimen installation temperature.

NOTE 6—Care should be taken when cleaning and positioning the lid assembly so as not to damage or dislocate the flash detection system or temperature measuring device. See manufacturer's instructions for proper care and maintenance.

12.6 The apparatus shall automatically control the test procedure as described in this test method. When the flash point is detected, the apparatus will record the temperature and automatically discontinue the test. If a flash is detected on the first application, the test should be discontinued, the result shall be discarded and the test repeated with a fresh specimen. **Warning**—For certain mixtures containing halogenated hydrocarbons, such as, methylene chloride or trichloroethylene, no distinct flash, as defined, is observed. Instead a significant enlargement of the test flame (not halo effect) and change in color of the test flame from blue to yellowish-orange occurs. Continued heating and testing of these samples above ambient temperature can result in significant burning of vapors outside the test cup, and can be a potential fire hazard. See Appendix X1 and Appendix X2 for more information.

12.7 When the apparatus has cooled down to a safe handling temperature (less than  $55^\circ\text{C}$  ( $130^\circ\text{F}$ )) remove the cover and the test cup and clean the apparatus as recommended by the manufacturer.

### 13. Report

13.1 Correction for barometric pressure. Observe and record the ambient barometric pressure at the time and place of the test. When the pressure differs from 101.3 kPa (760 mm Hg), correct the flash point as follows:

- (1) Corrected flash point =  $C + 0.25(101.3 - p)$
- (2) Corrected flash point =  $F + 0.06(760 - P)$
- (3) Corrected flash point =  $C + 0.033(760 - P)$  (1)

where:

- $C$  = observed flash point,  $^\circ\text{C}$ ,  
 $F$  = observed flash point,  $^\circ\text{F}$ ,  
 $p$  = ambient barometric pressure, kPa, and  
 $P$  = ambient barometric pressure, mm Hg.

13.2 The barometric pressure used in this calculation shall be the ambient pressure for the laboratory at the time of test. Many aneroid barometers, such as those used at weather stations and airports, are precorrected to give sea level readings; these shall not be used.

13.3 Report the corrected flash point to the nearest  $0.5^\circ\text{C}$  (or  $1^\circ\text{F}$ ).

### 14. Precision and Bias

14.1 *Precision*—The following criteria shall be used for judging the acceptability of results (95 % probability):

14.1.1 *Repeatability*—The difference between successive test results, obtained by the same operator with the same apparatus under constant operating conditions on identical test material, would in the long run, in the normal and correct operation of the test method, exceed the following values only in one case in twenty:

Flash Point, $^\circ\text{C}$ ( $^\circ\text{F}$ )	Repeatability, $^\circ\text{C}$ ( $^\circ\text{F}$ )
Below $60^\circ\text{C}$ ( $140^\circ\text{F}$ )	$1.2^\circ\text{C}$ ( $2.0^\circ\text{F}$ )
At and Above $60^\circ\text{C}$ ( $138.2^\circ\text{F}$ )	$1.6^\circ\text{C}$ ( $3.0^\circ\text{F}$ )

14.1.2 *Reproducibility*—The difference between two single and independent results, obtained by different operators working in different laboratories on identical test material, would in the long run, in the normal and correct operation of the test method, exceed the following values only in one case in twenty:

Flash Point, $^\circ\text{C}$ ( $^\circ\text{F}$ )	Reproducibility, $^\circ\text{C}$ ( $^\circ\text{F}$ )
Below $60^\circ\text{C}$ ( $140^\circ\text{F}$ )	$4.3^\circ\text{C}$ ( $8^\circ\text{F}$ )
At and Above $60^\circ\text{C}$ ( $138.2^\circ\text{F}$ )	$5.8^\circ\text{C}$ ( $10^\circ\text{F}$ )

14.2 *Bias*—The procedure in Test Method D 56 for measuring flash point has no bias since the tag flash point can be defined only in terms of this test method. The current inter-laboratory tests confirm that there is no relative bias between manual and automated procedures. In any case of dispute the flash point as determined by the manual procedure shall be considered the referee test.

NOTE 7—Mixtures such as, but not limited to, those that are chlorinated or include water may cause significant differences in the results obtained by manual and automatic instruments. For these mixtures, the precision statement may not apply.

NOTE 8—The precision data were developed in a 1991 cooperative test program<sup>11</sup> using eight (8) samples. Twelve (12) laboratories participated with the manual apparatus and seventeen (17) laboratories participated with the automatic equipment. Information on the type of samples and their average flashpoints are in the research report available at ASTM Headquarters.

### 15. Keywords

15.1 combustible; fire risk; flammable; flash point; tag closed cup

<sup>11</sup> Data is available from ASTM Headquarters. Request RR:S15-1007.

ANNEXES

(Mandatory Information)

A1. APPARATUS

A1.1 The Tag closed tester shall consist of the test cup, lid with ignition source, and liquid bath conforming to the following requirements:

A1.1.1 Test Cup, of brass or other nonrusting metal of equivalent heat conductivity, conforming to dimensional requirements prescribed in Fig. A1.1. It shall weigh  $68 \pm 1$  g.

A1.1.2 Lid:

A1.1.2.1 The lid comprises a circle of nonrusting metal with a rim projecting downward about 15.9 mm ( $\frac{5}{8}$  in.), a slide shutter, a device which simultaneously opens the shutter and depresses the ignition source, and a slanting collar in which the cup-thermometer ferrule is inserted. Fig. A1.2 gives a diagram of the upper surface of the lid, showing dimensions and positions of the three holes opened and closed by the shutter, and the size and position of the opening for the cup thermometer.

A1.1.2.2 The rim shall fit the collar of the liquid bath with a clearance not exceeding 0.4 mm (0.002 in.) and shall be slotted in such a manner as to press the lid firmly down on the top of the cup when the latter is in place in the bath. When this requirement is not met, the vertical position of the cup in the bath shall be suitably adjusted, as by placing a thin ring of metal under the flange of the cup.

A1.1.2.3 The shutter shall be of such size and shape that it covers the three openings in the lid when in the closed position and uncovers them completely when in the open position. The nozzle of the flame-exposure device, when used, shall conform to the dimensions given in Table A1.1. The ignition source device shall be designed and constructed so that opening the shutter depresses the tip to a point approximately 2 mm (0.08 in.) to the right of the horizontal center of the middle opening of the lid (refer to lower part of Fig. A1.3). This will bring the ignition source to the approximate center of the opening. The plane of the underside of the lid shall be between the top and bottom of the tip of the ignition source when the latter is fully depressed.

A1.1.2.4 The collar for the cup-thermometer ferrule shall be set at an angle that permits placement of the thermometer with

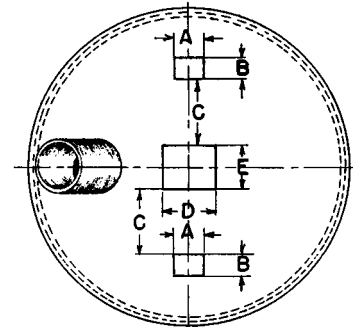

- A — 7.15 mm
- B — 4.78 mm
- C — 15.10 mm
- D — 11.92 mm
- E — 10.32 mm

Note: All dimensions  $\pm 0.13$  mm unless otherwise shown.

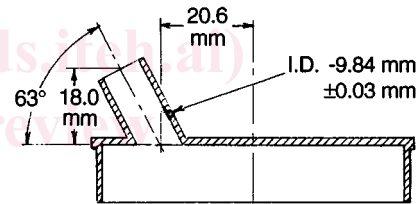

ASTM D56-00  
121b237-6475-492e-a5d/astm-d56-00

Inch-Pound Equivalents			
mm	in.	mm	in.
0.03	0.001	10.32	0.406
0.13	0.005	11.92	0.469
4.78	0.188	15.10	0.594
7.15	0.281	18.0	0.71
9.84	0.387	20.6	0.81

NOTE 1—Dimensions relating to the size and position of the thermometer collar are recommended but not mandatory.

FIG. A1.2 Top of Lid Showing Position and Dimensions of Openings

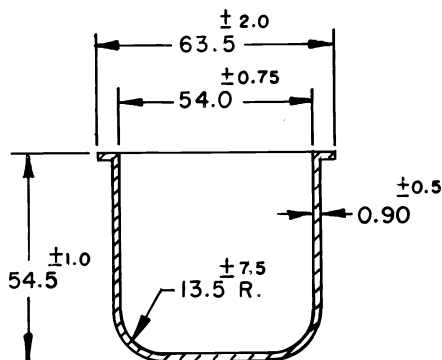

FIG. A1.1 Specimen Cup