



Designation: D 524 – 00

An American National Standard
British Standard 4451



Designation: 14/94

Standard Test Method for Ramsbottom Carbon Residue of Petroleum Products¹

This standard is issued under the fixed designation D 524; the number immediately following the designation indicates the year of original adoption or, in the case of revision, the year of last revision. A number in parentheses indicates the year of last reappraisal. A superscript epsilon (ϵ) indicates an editorial change since the last revision or reappraisal.

This standard has been approved for use by agencies of the Department of Defense.

This test method has been adopted for use by government agencies to replace Method 5002 of Federal Test Method Standard No. 791b.

1. Scope

1.1 This test method covers the determination of the amount of carbon residue (Note 1) left after evaporation and pyrolysis of an oil, and is intended to provide some indication of relative coke-forming propensity. This test method is generally applicable to relatively nonvolatile petroleum products which partially decompose on distillation at atmospheric pressure. Petroleum products containing ash-forming constituents as determined by Test Method D 482, will have an erroneously high carbon residue, depending upon the amount of ash formed (Note 2 and Note 3).

NOTE 1—The term *carbon residue* is used throughout this test method to designate the carbonaceous residue formed during evaporation and pyrolysis of a petroleum product. The residue is not composed entirely of carbon, but is a coke which can be further changed by pyrolysis. The term *carbon residue* is continued in this test method only in deference to its wide common usage.

NOTE 2—Values obtained by this test method are not numerically the same as those obtained by Test Method D 189, or Test Method D 4530. Approximate correlations have been derived (see Fig. X2.1) but need not apply to all materials which can be tested because the carbon residue test is applicable to a wide variety of petroleum products. The Ramsbottom Carbon Residue test method is limited to those samples that are mobile below 90°C.

NOTE 3—In diesel fuel, the presence of alkyl nitrates such as amyl nitrate, hexyl nitrate, or octyl nitrate, causes a higher carbon residue value than observed in untreated fuel, which can lead to erroneous conclusions as to the coke-forming propensity of the fuel. The presence of alkyl nitrate in the fuel can be detected by Test Method D 4046.

1.2 *This standard does not purport to address all of the safety concerns, if any, associated with its use. It is the responsibility of the user of this standard to establish appropriate safety and health practices and determine the applicability of regulatory limitations prior to use.*

¹ This test method is under the jurisdiction of ASTM Committee D-2 on Petroleum Products and Lubricants and is the direct responsibility of Subcommittee D02.06 on Analysis of Lubricants.

Current edition approved Apr. 10, 2000. Published June 2000. Originally published as D 524 – 39 T. Last previous edition D 524 – 97.

In the IP, this test method is under the jurisdiction of the Standardization Committee.

2. Referenced Documents

2.1 ASTM Standards:

- D 189 Test Method for Conradson Carbon Residue of Petroleum Products²
- D 482 Test Method for Ash from Petroleum Products²
- D 4046 Test Method for Alkyl Nitrate in Diesel Fuels by Spectrophotometry³
- D 4057 Practice for Manual Sampling of Petroleum and Petroleum Products³
- D 4175 Terminology Relating to Petroleum, Petroleum Products, and Lubricants³
- D 4177 Practice for Automatic Sampling of Petroleum and Petroleum Products³
- D 4530 Test Method for Determination of Carbon Residue (Micro Method)³
- E 1 Specification for ASTM Thermometers⁴
- E 133 Specification for Distillation Equipment⁵

3. Terminology

3.1 Definitions:

3.1.1 *carbon residue, n*—the residue formed by evaporation and thermal degradation of a carbon containing material.

D 4175

3.1.1.1 *Discussion*—The residue is not composed entirely of carbon but is a coke that can be further changed by carbon pyrolysis. The term carbon residue is retained in deference to its wide common usage.

4. Summary of Test Method

4.1 The sample, after being weighed into a special glass bulb having a capillary opening, is placed in a metal furnace maintained at approximately 550°C. The sample is thus quickly heated to the point at which all volatile matter is evaporated out of the bulb with or without decomposition while the heavier residue remaining in the bulb undergoes

² *Annual Book of ASTM Standards*, Vol 05.01.

³ *Annual Book of ASTM Standards*, Vol 05.02.

⁴ *Annual Book of ASTM Standards*, Vol 14.03.

⁵ *Annual Book of ASTM Standards*, Vol 14.02.

cracking and coking reactions. In the latter portion of the heating period, the coke or carbon residue is subject to further slow decomposition or slight oxidation due to the possibility of breathing air into the bulb. After a specified heating period, the bulb is removed from the bath, cooled in a desiccator, and again weighed. The residue remaining is calculated as a percentage of the original sample, and reported as Ramsbottom carbon residue.

4.2 Provision is made for determining the proper operating characteristics of the furnace with a control bulb containing a thermocouple, which must give a specified time-temperature relationship.

5. Significance and Use

5.1 The carbon residue value of burner fuel serves as a rough approximation of the tendency of the fuel to form deposits in vaporizing pot-type and sleeve-type burners. Similarly, provided alkyl nitrates are absent (or if present, provided the test is performed on the base fuel without additive) the carbon residue of diesel fuel correlates approximately with combustion chamber deposits.

5.2 The carbon residue value of motor oil, while at one time regarded as indicative of the amount of carbonaceous deposits a motor oil would form in the combustion chamber of an engine, is now considered to be of doubtful significance due to the presence of additives in many oils. For example, an ash-forming detergent additive can increase the carbon residue value of an oil yet will generally reduce its tendency to form deposits.

5.3 The carbon residue value of gas oil is useful as a guide in the manufacture of gas from gas oil, while carbon residue values of crude oil residuums, cylinder and bright stocks, are useful in the manufacture of lubricants.

6. Apparatus

6.1 *Glass Coking Bulb*, of heat-resistant glass conforming to the dimensions and tolerances shown in Fig. 1. Prior to use, check the diameter of the capillary to see that the opening is greater than 1.5 and not more than 2.0 mm. Pass a 1.5-mm diameter drill rod through the capillary and into the bulb;

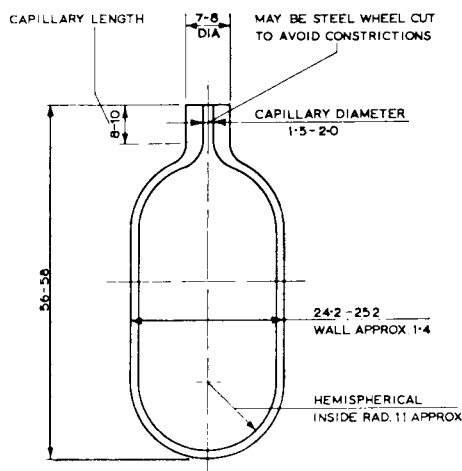

NOTE 1—All dimensions are in millimetres.

FIG. 1 Glass Coking Bulb

attempt to pass a 2.0-mm diameter drill rod through the capillary. Reject bulbs that do not permit the insertion of the smaller rod and those whose capillaries are larger than the larger rod.

6.2 *Control Bulb*, stainless steel, containing a thermocouple and conforming to the dimensions and tolerances shown in Fig. 2, for use in determining compliance of furnace characteristics with the performance requirements (Section 7). The control bulb shall be provided with a dull finish, as specified in Fig. 2, and must not be polished thereafter. A polished bulb has different heating characteristics from one with a dull finish. A suitable thermocouple pyrometer for observing true temperature within $\pm 1^\circ\text{C}$ is also required.

6.3 *Sample Charging Syringe*, 5 or 10-mL glass hypodermic (Note 4), fitted with a No. 17 needle (1.5 mm in outside diameter) or No. 0 serum needle (1.45 to 1.47 mm in outside diameter) for transfer of the sample to the glass coking bulb.

NOTE 4—A syringe having a needle that fits on the ground-glass tip of the syringe is not recommended, as it may be blown off when pressure is applied to the syringe plunger. The Luer-Lok type syringes are more satisfactory, as the needle locks on the bottom of the syringe barrel, and cannot be blown off by pressure.

6.4 *Metal Coking Furnace* of solid metal, having coking bulb wells 25.45 ± 0.1 mm in internal diameter and 76 mm deep to the center of the well bottom, with suitable arrangements for heating to a uniform temperature of 550°C . The bottom of the well shall be hemispherical to accommodate the bottom of the glass coking bulb. Do not cast or otherwise form the furnace with unnecessary voids which will impede heat transfer. If a molten metal furnace is used, provide it with a suitable number of bulb wells, the internal dimensions of which correspond to the internal dimensions of holes in the solid metal furnace. The bulb wells shall be immersed in the molten metal to leave not more than 3 mm of the bulb well exposed above the molten metal at operating temperatures.

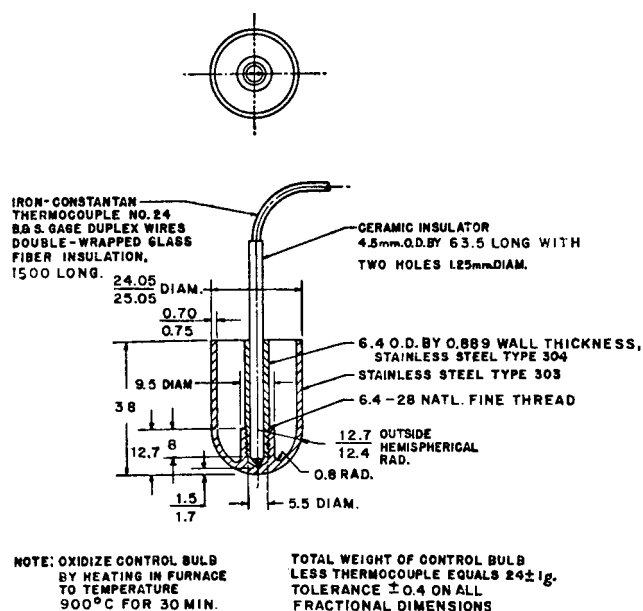

NOTE: OXIDIZE CONTROL BULB BY HEATING IN FURNACE TO TEMPERATURE 900°C FOR 30 MIN.

TOTAL WEIGHT OF CONTROL BULB LESS THERMOCOUPLE EQUALS $24 \pm 1\text{g}$. TOLERANCE ± 0.4 ON ALL FRACTIONAL DIMENSIONS

NOTE 1—All dimensions are in millimetres.

FIG. 2 Control Bulb

NOTE 5—Ramsbottom coke furnaces now in use can have dimensional differences from those given in 6.4; however, it is essential that new furnaces obtained after the adoption of this test method conform to the requirements outlined in 6.4. A description of one type of furnace which has been found to be satisfactory is given in Appendix X1.

6.5 *Temperature-Measuring Devices*— A removable iron-constantan thermocouple with a sensitive pyrometer, or other suitable temperature-indicating device, located centrally near the bottom portion of the furnace and arranged to measure the temperature of the furnace so that the performance tests specified in Section 7 can be obtained. It is desirable to protect the temperature-indicating device with a quartz or thin metal sheath when a molten bath is used.

NOTE 6—It is good practice to calibrate the thermocouple or other temperature-measuring device against a standard thermocouple or reference standards about once a week, when the furnace is in constant use, the actual frequency depending on experience.

7. Checking Performance of Apparatus

7.1 Periodically check the performance of the furnace and temperature-measuring devices as described in 7.1.1, 7.1.2, and 7.1.3 to make certain that as used they conform to the requirements of the method. Consider the furnace as having standard performance, and use it with any degree of loading, when the operating requirements described for each coking bulb well are met, while the bath is fully loaded as well as singly loaded. Use only a furnace that has successfully passed the performance or control tests given in this section.

7.1.1 *Thermocouple*—At least once every 50 h of use of the control bulb, calibrate the thermocouple in the control bulb against a standard thermocouple.

NOTE 7—In use at the high temperature of the test, iron-constantan thermocouples oxidize and their calibration curves change.

7.1.2 *Fully Loaded Furnace*—When the furnace temperature is within a previously chosen 2°C temperature range (which range is to be used thereafter with that particular furnace for both standardization and routine operation) and within the general range 550 ± 5°C, insert the control bulb in one well and, within 15 s, insert in each of the other wells a glass coking bulb containing 4 ± 0.1 g of a viscous neutral petroleum lubricating oil with a viscosity within the SAE 30 range or 60 to 100 mm²/s (cSt) at 40°C. With a suitably accurate potentiometer or millivoltmeter (sensitive to 1°C or less), observe the temperature rise in the control bulb at 1-min intervals for 20 min. If the temperature in the control bulb reaches 547°C in not less than 4 and not more than 6 min from the instant of its insertion in the furnace, and remains within the range 550 ± 3°C for the remaining portion of the 20-min test, consider that particular coking bulb well suitable for use as a *standard performance well* when the furnace is used fully loaded. Inspect each well in similar fashion with the furnace fully loaded each time.

7.1.3 *Singly Loaded Furnace*—When the furnace temperature is within a previously chosen 2°C temperature range (which range is to be used thereafter with that particular furnace for both standardization and routine operation) and within the general range 550 ± 5°C, insert the control bulb in one well, with the remaining wells unoccupied. With a suitably accurate potentiometer or millivoltmeter (sensitive to 1°C or

less), observe the temperature rise in the control bulb at 1-min intervals for 20 min. If the temperature in the control bulb reaches 547°C in not less than 4 and not more than 6 min from the instant of its insertion in the furnace, and remains within the range 550 ± 3°C for the remaining portion of the 20-min test, consider that particular coking bulb well suitable for use as a *standard performance well* when only a single test is made. Inspect each well in similar fashion with the furnace singly loaded each time.

NOTE 8—It is possible that not all of the wells in old furnaces will meet the requirements when fully loaded and singly loaded; and, when this is the case, inspect each well for any degree of furnace loading which may be used. For example, when not more than three wells of a six-well furnace can be used at any one time, the three wells to be used should be chosen from the performance data obtained with fully loaded and singly loaded furnaces. Then each of the three wells should be inspected for triple loading, two of the wells for double loading, and one for single loading. Use the wells tested and no others in applying the test procedure.

NOTE 9—In sampling oils containing sediment (for example, used oils), it is important to make the transfer of sample in the shortest possible time to avoid segregation of the sediment. Samples containing sediment which settles quickly after stirring can be placed in the coking bulbs more expeditiously by using an arrangement such as that shown in Fig. 3. This sampling device consists of a three-way 2-mm stopcock to which have been fused two lengths of capillary tubing (1.5 mm in inside diameter). Connect the third leg of the stopcock by means of pressure tubing to a vacuum line. Secure the glass coking bulb to the short arm of capillary tubing by a 25-mm length of rubber hose, taking care that the capillary of the glass bulb is butted up against the capillary tubing. Immerse the long end of the capillary tubing in the sample. After evacuating the coking bulb,

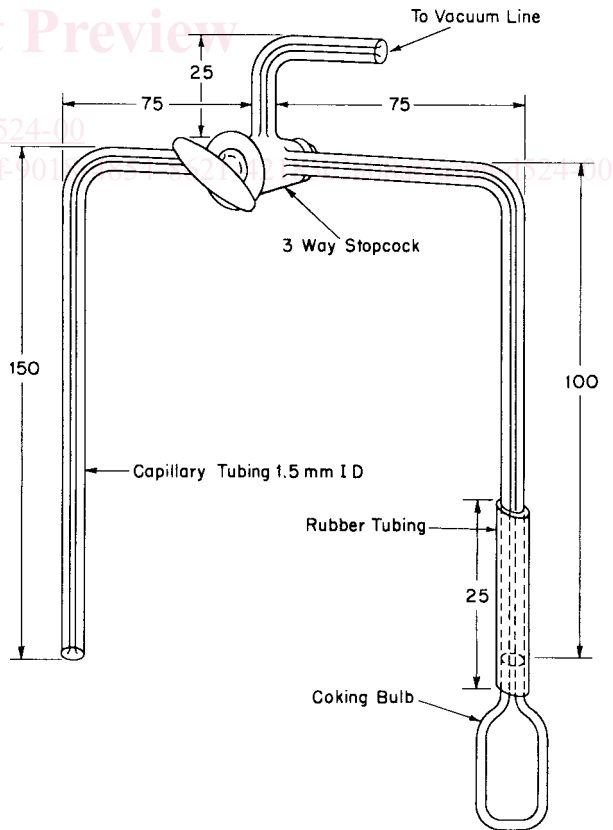

NOTE 1—All dimensions are in millimetres (1 in. = 25 mm).

FIG. 3 Sampling Device

manipulate the stopcock to cause the stirred sample to flow freely into the bulb through the two lengths of capillary tubing. It is necessary to use tubing with the same size capillary as that in the neck of the coking bulb to prevent accumulation of any sediment during transfer.

8. Sampling

8.1 For sampling techniques see Practice D 4057 or Practice D 4177.

9. Procedure

9.1 Place a new glass coking bulb (Note 11) in the coking furnace at 550°C for about 20 min to decompose any foreign organic matter and to remove water. Place in a closed desiccator over CaCl₂ for 20 to 30 min and then weigh to the nearest 0.1 mg.

NOTE 10—Do not re-use a glass coking bulb, as unpredictable results are sometimes obtained in such cases. For routine testing, new bulbs can be used without pre-ignition provided they are visibly free from particles or other contamination. Such bulbs, at least, should be heated in an oven to 150°C, placed in a desiccator, and then weighed.

NOTE 11—On making a test, it is important to adhere rigorously to the temperature conditions chosen for Checking Performance of Apparatus (Section 7); for example, if the bath was at a temperature of 553 ± 1°C when inserting the control bulb, then it is necessary to use similar temperature conditions in the coking test. When maintained in normal operation, the temperature of an electrically heated furnace with automatic controls will generally fluctuate within a specific temperature range. Therefore, when making a coking test, it is generally important that the test bulbs be inserted when the furnace is at the same temperature or at the same position in the temperature cycle as it was when the inspection test was started, unless it has been proven that the temperature variations are inappreciable.

9.2 Shake thoroughly the sample to be tested, first heating to 50° ± 10°C for 0.5 h when necessary to reduce its viscosity. Immediately following the heating and shaking, strain the sample through a 100-mesh wire screen. By means of a hypodermic syringe or the device shown in Fig. 3 introduce into the coking bulb an amount of sample as indicated in Table 1. Make sure that no oil remains on the exterior surface or on the inside of the neck of the bulb. Reweigh the bulb and contents to the nearest milligram. If the sample foams or spatters, repeat the test using the next smaller sample size listed in Table 1. In reporting the results, include the size when such small samples are used. If difficulty is encountered in loading very viscous or asphaltic samples of any size into the glass coking bulb, the apparatus shown in Fig. X1.2 can be used.

9.3 Place the coking bulb in a *standard performance well* with the furnace at the checking temperature (Note 11), and allow to remain for 20 ± 2 min. Remove the bulb with metal tongs, the tips of which have just been heated. Duplicate the furnace and bulb conditions used when standardizing that bulb well (Section 7 and Note 8). If there is appreciable loss of oil from frothing, discard the test and repeat the determination using a smaller sample (Note 12).

NOTE 12—Frothing can be due to water which can be removed by heating gently in a vacuum and sweeping out the vapor with nitrogen prior to filling the bulb.

9.4 After removal, cool the bulb in a desiccator under the same conditions (including time for weighing) used before filling the bulb (9.2). When removing the bulb from the desiccator, examine it to make sure there are no foreign particles adhering to the bulb; if any are found, as black particles sometimes are on the capillary neck, brush them off with a piece of sized paper or camels' hair brush. Weigh to the nearest 0.1 mg. Discard the used glass coking bulb.

NOTE 13—In studies of oil characteristics, useful information can often be gleaned from a simple visual examination of the coking bulb after the test. Thus, significance can be attached to noting, with the results, such findings as: coke more or less fills the bulb; liquid material is present, either as limpid residue or drops; the residue is not black and flaky, but is colored and pulverulent (presumably from presence of inorganic materials).

10. Special Procedure

10.1 *Test on 10 % Distillation Residue*—This procedure is applicable to light distillate oils such as ASTM Nos. 1 and 2 fuel oils.

10.1.1 Assemble the distillation apparatus described in Specification E 133 using flask *D* (250-mL bulb volume), flask support board with 51-mm diameter opening, and graduated cylinder *C* (200-mL capacity). A thermometer is not required but the use of the ASTM High Distillation Thermometer 8F or 8C as prescribed in Specification E 1 or of the IP High Distillation Thermometer 6C, as prescribed in the IP Thermometer Specification, is recommended.

10.1.2 Place a volume of sample equivalent to 200 mL at 13 to 18°C in the flask. Maintain the condenser bath at 0 to 4°C (for some oils it may be necessary to hold the temperature between 38 and 60°C to avoid solidification of waxy material in the condenser tube). Use, without cleaning, the cylinder from which the sample was measured as the receiver and place it so that the tip of the condenser does not touch the wall of the cylinder.

10.1.3 Apply heat to the flask at a uniform rate so regulated that the first drop of condensate exits from the condenser 10 to 15 min after initial application of heat. After the first drop falls, move the receiving cylinder so that the tip of the condenser tube touches the wall of the cylinder. Then regulate the heat so that the distillation proceeds at a uniform rate of 8 to 10 mL/min. Continue the distillation until 178 mL of distillate has been collected, then discontinue heating and allow the condenser to drain until 180 mL (90 % of the charge to the flask) has been collected in the cylinder.

10.1.4 Immediately replace the cylinder with a small Erlenmeyer flask and catch any final drainage in the flask. Add to this flask, while still warm, the residue left in the distilling flask, and mix well. The contents of the flask then represent a 10 % distillation residue from the original product.

10.1.5 While the distillation residue is warm enough to flow freely, place 4.0 ± 0.1 g of it into the previously weighed coking bulb. A hypodermic syringe provides a convenient means of performing this operation. After cooling, weigh the bulb and contents to the nearest 1 mg, and carry out the carbon

TABLE 1 Sample Sizes

Ramsbottom Carbon Residue, %	Sample Size, g
Less than 6.0	4.0 ± 0.1
6.0 to 14.0	1.0 ± 0.1
14.1 to 20.0	0.5 ± 0.1