



Designation: C 374 – 70 (Reapproved 1998)

Standard Test Methods for Fusion Flow of Porcelain Enamel Frits (Flow-Button Methods)¹

This standard is issued under the fixed designation C 374; the number immediately following the designation indicates the year of original adoption or, in the case of revision, the year of last revision. A number in parentheses indicates the year of last reapproval. A superscript epsilon (ε) indicates an editorial change since the last revision or reapproval.

1. Scope

1.1 These test methods cover evaluation of the relative fusion flow characteristics of samples of a given porcelain enamel frit by comparison with an established standard for that frit.

1.2 Two test methods are included, differing only in certain details of the samples and in the apparatus and procedure for preparation of test specimens. Both test methods give equally reproducible results and provide a satisfactory basis for comparison of fusion flow of the sample with that of the established standard.

1.2.1 *Test Method A* employs granular particles of frit to which a bonding agent has been added. Button specimens are formed under high pressure in a hydraulic press.

1.2.2 *Test Method B* employs crushed, sized particles of frit to which a bonding agent has been added. Button specimens are formed in a steel mold by hand.

1.3 *This standard does not purport to address all of the safety concerns, if any, associated with its use. It is the responsibility of the user of this standard to establish appropriate safety and health practices and determine the applicability of regulatory limitations prior to use.*

2. Referenced Document

2.1 *ASTM Standards:*

E 11 Specification for Wire-Cloth Sieves for Testing Purposes²

TEST METHOD A

3. Apparatus

3.1 *Mortar*, of hard steel, resistant to abrasion by the porcelain enamel frit, and conforming to the dimensions shown in Fig. 1.

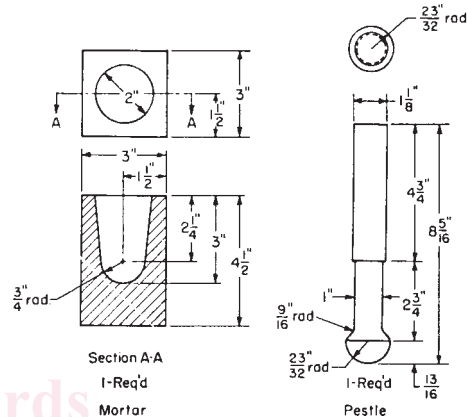

NOTE—1 in. = 25.4 mm.

FIG. 1 Mortar

NOTE 1—Suitable mortars are available commercially under the designation “tool steel crushing mortar.”

3.2 *Sieves*—No. 12 (1.70-mm) and No. 200 (75-μm) sieves conforming to Specification E 11.

NOTE 2—Tyler Standard Series sieves No. 12 (0.0060-in. (0.152-mm) openings) and No. 200 (0.029-in. (0.07-mm) openings) correspond to ASTM sieves Nos. 12 and 200 (U.S. Standard Sieves series numbers).

3.3 *Hydraulic Press*, capable of developing 3500-lbf (15 600 N) force (Fig. 2).

3.4 *Steel Mold Assembly*, consisting of a die and plunger, and having an inside diameter of 1/2 in. (12.7 mm) over its length of 2 1/8 in. (54 mm) as illustrated in Fig. 3.

3.5 *Fusion Flow Rack*, preferably constructed of heat-resisting alloy and conforming to the detailed requirements shown in Fig. 4.

4. Sample

4.1 A representative sample of the frit to be tested shall be obtained, mixed thoroughly, and reduced by quartering to about 25 g. This sample shall be crushed in a hard steel mortar to pass a No. 12 (1.70-mm) sieve and be retained on a No. 200 (75-μm) sieve.

¹ These test methods are under the jurisdiction of ASTM Committee B-8 on Metallic and Inorganic Coatings and are the direct responsibility of Subcommittee B08.12 on Materials for Porcelain Enamel and Ceramic-Metal Systems.

Current edition approved June 15, 1970. Published August 1970. Originally published as C 375 – 55. Last previous edition C 374 – 60 (1967).

² *Annual Book of ASTM Standards*, Vol 14.02.



FIG. 2 Hydraulic Press

5. Test Specimen

5.1 Weigh 3.5 ± 0.05 -g samples of the standard frit and of the material to be tested and thoroughly mix each of these samples with 4 or 5 drops of a 1 % gum arabic solution. Mold fusion button test specimens of the standard and of the sample as directed in 5.2.

5.2 Place the sample in the steel mold. Place the mold assembly containing the sample in a hydraulic press and bring the press up to 3000 to 3500 lbf (13.3 to 15.6 kN) total load, and immediately release (Fig. 2). Force the formed button out of the mold with the plunger, taking care not to damage the button in any way that might change the dimensions.

5.3 Dry the test specimens in a suitable oven at 100°C for 1 h.

NOTE 3—Special care must be exercised in drying buttons formed by this method, before firing, in order to prevent bloating and possible eruption of the button when first placed in the furnace.

6. Procedure

6.1 *Mounting*—Place the dried fusion buttons on a fired groundcoat plate. The location of the test specimens with respect to the standard may be modified as desired. Although the gage of metal used for the ground-coated plate is not of critical importance, most satisfactory results will be obtained when the metal is not heavier than 18 gage nor lighter than 22 gage (1.02 to 0.044 mm). Use the same gage of metal consistently from test to test in order to reduce the number of variables to a minimum. The groundcoat enamel used to coat the groundcoat plate shall have a median firing temperature no more than 50°F (28°C) below the median firing temperature for the most refractory frit being tested. Place the groundcoat plate with fusion buttons in place in a horizontal position on the fusion flow rack, which shall previously have been heated to furnace temperature, and place the entire test assembly in the furnace immediately.

6.2 *Firing*—Fire in a furnace in which the atmosphere is oxidizing and entirely free of any products of combustion. Heat distribution within the furnace shall be such that no portion of the fusion buttons will vary more than $\pm 5^\circ\text{F}$ ($\pm 3^\circ\text{C}$) from any

other button or portion thereof. The temperature shall approximate the median firing temperature for the standard that is used as a basis for comparison. Allow the buttons to remain in the horizontal position (Fig. 5(a)) until such time as fusion of the buttons is evident from the rounded appearance of the tops of the buttons. Then release the groundcoat plate to the vertical position (Fig. 5(b)) and allow the fusion buttons to flow a minimum of 50 mm, following which remove the test assembly from the furnace and allow the buttons to cool. When the flow is completed, the sides of the fusion buttons should be approximately parallel; that is, there should be no excessive spreading of the fusion buttons in the horizontal position, indicating that the buttons were allowed to remain in the horizontal position for too long a time.

6.3 *Measuring Flow*—Measure the greatest length of the fusion flow to the nearest 1 mm for each fusion button, including the standard.

7. Report

7.1 Report the length of the fusion flow for each test specimen in comparison with the standard run at the same time. For example, if a given specimen flows 50 mm against a flow for the standard of 55 mm, the results shall be reported as “50/55 mm.” If the width of the test specimen is observed to vary more than 10 % from the width of the standard, length-times-width values shall be calculated for the comparison.

TEST METHOD B

8. Apparatus

8.1 *Mortar*—See 3.1.

8.2 *Sieves*—No. 60 (250- μm) and No. 200 (75- μm) sieves conforming to Specification E 11.

NOTE 4—Tyler Standard Series sieves No. 60 (0.0097-in. openings) and No. 200 (0.0029-in. openings) correspond to ASTM sieves Nos. 60 and 200 (U.S. Standard Sieve series numbers).

8.3 *Steel Mold Assembly*, consisting of a die, plunger, and backup disk as shown in Fig. 6. The inside diameter of the mold shall be $\frac{1}{2}$ in. (12.7 mm) over its length of $1\frac{1}{4}$ in. (31.8 mm).

8.4 *Fusion Flow Rack*—See 3.5.

9. Sample

9.1 A representative sample of the frit to be tested shall be obtained, mixed thoroughly, and reduced by quartering to about 25 g. This sample shall be crushed by impact in a hard steel mortar to pass a No. 60 (250- μm) sieve and be retained on a No. 200 (75- μm) sieve. In order to avoid the excessive reduction of fines, they shall be removed frequently during the process of reduction by throwing the sample on the sieve and continuing the crushing of the coarser particles until all the sample passes through the sieve.

10. Preparation of Test Specimens

10.1 Weigh 3.5 ± 0.05 -g samples of the standard and of the material to be tested and thoroughly mix each of these samples