

**SLOVENSKI STANDARD**  
**SIST EN 3307:2001****01-januar-2001**

---

**Aerospace series - Screws, pan head, offset cruciform recess, threaded to head, in titanium alloy, anodized, MoS2 lubricated - Classification: 1 100 MPa (at ambient temperature)/315 °C**

Aerospace series - Screws, pan head, offset cruciform recess, threaded to head, in titanium alloy, anodized, MoS2 lubricated - Classification: 1 100 MPa (at ambient temperature)/315 °C

Luft- und Raumfahrt - Flachkopfschrauben mit Flügelkreuzschlitz, Gewinde annähernd bis Kopf, aus Titanlegierung, anodisiert, MoS2-geschmiert - Klasse: 1 100 MPa (bei Raumtemperatur)/315 °C

Série aérospatiale - Vis à tete cylindrique, a empreinte cruciforme déportée, filetées jusqu'a proximité de la tete, en alliage de titane, anodisées, lubrifiées MoS2 - Classification: 1 100 MPa (a température ambiante)/315 °C

**Ta slovenski standard je istoveten z: EN 3307:1996**

---

**ICS:**

49.030.20 Sorniki, vijaki, stebelni vijaki Bolts, screws, studs

**SIST EN 3307:2001****en**

**iTeh STANDARD PREVIEW**  
**(standards.iteh.ai)**

SIST EN 3307:2001

<https://standards.iteh.ai/catalog/standards/sist/e56cb554-4d5b-4c0d-b9ce-01b2f33818f6/sist-en-3307-2001>

EUROPEAN STANDARD

EN 3306

NORME EUROPÉENNE

EUROPÄISCHE NORM

August 1996

ICS 49.040.20

Descriptors: aircraft industry, screw, countersunk head screw, cross recessed screw, titanium alloy, specification, dimension, dimensional tolerance, surface treatment, designation, marking

English version

**Aerospace series - Screws, 100° countersunk normal head, offset cruciform recess, threaded to head, in titanium alloy, anodized, MoS<sub>2</sub> lubricated**  
**- Classification: 1 100 MPa (at ambient temperature)/315 °C**

Série aéronautique - Vis à tête fraisée 100° normale, à empreinte cruciforme déportée, filetées jusqu'à proximité de la tête, en alliage de titane, anodisées, lubrifiées MoS<sub>2</sub>  
 - Classification: 1 100 MPa (à température ambiante)/315 °C

Luft- und Raumfahrt - 100° Senkschrauben mit Flügelkreuzschlitz, Gewinde annähernd bis Kopf, aus Titanlegierung, anodisiert, MoS<sub>2</sub>-geschmiert  
 - Klasse: 1 100 MPa (bei Raumtemperatur)/315 °C

<https://standards.iteh.ai/catalog/standards/sist/e56cb554-4d5b-4c0d-b9ce-01b2f33818f6/sist-en-3307-2001>

This European Standard was approved by CEN on 1995-12-27. CEN members are bound to comply with the CEN/CENELEC Internal Regulations which stipulate the conditions for giving this European Standard the status of a national standard without any alteration.

Up-to-date lists and bibliographical references concerning such national standards may be obtained on application to the Central Secretariat or to any CEN member.

The European Standards exist in three official versions (English, French, German). A version in any other language made by translation under the responsibility of a CEN member into its own language and notified to the Central Secretariat has the same status as the official versions.

CEN members are the national standards bodies of Austria, Belgium, Denmark, Finland, France, Germany, Greece, Iceland, Ireland, Italy, Luxembourg, Netherlands, Norway, Portugal, Spain, Sweden, Switzerland and United Kingdom.

**CEN**

European Committee for Standardization  
 Comité Européen de Normalisation  
 Europäisches Komitee für Normung

Central Secretariat: rue de Stassart, 36 B-1050 Brussels

Page 2  
EN 3306:1996

**Foreword**

This European Standard has been prepared by the European Association of Aerospace Manufacturers (AECMA).

After inquiries and votes carried out in accordance with the rules of this Association, this Standard has received the approval of the National Associations and the Official Services of the member countries of AECMA, prior to its presentation to CEN.

This European Standard shall be given the status of a national standard, either by publication of an identical text or by endorsement, at the latest by February 1997, and conflicting national standards shall be withdrawn at the latest by February 1997.

According to the CEN/CENELEC Internal Regulations, the national standards organizations of the following countries are bound to implement this European Standard: Austria, Belgium, Denmark, Finland, France, Germany, Greece, Iceland, Ireland, Italy, Luxembourg, Netherlands, Norway, Portugal, Spain, Sweden, Switzerland and the United Kingdom.

**ITeH STANDARD PREVIEW**  
**(standards.iteh.ai)**

SIST EN 3307:2001

<https://standards.iteh.ai/catalog/standards/sist/e56cb554-4d5b-4c0d-b9ce-4b7b186c8e47/3307>

ALUMINIO IS PANI JAU 95%  
TIPU 01 TOLUVA AVTOSU AX QVITOMINI  
cylindrom ni cilindrinote os 011 bnu  
ANALJOUJ

.....T010  
EVTKAGSAAI HOVEDI ON TIEVERA



## 1 Scope

This standard specifies the characteristics of screws, 100° countersunk normal head, offset cruciform recess, threaded to head, in titanium alloy, anodized, MoS<sub>2</sub> lubricated.

Classification : 1 100 MPa <sup>1)</sup> / 315 °C <sup>2)</sup>

## 2 Normative references

This European Standard incorporates by dated or undated reference provisions from other publications. These normative references are cited at the appropriate places in the text and the publications are listed hereafter. For dated references, subsequent amendments to or revisions of any of these publications apply to this European Standard only when incorporated in it by amendment or revision. For undated references the latest edition of the publication referred to applies.

- ISO 3353 Aerospace - Rolled threads for bolts - Lead and runout requirements
- ISO 5855-2 Aerospace - MJ threads - Part 2 : Limit dimensions for bolts and nuts
- ISO 7913 Aerospace - Bolts and screws, metric - Tolerances of form and position
- ISO 7994 Aerospace - Internal drive, offset cruciform recess - (Torq-Set <sup>®</sup>) for rotary fastening devices - Metric series
- ISO 9152 Aerospace - Titanium alloy bolts, strength class 1 100 MPa, MJ threads - Procurement specification <sup>3)</sup> (standards.iteh.ai)
- EN 2000 Aerospace series - Quality assurance - EN aerospace products - Approval of the quality system of manufacturers <https://standards.iteh.ai/catalog/standards/sist/e56cb554-4d5b-4c0d-b9ce-01b2f33818f6/sist-en-3307-2001>
- EN 2424 Aerospace series - Marking of aerospace products
- EN 2491 Aerospace series - Molybdenum disulphide dry lubricants - Coating methods <sup>4)</sup>
- TR 3775 Aerospace series - Bolts and pins - National materials <sup>5)</sup>
- TR 4070 Aerospace series - Molybdenum disulphide dry lubricants - List of commercial products <sup>3)</sup>

1) Minimum tensile strength of the material at ambient temperature

2) Maximum temperature that the screw can withstand without continuous change in its original characteristics, after return to ambient temperature. The maximum temperature is determined by the surface treatment.

3) In preparation at the date of publication of this standard

4) Published as AECMA Standard at the date of publication of this standard

5) Published as AECMA Technical Report at the date of publication of this standard

### 3 Required characteristics

#### 3.1 Configuration - Dimensions - Masses

See figure 1 and table 1.

Dimensions and tolerances are expressed in millimetres and apply after anodizing but before lubricating.

#### 3.2 Tolerances of form and position

ISO 7913

#### 3.3 Materials

TR 3775 (titanium alloy, strength class 1 100 MPa)

#### 3.4 Surface treatment

Lubrication :

- lubricant : see TR 4070 ;
- application : EN 2491, 5  $\mu\text{m}$  to 10  $\mu\text{m}$ .

**iTeh STANDARD PREVIEW**  
**(standards.iteh.ai)**

SIST EN 3307:2001

<https://standards.iteh.ai/catalog/standards/sist/e56cb554-4d5b-4c0d-b9ce-01b2f33818f6/sist-en-3307-2001>

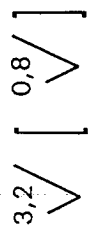

Values in micrometres apply prior to surface treatment.

Break sharp edges 0,1 to 0,4

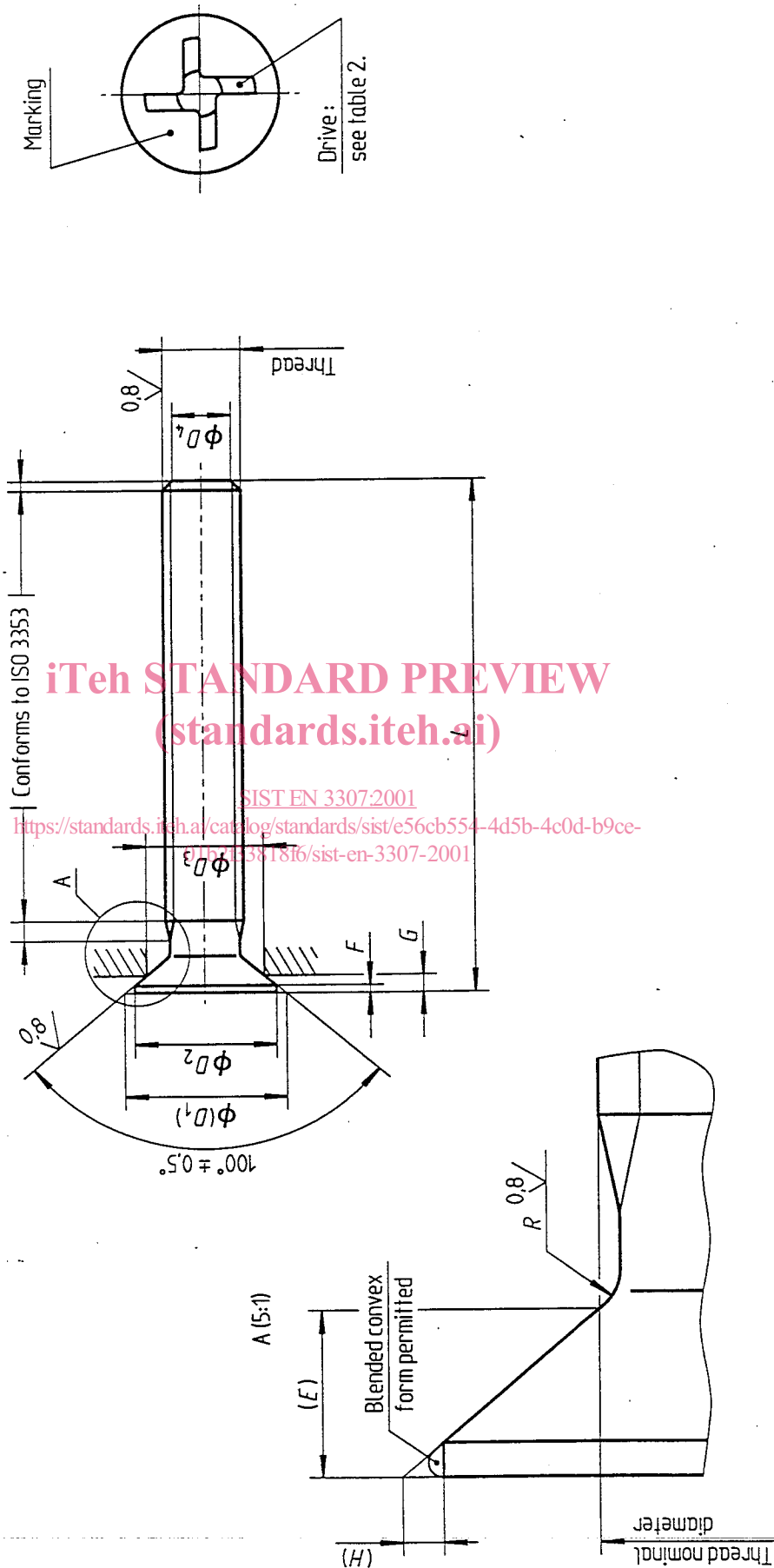

Figure 1

Table 1

Diameter code	Thread <sup>1)</sup>	D <sub>1</sub> max.	D <sub>2</sub> min.	D <sub>3</sub>	D <sub>4</sub>		E	F min.	G 0 - 0,08	H	L + 0,3 <sup>2) 3)</sup>		R		Mass <sup>4)</sup>	
					nom.	Tol.					Code	nom.	nom.	Tol.	5)	6)
030	MJ3x0,5 - 4h6h	6	5,4	4,5	2,3	0	1,27	0,06	0,63	0,3	006 to 042	6 to 42	0,4	0	0,22	0,11
040	MJ4x0,7 - 4h6h	8	7,2	5,78	3	- 0,5	1,69	0,08	0,93	0,4	008 to 056	8 to 56	0,4	0	0,53	0,20
050	MJ5x0,8 - 4h6h	10	9	7,71	3,4		2,12		0,96	0,5	010 to 070	10 to 70	0,5	0	1,02	0,33
060	MJ6x1 - 4h6h	12	10,8	9	4,2		2,54		1,26		012 to 084	12 to 84	0,5	- 0,2	1,78	0,44
070	MJ7x1 - 4h6h	14	12,8	10,28	5,2		2,96		1,57		012 to 098	12 to 98	0,7		2,54	0,60
080	MJ8x1 - 4h6h	16	14,8	12,21	6,2	+ 0,5	3,39	0,1	1,6	0,6	014 to 112	14 to 112	0,8		3,86	0,78
100	MJ10x1,25 - 4h6h	20	18,8	15,43	7,9		4,23		1,93		018 to 140	18 to 140	0,8		7,78	1,22
120	MJ12x1,25 - 4h6h	24	22,8	18	9,8		5,08		2,53		020 to 168	20 to 168	0,9	0	12,72	1,76

1) In accordance with ISO 5855-2

2) Increments :

2 for L ≤ 100

4 for L &gt; 100

3) If greater lengths are required, they shall be chosen using the above increments. The length code corresponds to the length L, completed by one or two zeros to the left, where necessary, to obtain a three digit code.

4) Approximate values (kg/1 000 pieces), calculated on the basis of 4,45 kg/dm<sup>3</sup>, given for information purposes only

5) Value for first L

6) Increase for each additional 2 mm of L.