



## Standard Test Method for Dynamic Surface Tension by the Fast-Bubble Technique<sup>1</sup>

This standard is issued under the fixed designation D 3825; the number immediately following the designation indicates the year of original adoption or, in the case of revision, the year of last revision. A number in parentheses indicates the year of last reapproval. A superscript epsilon ( $\epsilon$ ) indicates an editorial change since the last revision or reapproval.

### 1. Scope

1.1 This test method covers the determination of the specific free energy of a liquid-gas surface a short time after formation of the surface.

1.2 It is applicable to liquids with vapor pressures up to 30.0 kPa (225 torr) and kinematic viscosities up to 4.0 mm/s (4.0 cSt) at the test temperature. Higher viscosities have not yet been investigated.<sup>2</sup>

1.3 The values stated in SI units are to be regarded as the standard. The values given in parentheses are for information only.

1.4 *This standard does not purport to address all of the safety concerns, if any, associated with its use. It is the responsibility of the user of this standard to consult and establish appropriate safety and health practices and determine the applicability of regulatory limitations prior to use.* For specific precautionary statements, see 7.3, 7.4, and 7.5.

### 2. Referenced Documents

2.1 *ASTM Standards:*

D 1193 Specification for Reagent Water<sup>3</sup>

D 1331 Test Methods for Surface and Interfacial Tension of Solutions of Surface-Active Agents<sup>4</sup>

E 1 Specification for ASTM Thermometers<sup>5</sup>

### 3. Terminology

3.1 *Definitions:*

3.1.1 *surface tension* ( $\gamma$ )—the specific surface free energy of a liquid gas interface, millinewton per metre (ergs/cm<sup>2</sup>).

3.2 *Definitions of Terms Specific to This Standard:*

3.2.1 *bubble frequency* ( $S$ )—bubbling rate, s<sup>-1</sup>.

3.2.2 *dead time* ( $t_o$ )—time required from start to completion of a bubble, ms.

3.2.3 *surface age* ( $t$ )—time required to start a new bubble, ms.

3.2.4 *dead time %*—fraction of a cycle ( $t + t_o$ ) in the dead state, %.

<sup>1</sup> This test method is under the jurisdiction of ASTM Committee D-2 on Petroleum Products and Lubricants and is the direct responsibility of Subcommittee D02.11 on Engineering Science of High Performance Fluids and Solids.

Current edition approved Oct. 26, 1990. Published December 1990.

<sup>2</sup> Kloubek, J., "Measurement of the Dynamic Surface Tension by the Maximum Bubble Pressure Method, III," *Journal of Colloid and Interface Science*, Vol. 41, October 1972, pp. 7–16.

<sup>3</sup> *Annual Book of ASTM Standards*, Vol 11.01.

<sup>4</sup> *Annual Book of ASTM Standards*, Vol 15.04.

<sup>5</sup> *Annual Book of ASTM Standards*, Vol 14.03.

3.2.5 *bubble pressure* ( $\Delta P$ )—difference between maximum pressures for the wide capillary ( $P_1$ ) and the narrow capillary ( $P_2$ ), Pa.

3.3 *Symbols:*

$\gamma$  = surface tension, millinewtons per metre (dynes/cm)

$S$  = bubble frequency, s<sup>-1</sup>

$t_o$  = dead time, ms

$t$  = surface age, ms

$D$  = density, kg/m<sup>3</sup>

$r$  = radius, mm

$\Delta P$  = difference between maximum pressures, Pa

$P_1$  = maximum pressure for the wide capillary, Pa

$P_2$  = maximum pressure for the narrow capillary, Pa

### 4. Summary of Test Method

4.1 The pressure required for bubble formation at a capillary tip immersed in the liquid is measured at gas flow rates that provide a series of bubble frequencies. The pressure and a calibration constant are used to calculate the dynamic surface tension at various surface ages.

### 5. Significance and Use

5.1 While this test method can be applied to pure liquids, it is especially designed for use with mixtures in which one or more components migrate to the surface.

5.2 Data of this type are needed for the design of equipment for processing mixed liquids, such as in distillation towers.

### 6. Apparatus

6.1 *Bubbler Unit*, water-jacketed, as shown in Fig. 1.

6.2 *Thermostat*, circulating water, to hold bubbler at specified temperature.

6.3 *Oven*, adjustable to 378 K (105°C), explosion-proof.

6.4 *Pressure Transducer*, diaphragm-resistive unbonded strain gage, time constant 25 ms or less, 0 to 2000 Pa, accuracy  $\pm 2\%$ .<sup>6,7</sup>

6.5 *Bridge Power Supply*, for the strain gage.

6.6 *Oscilloscope*, capable of sweep times down to 0.020 s.

6.7 *Filtered (5- $\mu$ m) Air Supply*, with pressure regulator capable of 0 to 724 kPa (0 to 105 psig) above ambient.

<sup>6</sup> Razouk, R. "Surface Tension of Propellants," JPL Quarterly Technical Review Vol 2, 1972, pp. 123–133.

<sup>7</sup> Razouk, R. and Walmsley, D., "Surface Tension Measurement by the Differential Maximum Bubble Pressure Method Using a Pressure Transducer," *Journal of Colloid and Interface Science*, Vol. 47, 1974, pp. 515–519.

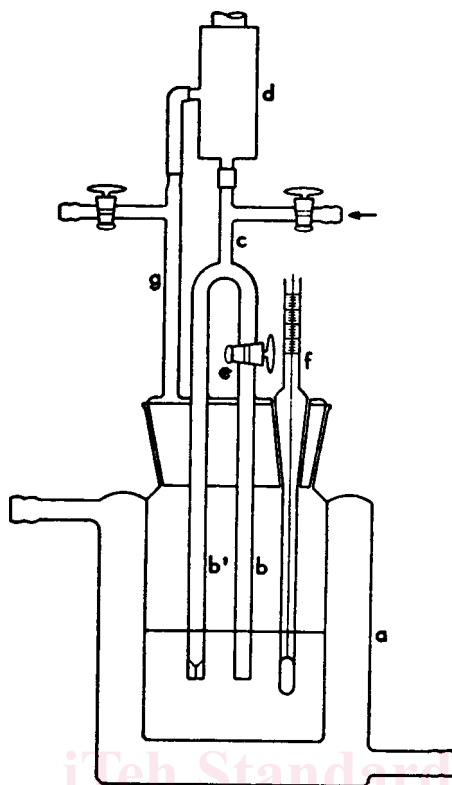

Tips of *b* and *b'* shall be cut squarely at exactly the same level, and finely ground (for example, 44  $\mu\text{m}$  S;C (320 mesh S;C)).

FIG. 1 Bubbler Unit

NOTE 1—Nitrogen shall be used in place of air if there is any problem of oxidizing the liquid.

6.8 *Thermometer*, appropriate range, conforming to Specification E 1.

## 7. Reagents and Materials

7.1 *Purity of Reagents*—Reagent grade chemicals shall be used in all tests. Unless otherwise indicated, it is intended that all reagents shall conform to the specification of the Committee on Analytical Reagents of the American Chemical Society,<sup>8</sup> where such specifications are available. Other grades may be used, provided it is first ascertained that the reagent is of sufficiently high purity to permit its use without lessening the accuracy of the determination.

7.2 *Purity of Water*—Unless otherwise indicated, references to water shall be understood to mean reagent water conforming to Specification D 1193, Type III.

7.3 *Calibration Liquids*, reagent grade, covering a wide range of surface tension.

NOTE 2—Acetone, toluene, ethanol, and methanol have been found satisfactory for this purpose. *Acetone*—**Warning:** Extremely flammable.

<sup>8</sup> *Reagent Chemicals, American Chemical Society Specifications*, American Chemical Society, Washington, DC. For suggestions on the testing of reagents not listed by the American Chemical Society, see *Analar Standards for Laboratory Chemicals*, BDH Ltd., Poole, Dorset, U.K., and the *United States Pharmacopeia and National Formulary*, U.S. Pharmaceutical Convention, Inc. (USPC), Rockville, MD.

Vapors may cause flash fire. See Annex A1.1. *Toluene*—**Warning:** Flammable. Vapor harmful. See Annex A1.6. *Methanol*—**Warning:** Flammable. Vapor harmful. See Annex A1.5. *Ethanol*—**Warning:** Flammable. Denatured. See Annex A1.4.

7.4 *Cleaning Solution*, Chromic-sulfuric acid. **Warning:** Causes severe burns. A recognized carcinogen strong oxidizer, contact with organic material can cause fire. Hygroscopic. See Annex A1.2.

7.5 *Nitrogen*, of purity suitable to avoid reaction with test liquid and less than 100 ppm CO<sub>2</sub> with amines. **Warning:** Compressed gas under high pressure. See Annex A1.3.

## 8. Calibration and Standardization

8.1 Clean the bubbler with cleaning solution, and rinse with water. **Warning:** Causes severe burns. A recognized carcinogen. Strong oxidizer, contact with organic material may cause fire. Hygroscopic. See Annex A1.2. Condition by soaking in water for 48 h followed by a final rinse with water.

8.2 Set up the apparatus as shown in Fig. 2, and bring the thermostat to the desired temperature.

NOTE 3—If a test temperature is not specified, 298  $\pm$  0.1 K (25  $\pm$  0.1°C) is recommended.

8.3 Calibrate the transducer and the oscilloscope vertical scale against a suitable timer.

8.4 Measure the inner radius (*r*) of the wide capillary (*b*) by any suitable means to  $\pm$  5 %.

8.5 Half-fill the bubbler with water; then connect it to