



Standard Test Method for Nitrogen in Petroleum and Petroleum Products by Boat-Inlet Chemiluminescence¹

This standard is issued under the fixed designation D 5762; the number immediately following the designation indicates the year of original adoption or, in the case of revision, the year of last revision. A number in parentheses indicates the year of last reappraisal. A superscript epsilon (ϵ) indicates an editorial change since the last revision or reappraisal.

1. Scope *

1.1 This test method covers the determination of nitrogen in liquid hydrocarbons, including petroleum process streams and lubricating oils in the concentration range from 40 to 10 000 $\mu\text{g/g}$ nitrogen. For light hydrocarbons containing less than 100 $\mu\text{g/g}$ nitrogen, Test Method D 4629 can be more appropriate.

1.2 The values stated in SI units are to be regarded as the standard. The values given in parentheses are for information only.

1.3 *This standard does not purport to address all of the safety concerns, if any, associated with its use. It is the responsibility of the user of this standard to establish appropriate safety and health practices and determine the applicability of regulatory limitations prior to use.* Specific hazard statements are given in Section 6, 7.1, 8.2, and 8.2.2.

2. Referenced Documents

2.1 ASTM Standards:

D 4052 Test Method for Density and Relative Density of Liquids by Digital Density Meter²

D 4057 Practice for Manual Sampling of Petroleum and Petroleum Products²

D 4177 Practice for Automatic Sampling of Petroleum and Petroleum Products²

D 4629 Test Method for Trace Nitrogen in Liquid Petroleum Hydrocarbons by Syringe/Inlet Oxidative Combustion and Chemiluminescence Detection²

3. Summary of Test Method

3.1 A hydrocarbon sample is placed on a sample boat at room temperature. The sample and boat are advanced into a high-temperature combustion tube where the nitrogen is oxidized to nitric oxide (NO) in an oxygen atmosphere. The NO contacts ozone and is converted to excited nitrogen dioxide (NO_2). The light emitted as the excited NO_2 decays is detected by a photomultiplier tube, and the resulting signal is a measure of the nitrogen contained in the sample.

¹ This test method is under the jurisdiction of ASTM Committee D02 on Petroleum Products and Lubricants and is the direct responsibility of Subcommittee D02.03 on Elemental Analysis.

Current edition approved May 10, 2001. Published June 2001. Originally published as D 5762 – 95. Last previous edition D 5762 – 98.

² *Annual Book of ASTM Standards*, Vol 05.02.

4. Significance and Use

4.1 Many nitrogen compounds can contaminate refinery catalysts. They tend to be the most difficult class of compounds to hydrogenate, so the nitrogen content remaining in the product of a hydrotreater is a measure of the effectiveness of the hydrotreating process. In lubricating oils the concentration of nitrogen is a measure of the presence of nitrogen containing additives. This test method is intended for use in plant control and in research.

5. Apparatus

5.1 *Boat Inlet System*, capable of being sealed to the inlet of the combustion tube and swept with inert gas. The boats are fabricated from platinum or quartz. To aid quantitative liquid injection, add a small piece of quartz wool to the boat. The boat drive mechanism should be able to fully insert the boat into the furnace tube inlet section. A drive mechanism that advances and withdraws the sample boat into and out of the furnace at a controlled and repeatable rate is required.

5.2 *Chemiluminescence Detector*, capable of measuring light emitted from the reaction between nitric oxide and ozone, and containing a variable attenuation amplifier, integrator, and readout.

5.3 *Combustion Tube*, fabricated from quartz. The inlet end of the tube shall be large enough to accept the sample boat and to have side arms for introduction of oxygen and inert gas. The construction is such that the carrier gases sweep the inlet zone transporting all of the volatilized sample into a high-temperature oxidation zone. The oxidation section should be large enough to ensure complete oxidation of the sample. Combustion tubes recommended for the two furnaces in 5.5.1 and 5.5.2 are described in 5.3.1 and 5.3.2. Other configurations are acceptable if precision and bias are not degraded.

5.3.1 Quartz combustion tube for use with the single-zone furnace is illustrated in Fig. 1. A water-jacket around the inlet section can be used to cool the boat prior to sample injection.

5.3.2 Quartz combustion tube for use with the two-zone furnace is illustrated in Fig. 2. Fig. 3 illustrates a combustion tube for a two-zone furnace that is equipped with the ability to switch to a pure oxygen carrier gas flow after the boat has been fully extended into the furnace (consult the instrument manual to determine if the instrument changes to a pure oxygen carrier gas flow after the boat is inserted). The outlet end of the

*A Summary of Changes section appears at the end of this standard.

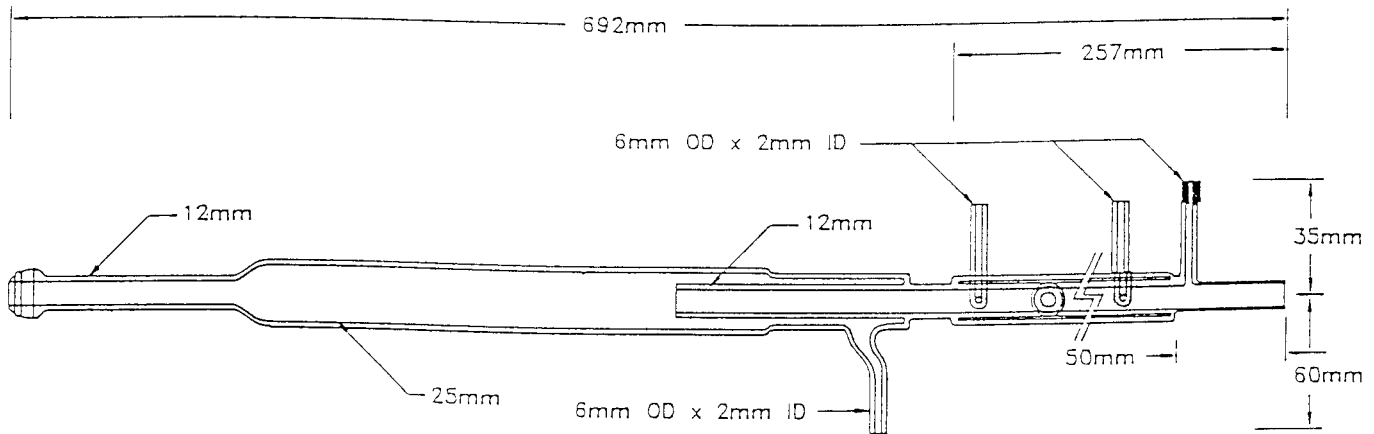

FIG. 1 Quartz Combustion Tube (Single-Zone Furnace)

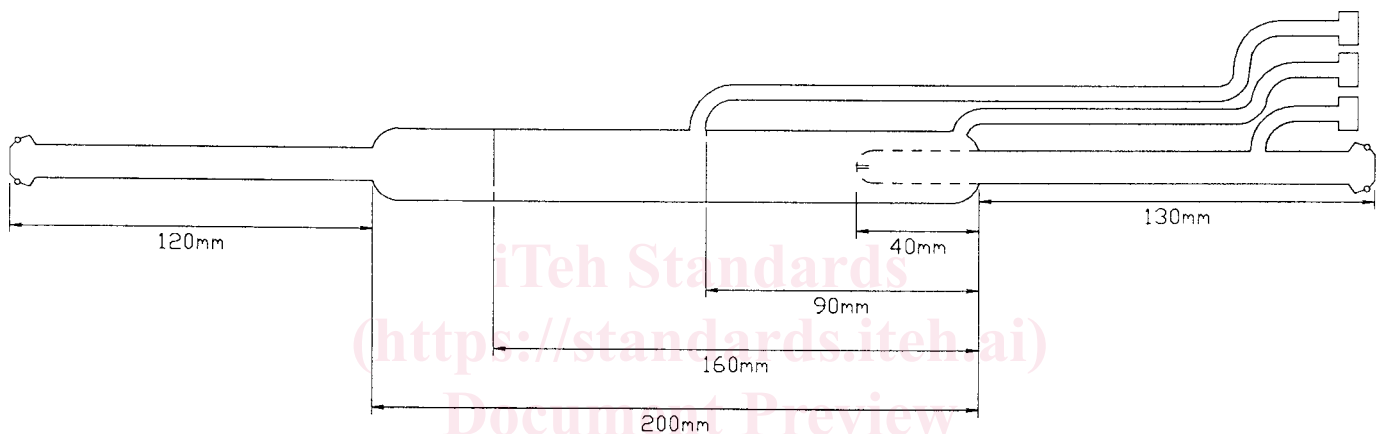

FIG. 2 Quartz Combustion Tube (Two-Zone Furnace)

pyrolysis tube is constructed to hold a removable quartz insert tube. The removable quartz insert tube is packed with an oxidation catalyst as recommended by the instrument manufacturer.

5.4 *Drier Tube*, for the removal of water vapor. The reaction products include water vapor that shall be eliminated prior to measurement by the detector. This can be accomplished with a magnesium perchlorate, $Mg(ClO_4)_2$, scrubber, a membrane drying tube permeation drier, or a chilled dehumidifier assembly.

5.5 *Furnace, Electric*, held at a temperature sufficient to pyrolyze all of the sample and oxidize the nitrogen to NO. The following furnace designs may be used. All furnace assemblies include a method for gas flow control, such as needle valves, flow restrictors or mass flow controllers. Furnaces that are operated at temperatures below 1050°C shall be capable of switching to 100% oxygen carrier gas flow after the boat has been fully extended into the furnace.

5.5.1 Single-zone tube furnace with temperature controller capable of maintaining a stable furnace temperature of 1100 ($\pm 25^\circ C$).

5.5.2 Two-zone tube furnace with temperature controllers capable of maintaining the temperature of each furnace zone independently from 950 to 1050°C (see 5.5). Or two-zone tube furnace equipped with the ability to change to a pure oxygen carrier gas flow after the boat is fully extended in to the furnace

and temperature controllers capable of maintaining the temperature of each furnace zone independently to 950°C.¹

5.6 *Microlitre Syringe*, of 5 or 10- μL capacity, capable of accurately delivering microlitre quantities.

5.7 *Ozone Generator*, to supply ozone to the detector reaction cell.

5.8 *Recorder (Optional)*, for display of chemiluminescence detector signal.

6. Reagents and Materials

6.1 *Purity of Reagents*—Reagent grade chemicals shall be used in all tests. Unless otherwise indicated, it is intended that all reagents shall conform to the specifications of the Committee on Analytical Reagents of the American Chemical Society where such specifications are available.³ Other grades may be used, provided it is first ascertained that the reagent is of sufficiently high purity to permit its use without lessening the accuracy of the determination.

6.2 *Acridine*, $C_{13}H_9N$, molecular weight 179.21, 7.82 mass % nitrogen. (**Warning**—Irritant.)

³ *Reagent Chemicals, American Chemical Society Specifications*, American Chemical Society, Washington, DC. For suggestions on the testing of reagents not listed by the American Chemical Society, see *Analar Standards for Laboratory Chemicals*, BDH Ltd., Poole, Dorset, U.K., and the *United States Pharmacopeia and National Formulary*, U.S. Pharmacopeial Convention, Inc. (USPC), Rockville, MD.

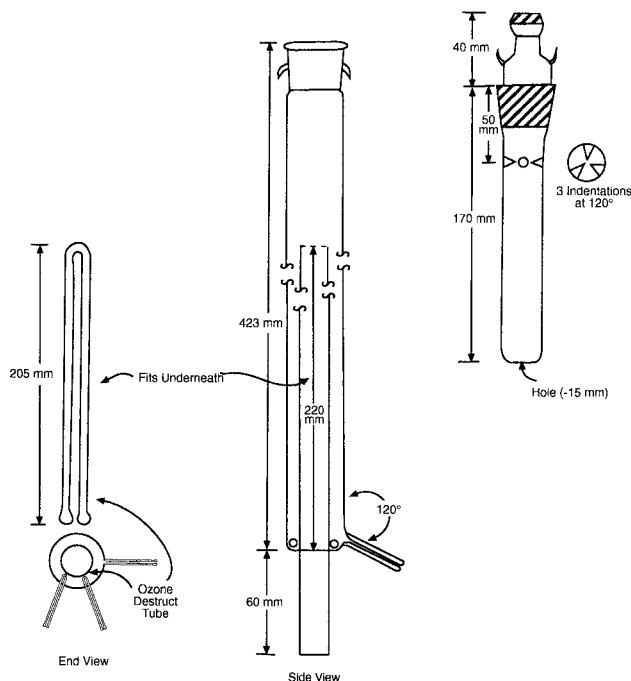

FIG. 3 Quartz Combustion Tube (for two zone furnace equipped with the ability to switch to pure oxygen carrier gas flow)

6.3 *Oxidation Catalyst: Cupric Oxide Wire, CuO, or Platinum Catalyst, PtAl₂O₃*, as recommended by the instrument manufacturer.

6.4 *Inert Gas*—Argon or Helium only, high-purity grade (that is, chromatographic or zero grade), 99.998 % minimum purity, 5 ppm maximum moisture.

6.5 *Anhydrous Magnesium Perchlorate, Mg(ClO₄)₂*, for drying products of combustion (if permeation drier or chilled drier is not used). (**Warning**—Strong oxidizer, irritant.)

6.6 *Nitrogen Stock Solution, 500 ng nitrogen/μL*—Accurately weigh (to the nearest 0.1 mg) approximately 0.64 g of acridine into a tared 100-mL volumetric flask. Add xylene to dissolve, then dilute to volume with xylene. Calculate the nitrogen content of the stock solution to the nearest milligram of nitrogen per litre. This stock can be further diluted to desired nitrogen concentrations. (**Warning**—Remake standard solutions on a regular basis depending upon frequency of use and age. Typically, standards have a useful life of approximately three months.)

6.7 *Oxygen*, high-purity grade (that is, chromatographic or zero grade), 99.75 % minimum purity, 5 ppm maximum moisture, dried over molecular sieves. (**Warning**—Vigorously accelerates combustion.)

6.8 *Quartz Wool*.

6.9 *Silver Wool*, as recommended by the instrument manufacturer.

6.10 *Xylene*. (**Warning**—Flammable, health hazard.)

7. Sampling

7.1 Obtain a test sample in accordance with Practice D 4057 or D 4177. (**Warning**—Samples that are collected at temperatures below room temperature can undergo expansion at laboratory temperatures and rupture the container. For such samples, do not fill the container to the top. Leave sufficient air

space above the sample to allow room for expansion.) (**Warning**—To minimize loss of volatile components, which can be present in some test samples, do not uncover any longer than necessary. Test samples should be analyzed as soon as possible after taking from bulk supplies to prevent loss of nitrogen or contamination due to exposure or contact with sample container.)

7.2 If the test sample is not used immediately, then thoroughly mix it in its container prior to taking a test specimen. Some test samples require heating in order to thoroughly homogenize.

8. Preparation of Apparatus

8.1 Assemble apparatus in accordance with the manufacturer's instructions.

8.2 Adjust the oxygen flow for the ozone generator in accordance with the manufacturer's instructions. Adjust the combustion tube gas flows and the pyrolysis temperature to the desired operating conditions using the following guidelines for each furnace type. (**Warning**—Ozone is extremely toxic. Make sure that appropriate steps are taken to prevent discharge of ozone within the laboratory work area.)

8.2.1 For the single-zone furnace without the ability to change to a pure oxygen carrier gas flow after the boat has been fully extended into the furnace, adjust the combustion tube gas flows to the following values: pyrolysis oxygen, 360 mL/min; inlet oxygen, 60 mL/min; and inert carrier inlet, 155 mL/min. Set the furnace temperature to 1100 ± 25°C. Adjust the boat drive mechanism to obtain a drive rate of 150 ± 10 mm/min. Refer to the manufacturer's instructions for descriptions of these settings.

8.2.2 For the two-zone furnace without the ability to change to a pure oxygen carrier gas flow after the boat has been fully extended into the furnace, adjust the combustion tube gas flows