



Designation: D 5853 – 95

An American National Standard



Designation: 441/99

## Standard Test Method for Pour Point of Crude Oils<sup>1</sup>

This standard is issued under the fixed designation D 5853; the number immediately following the designation indicates the year of original adoption or, in the case of revision, the year of last revision. A number in parentheses indicates the year of last reapproval. A superscript epsilon ( $\epsilon$ ) indicates an editorial change since the last revision or reapproval.

### 1. Scope

1.1 This test method covers two procedures for the determination of the pour point temperatures of crude oils down to  $-36^{\circ}\text{C}$ . One method provides a measure of the maximum (upper) pour point temperature (Procedure A) and is described in 9.1; the other method provides a measure of the minimum (lower) pour point temperature (Procedure B) and is described in 9.2.

1.2 The use of this test method is limited to use for crude oils. Pour point temperatures of other petroleum products can be determined by Test Method D 97.

1.3 *This standard does not purport to address all of the safety concerns, if any, associated with its use. It is the responsibility of the user of this standard to establish appropriate safety and health practices and determine the applicability of regulatory limitations prior to use.* For specific hazard statements, see Section 7.

### 2. Referenced Documents

#### 2.1 ASTM Standards:

- D 97 Test Method for Pour Point of Petroleum Products<sup>2</sup>
- D 130 Test Method for Detection of Copper Corrosion from Petroleum Products by the Copper Strip Tarnish Test<sup>2</sup>
- D 323 Test Method for Vapor Pressure of Petroleum Products (Reid Method)<sup>2</sup>
- D 4057 Practice for Manual Sampling of Petroleum and Petroleum Products<sup>3</sup>
- D 4177 Practice for Automatic Sampling of Petroleum and Petroleum Products<sup>3</sup>
- E 1 Specification for ASTM Thermometers<sup>4</sup>
- E 77 Test Method for Inspection and Verification of Thermometers<sup>4</sup>

### 3. Terminology

#### 3.1 Definitions of Terms Specific to This Standard:

<sup>1</sup> This test method is under the jurisdiction of ASTM Committee D-2 on Petroleum Products and Lubricants and is the direct responsibility of Subcommittee D02.07 on Flow Properties.

Current edition approved Oct. 10, 1995. Published December 1995.

<sup>2</sup> *Annual Book of ASTM Standards*, Vol 05.01.

<sup>3</sup> *Annual Book of ASTM Standards*, Vol 05.02.

<sup>4</sup> *Annual Book of ASTM Standards*, Vol 14.03.

3.1.1 *pour point, n*—the lowest temperature at which movement of the test specimen is observed under the conditions of the test.

3.1.2 *maximum (upper) pour point, n*—the pour point obtained after the test specimen has been subjected to a prescribed treatment designed to enhance gelation of wax crystals and solidification of the test specimen.

3.1.3 *minimum (lower) pour point, n*—the pour point obtained after the test specimen has been subjected to a prescribed treatment designed to delay gelation of wax crystals and solidification of the test specimen.

### 4. Summary of Test Method

4.1 After preliminary heating, the test specimen is cooled at a specified rate and examined at intervals of  $3^{\circ}\text{C}$  for flow characteristics. The lowest temperature at which movement of the test specimen is observed is recorded as the pour point.

### 5. Significance and Use

5.1 The pour point of a crude oil is an index of the lowest temperature of handleability for certain applications.

5.2 This is the only pour point method specifically designed for crude oils.

5.3 The maximum and minimum pour point temperatures provide a temperature window where a crude oil, depending on its thermal history, might appear in the liquid as well as the solid state.

5.4 The test method can be used to supplement other measurements of cold flow behavior. It is especially useful for the screening of the effect of wax interaction modifiers on the flow behavior of crude oils.

### 6. Apparatus

#### 6.1 Pour Point Test Apparatus Assembly (see Fig. 1):

6.1.1 *Test Jar*, cylindrical, of clear glass, flat bottomed, outside diameter 33.2 to 34.8 mm, and height 115 to 125 mm. The inside diameter of the jar can range from 30.0 to 32.4 mm, within the constraint that the wall thickness shall be no greater than 1.6 mm. The jar shall have a line to indicate a sample height  $54 \pm 3$  mm above the inside bottom. The inside of the test jar (up to the mark) shall be visibly clean and free of scratches.

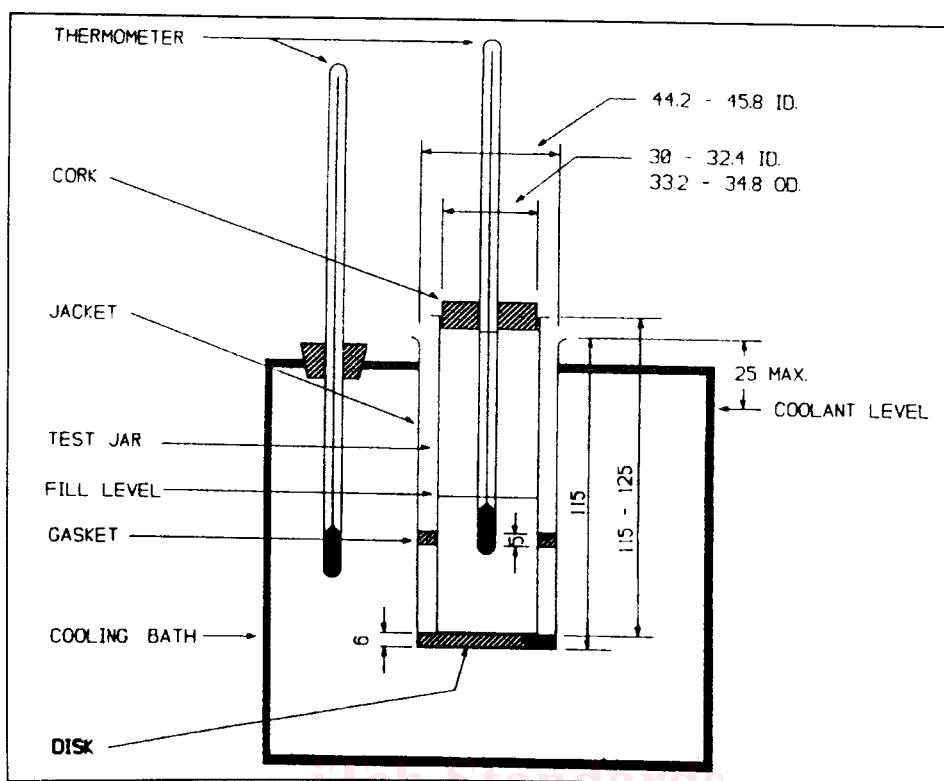

NOTE 1—All dimensions are stated in millimetres.

FIG. 1 Apparatus for Pour Point Test

6.1.2 *Thermometers*, having ranges shown in the following table and conforming to the requirements prescribed in Specification E 1 for thermometers:

Thermometer	Temperature Range	Thermometer	
		ASTM	IP
High cloud and pour	-38 to +50°C	5C	1C
Low cloud and pour	-80 to +20°C	6C	2C
Melting point	+32 to +127°C	61C	63C

6.1.2.1 Since separation of liquid column thermometers occasionally occurs and may escape detection, the ice point of the thermometers shall be checked prior to the test and used only if they are accurate within  $\pm 1^\circ\text{C}$  (see Test Method E 77).

6.1.3 *Cork*, to fit the test jar, center bored for the test thermometer.

6.1.4 *Jacket*, watertight, cylindrical, metal, flat bottomed,  $115 \pm 3$  mm depth, with inside diameter of 44.2 to 45.8 mm. It shall be supported in a vertical position in the cooling bath (6.1.7) so that no more than 25 mm projects out of the cooling medium. The jacket shall be capable of being cleaned.

6.1.5 *Disk*, cork or felt, 6 mm thick to fit loosely inside the jacket.

6.1.6 *Gasket*, to fit snugly around the outside of the test jar and loosely inside the jacket. The gasket shall be made of rubber, leather, or other material that is sufficiently elastic to cling to the test jar and hard enough to hold its shape. Its purpose is to prevent the test jar from touching the jacket.

6.1.7 *Cooling Bath or Baths*, of a type suitable for obtaining the required temperatures. The size and shape of the bath are optional, but a support to hold the jacket firmly in a vertical

position is essential. The bath temperature shall be monitored by means of the appropriate thermometer (6.1.2) or any other temperature measuring device capable of measuring and displaying the designated temperature with the required precision and accuracy. The required bath temperatures shall either be maintained by refrigeration or by suitable freezing mixtures (Note 1) and shall maintain the designated temperatures to within  $\pm 1.5^\circ\text{C}$ .

NOTE 1—The cooling mixtures commonly used are as follows<sup>5</sup>:

	For Temperatures Down To
Ice and water	9°C
Crushed ice and sodium chloride crystals	-12°C
Crushed ice and calcium chloride crystals	-27°C
Acetone or petroleum naphtha (see Section 7) chilled in a covered metal beaker with an ice-salt mixture to -12°C and then with enough solid carbon dioxide to give the desired temperature.	-57°C

6.2 *Water Bath*—The size and shape of the bath are optional, but a support to hold the test jar immersed in the bath to above the sample height in the test jar and in a firm vertical position is required. The required bath temperature may be maintained by any suitable means, provided the temperature can be monitored and controlled to the designated temperature ( $\pm 1^\circ\text{C}$  (9.1.4; 9.2.4)).

6.3 *Pressure Vessel*,<sup>6</sup> constructed of stainless steel according

<sup>5</sup> This pressure vessel is identical to the pressure vessel described in Test Method D 130.

<sup>6</sup> The results of the cooperative test program from which these values have been derived are filed at ASTM Headquarters. Request RR:D02-1371.

to the dimensions given in Fig. 2, and capable of withstanding a test pressure of 700 kPa. Alternative designs for the pressure vessel cap and synthetic rubber gasket may be used provided that the internal dimensions of the pressure vessel are the same as those shown in Fig. 2.

6.4 *Timing Device*, capable of measuring up to 30 s with a resolution of at least 0.1 s and an accuracy of  $\pm 0.2$  s or better.

**7. Reagents and Materials**

7.1 The following solvents of technical grade are appropriate for low-temperature bath media.

7.1.1 *Acetone.*

NOTE 2—**Warning:** Extremely flammable.

7.1.2 *Alcohol, Ethanol.*

NOTE 3—**Warning:** Flammable.

7.1.3 *Alcohol, Methanol.*

NOTE 4—**Warning:** Flammable. Vapor harmful.

7.1.4 *Petroleum Naphtha.*

NOTE 5—**Warning:** Combustible. Vapor harmful.

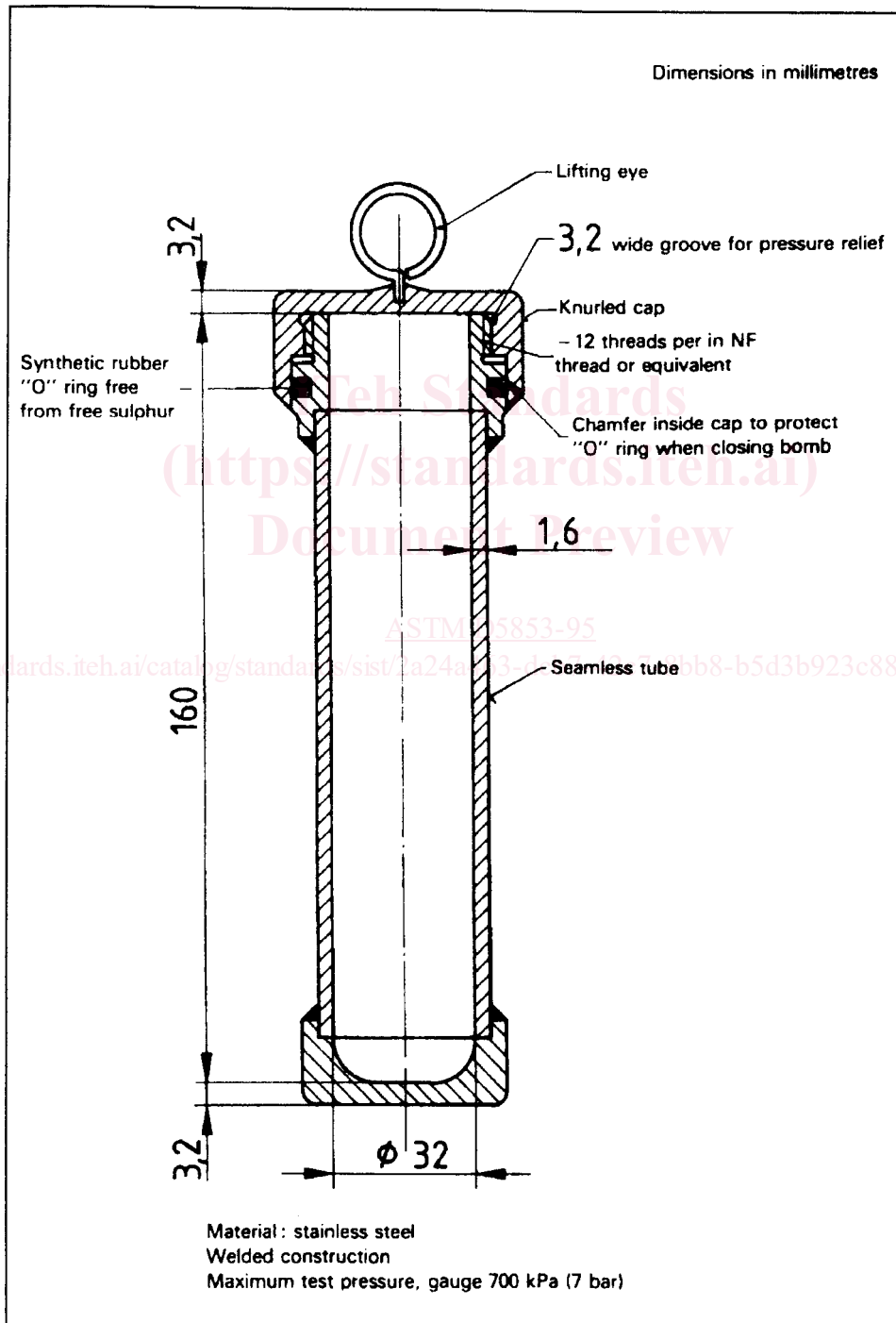

FIG. 2 Pressure Vessel