**Optics and optical instruments —
Microscopes — Information provided to the
user**

*Optique et instruments d'optique — Microscopes — Informations délivrées
à l'utilisateur*

iTeh STANDARD PREVIEW
(standards.iteh.ai)

ISO 12853:1997

[https://standards.iteh.ai/catalog/standards/sist/3ef61767-4559-4d9c-8a66-
d522dc40f8b5/iso-12853-1997](https://standards.iteh.ai/catalog/standards/sist/3ef61767-4559-4d9c-8a66-d522dc40f8b5/iso-12853-1997)



Foreword

ISO (the International Organization for Standardization) is a worldwide federation of national standards bodies (ISO member bodies). The work of preparing International Standards is normally carried out through ISO technical committees. Each member body interested in a subject for which a technical committee has been established has the right to be represented on that committee. International organizations, governmental and non-governmental, in liaison with ISO, also take part in the work. ISO collaborates closely with the International Electrotechnical Commission (IEC) on all matters of electrotechnical standardization.

Draft International Standards adopted by the technical committees are circulated to the member bodies for voting. Publication as an International Standard requires approval by at least 75 % of the member bodies casting a vote.

International Standard ISO 12853 was prepared by Technical Committee ISO/TC 172, *Optics and optical instruments*, Subcommittee SC 5, *Microscopes and endoscopes*.

iTeh STANDARD PREVIEW
(standards.iteh.ai)
ISO 12853:1997
<https://standards.iteh.ai/catalog/standards/sist/3ef61767-4559-4d9c-8a66-d522dc40f8b5/iso-12853-1997>

© ISO 1997

All rights reserved. Unless otherwise specified, no part of this publication may be reproduced or utilized in any form or by any means, electronic or mechanical, including photocopying and microfilm, without permission in writing from the publisher.

International Organization for Standardization
Case postale 56 • CH-1211 Genève 20 • Switzerland
Internet central@iso.ch
X.400 c=ch; a=400net; p=iso; o=isocs; s=central

Printed in Switzerland

Optics and optical instruments — Microscopes — Information provided to the user

1 Scope

This International Standard specifies the minimum required information to be provided to the user by the microscope manufacturer.

In addition to the mandatory microscope information **(m)**, further data are recommended **(r)**.

2 Normative reference

The following standard contains provisions which, through reference in this text, constitute provisions of this International Standard. At the time of publication, the edition indicated was valid. All standards are subject to revision, and parties to agreements based on this International Standard are encouraged to investigate the possibility of applying the most recent edition of the standard indicated below. Members of IEC and ISO maintain registers of currently valid International Standards.

ISO 8578:1996, *Optics and optical instruments — Microscopes — Marking of objectives and eyepieces*.

3 Data provided by the manufacturer

The data indicated **(m)** shall be provided by the manufacturer when the respective microscope assemblies feature the properties described. Provision of microscope data indicated **(r)** is recommended but not required.

3.1 General information

3.1.1 Details of origin

3.1.1.1 **(m)** Manufacturer

3.1.1.2 **(r)** Country of origin, if required

3.1.2 **(r)** Field of application

Examples: Schools and courses, laboratories, research, industry.

3.1.3 **(m)** Imaging and illumination methods

Examples: Transmitted light, reflected light, brightfield, darkfield, phase contrast, differential interference contrast, polarization, fluorescence.

3.1.4 (r) Accessories

Examples: Photographic equipment, alternative light sources, manipulators, photometric equipment, image processing equipment, video equipment.

3.2 Design information

3.2.1 Stand

3.2.1.1 (r) Type of stand

Examples: Upright stand, inverted stand.

3.2.1.2 Dimensions of stand, expressed in millimetres (see figure 1)

- a) **(m)** l_1, l_2 Base dimensions (measured in x and y directions);
- b) **(m)** l_3 Overall mechanical height (without attachments);
- c) **(m)** l_5 Distance from exit pupil to base plane (65 mm interpupillary distance);
- d) **(m)** l_7 Distance from exit pupil to focus drive (65 mm interpupillary distance);
- e) (r) l_4 Maximum height of stage surface from base plane;
- f) (r) l_6 Distance from focus drive to base plane;
- g) (r) l_8 Distance between exit pupil and optical axis.

3.2.1.3 (r) Mass of the stand, expressed in kilograms (including body tube, but without attachments)

3.2.1.4 (r) Interchangeability of components at the stand

Examples: Viewing tube, stage, substage, lamp housing, nosepiece.

3.2.1.5 Adjustment integrated in the stand

- a) **(m)** Coarse adjustment affecting the stage or the body tube;
- b) **(m)** operating range of coarse adjustment, in millimetres;
- c) **(m)** fine adjustment affecting the stage or the body tube;
- d) (r) operating range of fine adjustment, in millimetres;
- e) (r) movement of fine adjustment per scale division or rotation, in micrometres;
- f) (r) movement of coarse adjustment per rotation, in millimetres.

3.2.1.6 (r) Slots integrated in the stand

3.2.1.7 (m) Tube factor q different from $1\times$ (if tube lens is located in the stand)

3.2.2 Microscope tube

- a) **(m)** Monocular, binocular or trinocular tube;
- b) **(m)** interpupillary distance adjustment range, in millimetres;
- c) **(m)** tube factor q different from $1\times$ (if the tube lens is located in the tube);
- d) **(m)** inclination angle α of the viewing direction (see figure 1);
- e) **(m)** inside diameter of the eyepiece tube(s) (23,2 mm or 30 mm);
- f) (r) diopter adjustment;
- g) (r) tube length compensation;

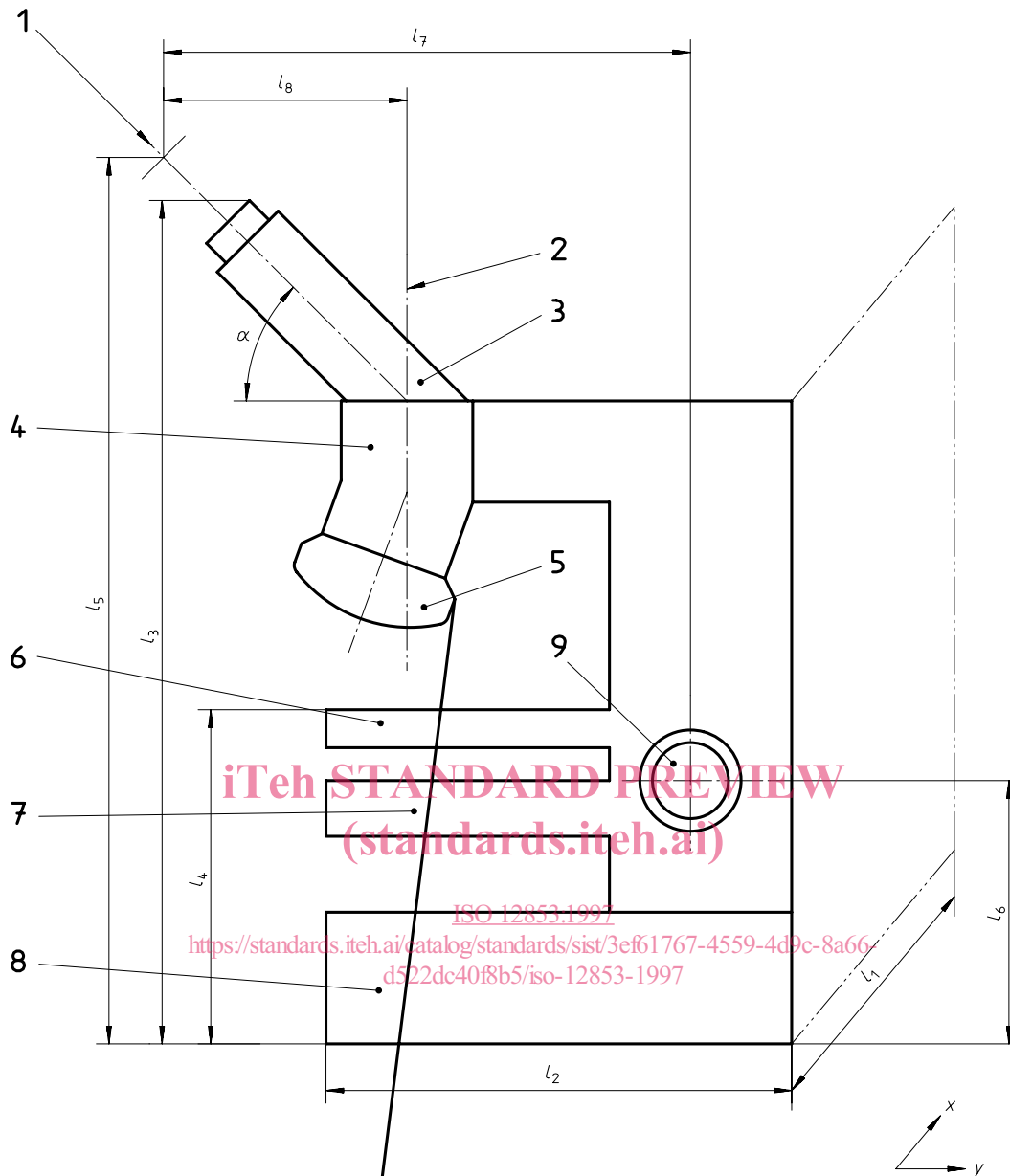

iTeh STANDARD PREVIEW
(standards.iteh.ai)

ISO 12853:1997

<https://standards.iteh.ai/catalog/standards/sist/3ef61767-4559-4d9c-8a66-d522dc40f8b5/iso-12853-1997>

- | | |
|----------------|-----------------|
| 1 Exit pupil | 6 Stage |
| 2 Optical axis | 7 Substage |
| 3 Viewing tube | 8 Base of stand |
| 4 Body tube | 9 Focus drive |
| 5 Nosepiece | |

Figure 1 — Dimensions of the stand

- h) (r) focal length of the tube lens (if the tube lens is corrected for infinite primary image distance);
- i) (r) splitting ratio(s) of the beam splitter(s);
- j) (r) distance l_8 between exit pupil and optical axis (see figure 1).

3.2.3 Nosepiece

- a) (m) Number of mounting holes for objectives;

- b) (m) objective centration;
- c) (r) dimensions of screw thread other than the RMS thread.

3.2.4 Objectives

The objectives suitable for use with the related microscope shall be listed, with the following data in accordance with ISO 8578.

- a) (m) Magnification;
- b) (m) numerical aperture;
- c) (m) state of correction, field of view and colour;
- d) (m) immersion medium (other than air);
- e) (m) tube length, in millimetres;
- f) (m) cover glass thickness, in millimetres;
- g) (m) contrast methods;
- h) (m) suitability for polarized-light microscopy;
- i) (m) iris diaphragm;
- j) (m) free working distance, in millimetres;
- k) (m) correction collar.

iTeh STANDARD PREVIEW
(standards.iteh.ai)

3.2.5 Eyepieces

The eyepieces suitable for use with the related microscope shall be listed, with the following data in accordance with ISO 8578.

- a) (m) Magnification;
- b) (m) field of view;
- c) (m) diameter of eyepiece (23,2 mm or 30 mm);
- d) (r) type of correction;
- e) (r) interchangeability of graticules;
- f) (r) suitability for spectacle wearers;
- g) (r) diopter adjustment.

3.2.6 Condenser

- a) (m) Maximum numerical aperture;
- b) (m) suitability for contrast methods;
- c) (r) type of correction;
- d) (r) range of objectives at a given field of view;
- e) (r) free working distance, in millimetres;
- f) (r) illuminating aperture diaphragm;
- g) (r) filter holder;
- h) (r) interchangeability;
- i) (r) slide thickness, in millimetres.

3.2.7 Illuminating system

3.2.7.1 (r) Substage

Examples: Interchangeability, centring possibility for the condenser, filter holder, polarizing device, illuminated field diaphragm for transmitted light.

3.2.7.2 (r) Vertical illuminator for incident light

Examples: Illuminating aperture diaphragm, illuminated field diaphragm, slots for accessories, polarizing device, centring possibility of diaphragms.

3.2.8 Light source

- a) **(m)** Arrangement of the light source (incorporated in the stand or lamp housing attached to the stand);
- b) **(m)** type of light source (halogen, mercury arc, xenon arc, etc.);
- c) **(m)** model number;
- d) **(m)** voltage and wattage of the light source;
- e) **(m)** kind of current (a.c. or d.c.);
- f) (r) colour temperature of the light source at rated voltage;
- g) (r) rated lifetime of the light source.

3.2.9 Power supply

- a) **(m)** Main supply voltage (V a.c.);
- b) **(m)** main supply frequency (50 Hz and/or 60 Hz);
- c) **(m)** power consumption (V A);
- d) **(m)** fuse (type rated amperage);
- e) **(m)** built-in or external;
- f) **(m)** output adjustable or fixed.

iTeh STANDARD PREVIEW
 (standards.iteh.ai)
 ISO 12853:1997
<https://standards.iteh.ai/catalog/standards/sist/3ef61767-4559-4d9c-8a66-d522dc40f8b5/iso-12853-1997>

iTeh STANDARD PREVIEW
(standards.iteh.ai)

ISO 12853:1997

<https://standards.iteh.ai/catalog/standards/sist/3ef61767-4559-4d9c-8a66-d522dc40f8b5/iso-12853-1997>

ICS 37.020

Descriptors: optics, optical equipment, microscopes, optical microscopes, consumer information, technical data sheets.

Price based on 5 pages
