



# SLOVENSKI STANDARD

## SIST EN 3435:2010

01-marec-2010

5 YfcbUj h\_U!`NU\_cj bY'a UhjWZgUa cnUd]fUbYZdfYa ] bYZXj cgfUbg\_YZg\_fUyUbU  
gYf]Užn]nj fh]bc`nUj ]U\_YZ]n`hd`ctbccXdcfbY[ U^Y\_`Uža UnUbY`n`AcG&!  
?`Ug]Z\_UW^U.`%&\$`ADUfd]f]hYa dYfUi f]`c\_c`]Wt# %` š7

Aerospace series - Nuts, anchor, self-locking, floating, two lug, reduced series, with counterbore, in heat resisting steel, MoS2 lubricated - Classification: 1100 MPa (at ambient temperature)/315 °C

**iTeh STANDARD PREVIEW**  
(standards.iteh.ai)

Luft- und Raumfahrt - Annietsmuttern, selbstsichernd, beweglich, beiderseitiger verkürzter Flansch, mit zylindrischer Aussenkantung, aus hochwarmfestem Stahl, MoS2-geschmiert - Klasse: 1100 MPa (bei Raumtemperatur)/315 °C

[SIST EN 3435:2010](https://standards.iteh.ai/catalog/standards/sist/b1e65317-dc36-410d-b03e-36a10c1a9e31/en-3435-2010)

<https://standards.iteh.ai/catalog/standards/sist/b1e65317-dc36-410d-b03e-36a10c1a9e31/en-3435-2010>  
Série aérospatiale - Écrous à river, à freinage interne, flottants, double patte, série réduite, avec chambrage, en acier résistant à chaud, lubrifiés MoS2 - Classification: 1100 MPa (à température ambiante)/315 °C

**Ta slovenski standard je istoveten z: EN 3435:2010**

### ICS:

49.030.30 Matice Nuts

**SIST EN 3435:2010 en,de**

**iTeh STANDARD PREVIEW**  
**(standards.iteh.ai)**

SIST EN 3435:2010

<https://standards.iteh.ai/catalog/standards/sist/b1e65317-dc36-410d-b03e-6657200c07c2/sist-en-3435-2010>

EUROPEAN STANDARD  
NORME EUROPÉENNE  
EUROPÄISCHE NORM

**EN 3435**

January 2010

ICS 49.030.30

English Version

**Aerospace series - Nuts, anchor, self-locking, floating, two lug, reduced series, with counterbore, in heat resisting steel, MoS<sub>2</sub> lubricated - Classification: 1 100 MPa (at ambient temperature) / 315 °C**

Série aérospatiale - Écrous à river, à freinage interne, flottants, double patte, série réduite, avec chambrage, en acier résistant à chaud, lubrifiés MoS<sub>2</sub> - Classification: 1 100 MPa (à température ambiante) / 315 °C

Luft- und Raumfahrt - Anniemuttern, selbstsichernd, beweglich, beiderseitiger verkürzter Flansch, mit zylindrischer Aussenkung, aus hochwarmfestem Stahl, MoS<sub>2</sub>-geschmiert - Klasse: 1 100 MPa (bei Raumtemperatur) / 315 °C

This European Standard was approved by CEN on 11 December 2009.

CEN members are bound to comply with the CEN/CENELEC Internal Regulations which stipulate the conditions for giving this European Standard the status of a national standard without any alteration. Up-to-date lists and bibliographical references concerning such national standards may be obtained on application to the CEN Management Centre or to any CEN member.

This European Standard exists in three official versions (English, French, German). A version in any other language made by translation under the responsibility of a CEN member into its own language and notified to the CEN Management Centre has the same status as the official versions.

CEN members are the national standards bodies of Austria, Belgium, Bulgaria, Croatia, Cyprus, Czech Republic, Denmark, Estonia, Finland, France, Germany, Greece, Hungary, Iceland, Ireland, Italy, Latvia, Lithuania, Luxembourg, Malta, Netherlands, Norway, Poland, Portugal, Romania, Slovakia, Slovenia, Spain, Sweden, Switzerland and United Kingdom.



EUROPEAN COMMITTEE FOR STANDARDIZATION  
COMITÉ EUROPÉEN DE NORMALISATION  
EUROPÄISCHES KOMITEE FÜR NORMUNG

**Management Centre: Avenue Marnix 17, B-1000 Brussels**

**Contents**

Page

Foreword.....	3
1 Scope .....	4
2 Normative references .....	4
3 Required characteristics .....	5
4 Designation .....	7
5 Marking .....	7
6 Technical specification .....	7

**iTeh STANDARD PREVIEW**  
**(standards.iteh.ai)**

SIST EN 3435:2010

<https://standards.iteh.ai/catalog/standards/sist/b1e65317-dc36-410d-b03e-6657200c07c2/sist-en-3435-2010>

## Foreword

This document (EN 3435:2010) has been prepared by the Aerospace and Defence Industries Association of Europe - Standardization (ASD-STAN).

After enquiries and votes carried out in accordance with the rules of this Association, this Standard has received the approval of the National Associations and the Official Services of the member countries of ASD, prior to its presentation to CEN.

This European Standard shall be given the status of a national standard, either by publication of an identical text or by endorsement, at the latest by July 2010, and conflicting national standards shall be withdrawn at the latest by July 2010.

Attention is drawn to the possibility that some of the elements of this document may be the subject of patent rights. CEN [and/or CENELEC] shall not be held responsible for identifying any or all such patent rights.

According to the CEN/CENELEC Internal Regulations, the national standards organizations of the following countries are bound to implement this European Standard: Austria, Belgium, Bulgaria, Croatia, Cyprus, Czech Republic, Denmark, Estonia, Finland, France, Germany, Greece, Hungary, Iceland, Ireland, Italy, Latvia, Lithuania, Luxembourg, Malta, Netherlands, Norway, Poland, Portugal, Romania, Slovakia, Slovenia, Spain, Sweden, Switzerland and the United Kingdom.

**ITEH STANDARD PREVIEW**  
**(standards.iteh.ai)**

SIST EN 3435:2010

<https://standards.iteh.ai/catalog/standards/sist/b1e65317-dc36-410d-b03e-6657200c07c2/sist-en-3435-2010>

**EN 3435:2010 (E)****1 Scope**

This standard specifies the characteristics of two lug, reduced series, counterbored floating anchor nuts, with a self-locking feature achieved by forming the upper portion out-of-round, in heat resisting steel, MoS<sub>2</sub> lubricated.

Classification: 1 100 MPa<sup>1)</sup> / 315 °C<sup>2)</sup>.

**2 Normative references**

The following referenced documents are indispensable for the application of this document. For dated references, only the edition cited applies. For undated references, the latest edition of the referenced document (including any amendments) applies.

EN 2398, *Aerospace series — Heat resisting steel FE-PA2601 (X6NiCrTiMoV26-15) —  $R_m \geq 900$  MPa — Bars for machined bolts —  $D \leq 25$  mm*

EN 2399, *Aerospace series — Heat resisting steel FE-PA2601 (X4NiCrTiMoV26-15) —  $R_m \geq 900$  MPa — Bars for forged bolts —  $D \leq 25$  mm*

EN 2424, *Aerospace series — Marking of aerospace products*

EN 2491, *Aerospace series — Molybdenum disulphide dry lubricants — Coating methods*

EN 3638, *Aerospace series — Heat resisting alloy FE-PA2601 (X6NiCrTiMoV26-15) — Consumable electrode remelted — Solution and precipitation treated — Sheet, strip and plate —  $0,5 \text{ mm} \leq a \leq 10 \text{ mm}$*

EN 3639, *Aerospace series — Heat resisting alloy FE-PA2601 — Softened and cold worked — Wire for forged fasteners —  $D \leq 15 \text{ mm}$  —  $900 \text{ MPa} \leq R_m \leq 1 100 \text{ MPa}$ <sup>3)</sup>*

EN 3816, *Aerospace series — FE-PA3601 (X6CrNiTi18-10) — Air melted — Softened and cold rolled — Sheet and strip —  $a \leq 3 \text{ mm}$  —  $R_m \geq 800 \text{ MPa}$*

EN 9100, *Quality Management Systems — Requirements for Aviation, Space and Defense Organizations*

EN 9133, *Aerospace series — Quality management systems — Qualification procedure for aerospace standard parts*

TR 3791, *Aerospace series — Materials for self-locking nuts, threaded inserts and screw thread inserts of temperature classes  $\leq 425 \text{ °C}$ <sup>4)</sup>*

ISO 5855-2, *Aerospace — MJ threads — Part 2: Limit dimensions for bolts and nuts*

ISO 5858, *Aerospace — Nuts, self-locking, with maximum operating temperature less than or equal to 425 °C — Procurement specification*

1) Corresponds to strength class of the associated bolt, the 100 % load of which it is able to withstand, when tested at ambient temperature, without breaking or cracking.

2) Maximum temperature that the nut is able to withstand, without permanent alteration to its original characteristics, after ambient temperature has been restored. The maximum temperature is conditioned by the surface treatment.

3) Published as ASD-STAN Prestandard at the date of publication of this standard.

4) Published as ASD-STAN Technical Report at the date of publication of this standard.

ISO 7332, Aerospace — Nuts, anchor, self-locking, floating, two lug, reduced series, with counterbore, with MJ threads, classifications: 1 100 MPa (at ambient temperature)/235 °C, 1 100 MPa (at ambient temperature)/315 °C and 1 100 MPa (at ambient temperature)/425 °C — Dimensions

ISO 8788, Aerospace — Nuts, metric — Tolerances of form and position

### 3 Required characteristics

#### 3.1 Configuration — Dimensions — Masses

See Figure 1 and Table 1.

Dimensions and tolerances are in conformity with ISO 7332, expressed in millimetres and apply before MoS<sub>2</sub> lubrication.

Form and position tolerances shall be in conformity with ISO 8788 and those specified in Table 1.

#### 3.2 Materials

Threaded element: EN 2398, EN 2399, EN 3638, EN 3639 or TR 3791.

Cage: EN 3638 or EN 3816.

#### 3.3 Surface treatment

EN 2491, thickness not specified.

**ITeh STANDARD PREVIEW**  
**(standards.iteh.ai)**

SIST EN 3435:2010

<https://standards.iteh.ai/catalog/standards/sist/b1e65317-dc36-410d-b03e-6657200c07c2/sist-en-3435-2010>

## EN 3435:2010 (E)

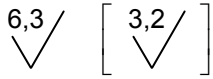

These values in micrometres apply before surface treatment. The values do not apply to threads and sheared edges the surface texture of which will be achieved by usual manufacturing methods.

Remove sharp edges 0,1 to 0,4.

Details of form not stated are at the manufacturer's option.

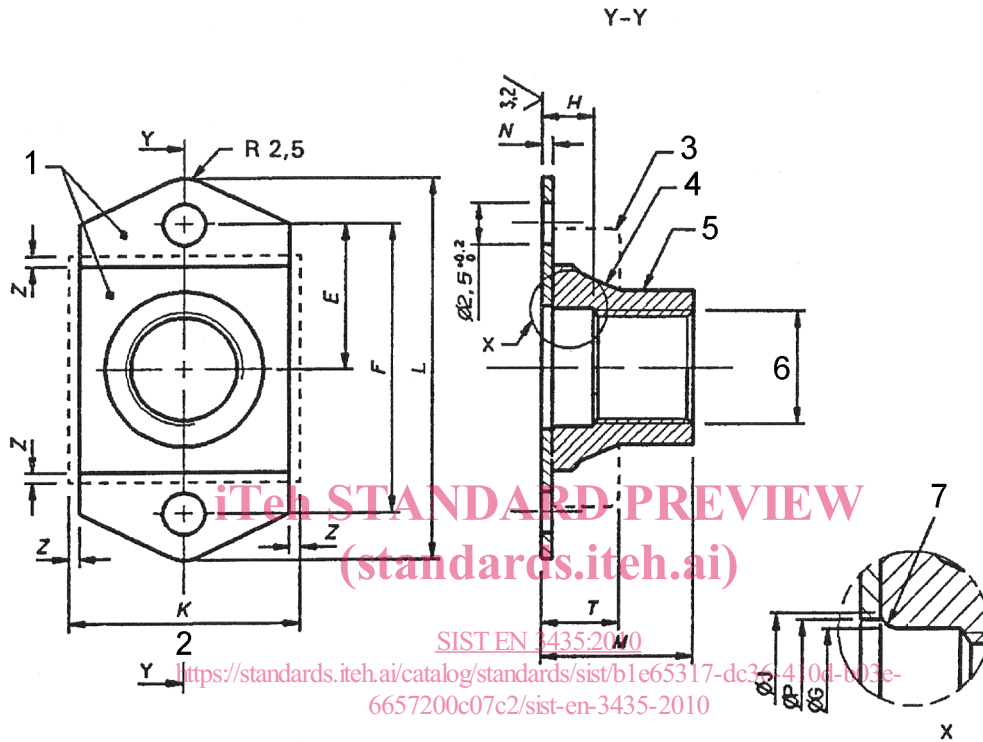

## Key

- 1 Marking
- 2 Float inclusive
- 3 Cage
- 4 Threaded element
- 5 Form out-of-round in this area to achieve self-locking. Tooling marks are permitted in this area.
- 6 Thread
- 7 Radius or chamfer

Figure 1