

INTERNATIONAL STANDARD

NORME INTERNATIONALE

**Connectors for electronic equipment – Tests and measurements –
Part 9-3: Endurance tests – Test 9c: Mechanical operation (engaging and
separating) with electrical load**

**Connecteurs pour équipements électroniques – Essais et mesures –
Partie 9-3: Essais d'endurance – Essai 9c: Fonctionnement mécanique
(d'accouplement et de désaccouplement) avec charge électrique**



THIS PUBLICATION IS COPYRIGHT PROTECTED

Copyright © 2011 IEC, Geneva, Switzerland

All rights reserved. Unless otherwise specified, no part of this publication may be reproduced or utilized in any form or by any means, electronic or mechanical, including photocopying and microfilm, without permission in writing from either IEC or IEC's member National Committee in the country of the requester.

If you have any questions about IEC copyright or have an enquiry about obtaining additional rights to this publication, please contact the address below or your local IEC member National Committee for further information.

Droits de reproduction réservés. Sauf indication contraire, aucune partie de cette publication ne peut être reproduite ni utilisée sous quelque forme que ce soit et par aucun procédé, électronique ou mécanique, y compris la photocopie et les microfilms, sans l'accord écrit de la CEI ou du Comité national de la CEI du pays du demandeur.

Si vous avez des questions sur le copyright de la CEI ou si vous désirez obtenir des droits supplémentaires sur cette publication, utilisez les coordonnées ci-après ou contactez le Comité national de la CEI de votre pays de résidence.

IEC Central Office
3, rue de Varembe
CH-1211 Geneva 20
Switzerland
Email: inmail@iec.ch
Web: www.iec.ch

About the IEC

The International Electrotechnical Commission (IEC) is the leading global organization that prepares and publishes International Standards for all electrical, electronic and related technologies.

About IEC publications

The technical content of IEC publications is kept under constant review by the IEC. Please make sure that you have the latest edition, a corrigenda or an amendment might have been published.

- Catalogue of IEC publications: www.iec.ch/searchpub

The IEC on-line Catalogue enables you to search by a variety of criteria (reference number, text, technical committee,...). It also gives information on projects, withdrawn and replaced publications.

- IEC Just Published: www.iec.ch/online_news/justpub

Stay up to date on all new IEC publications. Just Published details twice a month all new publications released. Available on-line and also by email.

www.iec.ch/online_news/justpub

- Electropedia: www.electropedia.org

The world's leading online dictionary of electronic and electrical terms containing more than 20 000 terms and definitions in English and French, with equivalent terms in additional languages. Also known as the International Electrotechnical Vocabulary online.

- Customer Service Centre: www.iec.ch/webstore/custserv

If you wish to give us your feedback on this publication or need further assistance, please visit the Customer Service Centre FAQ or contact us:

Email: csc@iec.ch

Tel.: +41 22 919 02 11

Fax: +41 22 919 03 00

A propos de la CEI

La Commission Electrotechnique Internationale (CEI) est la première organisation mondiale qui élabore et publie des normes internationales pour tout ce qui a trait à l'électricité, à l'électronique et aux technologies apparentées.

A propos des publications CEI

Le contenu technique des publications de la CEI est constamment revu. Veuillez vous assurer que vous possédez l'édition la plus récente, un corrigendum ou amendement peut avoir été publié.

- Catalogue des publications de la CEI: www.iec.ch/searchpub/cur_fut-f.htm

Le Catalogue en-ligne de la CEI vous permet d'effectuer des recherches en utilisant différents critères (numéro de référence, texte, comité d'études,...). Il donne aussi des informations sur les projets et les publications retirées ou remplacées.

- Just Published CEI: www.iec.ch/online_news/justpub

Restez informé sur les nouvelles publications de la CEI. Just Published détaille deux fois par mois les nouvelles publications parues. Disponible en-ligne et aussi par email.

- Electropedia: www.electropedia.org

Le premier dictionnaire en ligne au monde de termes électroniques et électriques. Il contient plus de 20 000 termes et définitions en anglais et en français, ainsi que les termes équivalents dans les langues additionnelles. Egalement appelé Vocabulaire Electrotechnique International en ligne.

- Service Clients: www.iec.ch/webstore/custserv/custserv_entry-f.htm

Si vous désirez nous donner des commentaires sur cette publication ou si vous avez des questions, visitez le FAQ du Service clients ou contactez-nous:

Email: csc@iec.ch

Tél.: +41 22 919 02 11

Fax: +41 22 919 03 00



IEC 60512-9-3

Edition 2.0 2011-06

INTERNATIONAL STANDARD

NORME INTERNATIONALE

**Connectors for electronic equipment – Tests and measurements –
Part 9-3: Endurance tests – Test 9c: Mechanical operation (engaging and
separating) with electrical load**

**Connecteurs pour équipements électroniques – Essais et mesures –
Partie 9-3: Essais d'endurance – Essai 9c: Fonctionnement mécanique
(d'accouplement et de désaccouplement) avec charge électrique**

INTERNATIONAL
ELECTROTECHNICAL
COMMISSION

COMMISSION
ELECTROTECHNIQUE
INTERNATIONALE

PRICE CODE
CODE PRIX

J

ICS 31.220.01

ISBN 978-2-88912-550-0

CONTENTS

FOREWORD.....	3
1 Scope and object.....	5
2 Normative references	5
3 Preparation	6
3.1 Preparation of specimen.....	6
3.2 Mounting	6
4 Test method	6
4.1 General	6
4.2 Electrical load	6
4.3 Mechanical operation	6
4.4 Environmental test conditions.....	7
4.5 Measurements.....	7
4.5.1 Initial measurements	7
4.5.2 Measurements during the test.....	7
4.5.3 Final measurements	7
5 Details to be specified	7
Annex A (informative) Typical circuit diagram	9
Figure A.1 – Example of circuit(s) – (diagrammatic).....	9
Figure A.2 – Example of circuit(s) – (circuit diagram).....	9

iTeh STANDARD PREVIEW

(standards.iteh.ai)

[IEC 60512-9-3:2011](https://standards.iteh.ai/catalog/standards/sist/99231975-ce2d-4103-92a7-4b01bdf77486/iec-60512-9-3-2011)

<https://standards.iteh.ai/catalog/standards/sist/99231975-ce2d-4103-92a7-4b01bdf77486/iec-60512-9-3-2011>

This standard is to be read in conjunction with IEC 60512-1 and IEC 60512-1-100, which explains the structure of the IEC 60512 series.

The text of this standard is based on the following documents:

FDIS	Report on voting
48B/2238/FDIS	48B/2244/RVD

Full information on the voting for the approval of this standard can be found in the report on voting indicated in the above table.

This publication has been drafted in accordance with the ISO/IEC Directives, Part 2.

A list of all parts in the IEC 60512 series, under the general title *Connectors for electronic equipment – Tests and measurements*, can be found on the IEC website.

The committee has decided that the contents of this publication will remain unchanged until the stability date indicated on the IEC web site under "<http://webstore.iec.ch>" in the data related to the specific publication. At this date, the publication will be

- reconfirmed,
- withdrawn,
- replaced by a revised edition, or
- amended.

ITEH STANDARD PREVIEW
(standards.iteh.ai)

[IEC 60512-9-3:2011](https://standards.iteh.ai/catalog/standards/sist/99231975-ce2d-4103-92a7-4b01bdf77486/iec-60512-9-3-2011)

<https://standards.iteh.ai/catalog/standards/sist/99231975-ce2d-4103-92a7-4b01bdf77486/iec-60512-9-3-2011>

CONNECTORS FOR ELECTRONIC EQUIPMENT – TESTS AND MEASUREMENTS –

Part 9-3: Endurance tests – Test 9c: Mechanical operation (engaging and separating) with electrical load

1 Scope and object

This part of IEC 60512, when required by the detail specification, is used for testing connectors within the scope of IEC technical committee 48. This test may also be used for similar devices when specified in a detail specification.

The object of this standard is to define a standard test method to assess the mechanical and electrical operational endurance, i.e. engaging and separating cycles, of a connector in an operating mode which includes a specified electrical load.

2 Normative references

The following referenced documents are indispensable for the application of this document. For dated references, only the edition cited applies. For undated references, the latest edition of the referenced document (including any amendments) applies.

IEC 60068-1, *Environmental testing – Part 1: General and guidance*

[https://standards.iteh.ai/catalog/standards/sist/99231975-ce2d-4103-92a7-](https://standards.iteh.ai/catalog/standards/sist/99231975-ce2d-4103-92a7-4b01bdf77486/iec-60512-9-3-2011)

IEC 60068-2-13, *Environmental testing – Part 2-13: Tests – Test M: Low air pressure*

IEC 60512-1, *Connectors for electronic equipment – Tests and measurements – Part 1: General*

IEC 60512-1-1, *Connectors for electronic equipment – Tests and measurements – Part 1-1: General examination – Test 1a: Visual examination*

IEC 60512-1-100, *Connectors for electronic equipment – Tests and measurements – Part 1-100: General – Applicable publications*

IEC 60512-2-1, *Connectors for electronic equipment – Tests and measurements – Part 2-1: Electrical continuity and contact resistance tests – Test 2a: Contact resistance – Millivolt level method*

IEC 60512-2-2, *Connectors for electronic equipment – Tests and measurements – Part 2-2: Electrical continuity and contact resistance tests – Test 2b: Contact resistance – Specified current method*

IEC 60512-3-1, *Connectors for electronic equipment – Tests and measurements – Part 3-1: Insulation tests – Test 3a: Insulation resistance*

IEC 60512-4-1, *Connectors for electronic equipment – Tests and measurements – Part 4-1: Voltage stress tests – Test 4a: Voltage proof*

3 Preparation

3.1 Preparation of specimen

The specimen shall consist of a component with its terminations and cables according to Clause 5, a), unless otherwise specified in the detail specification. Any preconditioning given in the detail specification shall be applied.

3.2 Mounting

The specimen under test shall be mounted per the manufacturer's instructions or as described in the detail specification.

4 Test method

4.1 General

The specimen shall be subjected to any electrical load and mechanical operational endurance test in accordance with the requirements of the detail specification or other applicable specification.

The specimen shall be operated (engaged/separated) to make and break the current load as specified in the detail specification or other applicable specification.

In the case of specimen(s) having more than one circuit, the circuits shall be wired in parallel, with appropriate duplication of other circuit components.

A circuit diagram, typical of that which may be specified, is shown in Annex A.

4.2 Electrical load

The type of electrical load, current, d.c. or a.c. voltage and frequency shall be stated in the detail specification or other applicable specification.

An 'equivalent circuit' is intended to simulate a typical wiring installation including electrical load and cable.

The equivalent circuit is specified by a resistance R, a capacitance C and an inductance L.

A typical circuit diagram is shown in Annex A.

In the case of specimen(s) having more than one circuit, the circuits shall be wired in parallel, with appropriate duplication of other circuit components.

During the mating cycles, the current and open-circuit voltage tolerances shall be within $\begin{matrix} +5 \\ 0 \end{matrix} \%$ of the rated values specified in the detail specification.

4.3 Mechanical operation

The specimen shall be operated (engaged and separated) to make and break the current load as specified below.

Speed, duty cycles and number of operations shall be stated in the detail specification or other applicable specification. One engaging and one separating constitutes one operation.

Mechanical aids which simulate normal operation without introducing abnormal stresses may be used unless otherwise specified by the detail specification.

The engaging and separating speed shall be (50 ± 5) mm/s, if not otherwise specified in the detail specification or other applicable specification.

There will be a pause between operations of not less than 20 s if not otherwise specified, in the detail specification or other applicable specification.

4.4 Environmental test conditions

These shall be standard conditions according to IEC 60068-1, unless otherwise stated in the detail specification.

This test may be required at low air pressure. In this case, the atmospheric conditions shall be in accordance with test M: Low air pressure of IEC 60068-2-13. The severity shall be as specified in the detail specification or other applicable specification.

4.5 Measurements

4.5.1 Initial measurements

Before testing according to 4.1 above, the following tests shall be performed:

- a) visual examination (IEC 60512-1-1);
- b) contact resistance – Millivolt level method (IEC 60512-2-1);
- c) insulation resistance (IEC 60512-3-1);
- d) voltage proof (IEC 60512-4-1);
- e) sealing (IEC 60068-2-13), if applicable.

4.5.2 Measurements during the test

Contact resistance may be monitored during the test according to Contact resistance – Specified current method (IEC 60512-2-2).

4.5.3 Final measurements

- a) Visual examination (IEC 60512-1-1).
- b) Contact resistance – Millivolt level method (IEC 60512-2-1).
- c) Insulation resistance (IEC 60512-3-1).
- d) Voltage proof (IEC 60512-4-1).
- e) Sealing (IEC 60068-2-13), if applicable.

The values and requirements shall be in accordance with those details referenced in Clause 5 below.

5 Details to be specified

When this test is required by the detail specification, the following details shall be given:

- a) Preparation of the specimen, type size and length of wire (cable) to be used.
- b) Any mounting of the specimen.
- c) Type of electrical load(s) e.g. resistance, capacitance and inductance.
- d) Voltage, a.c. or d.c. value, waveform type e.g. harmonic content and crest factor, impedance etc., as appropriate.

- e) Electrical current value.
- f) Atmospheric pressure, if other than standard;
- g) Number and duty cycle of engaging and separating cycles.
- h) Requirements for final measurements and/or allowable change from initial measurements.
- i) Any mechanical aids.
- j) If any contact lubricant shall be used and, if so, its specification.
- k) If low pressure testing is required.
- l) Any deviation from the standard test method.

iTeh STANDARD PREVIEW
(standards.iteh.ai)

[IEC 60512-9-3:2011](https://standards.iteh.ai/catalog/standards/sist/99231975-ce2d-4103-92a7-4b01bdf77486/iec-60512-9-3-2011)

<https://standards.iteh.ai/catalog/standards/sist/99231975-ce2d-4103-92a7-4b01bdf77486/iec-60512-9-3-2011>

Annex A (informative)

Typical circuit diagram

A.1 Examples of electrical circuit

NOTE These diagrams (Figures A.1 and A.2) show a single circuit; in the case of an 'n' way connector, there will be 'n' instances of test load components. The power source may be multiple of singular, with appropriate cables/conductors.

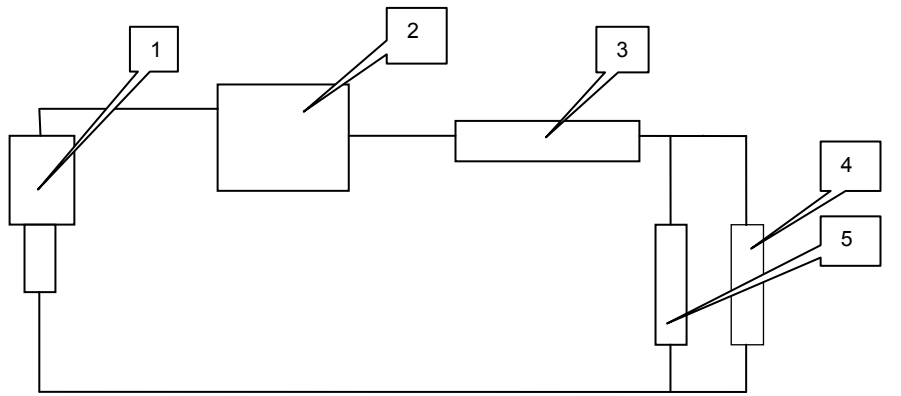

IEC 1367/11

Key

- 1 component under test
- 2 voltage source
- 3 inductor
- 4 resistor (variable)
- 5 capacitor

iTeh STANDARD PREVIEW
(standards.iteh.ai)

<https://standards.iteh.ai/catalog/standards/sist/99231975-ce2d-4103-92a7-4b01bdf77486/iec-60512-9-3-2011>

<https://standards.iteh.ai/catalog/standards/sist/99231975-ce2d-4103-92a7-4b01bdf77486/iec-60512-9-3-2011>

Figure A.1 – Example of circuit(s) – Diagrammatic

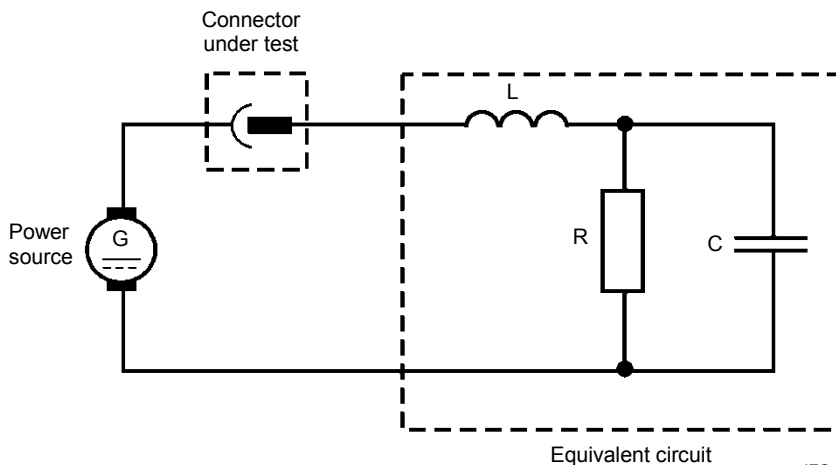

IEC 1368/11

Figure A.2 – Example of circuit(s) – Circuit diagram

A.2 Over-voltage during switching

For switched electrical inductive and capacitive loads, the use of a protection circuit, for example surge diode, varistor or RC combination, may be considered to avoid high switch over-voltage/current.