



Standard Test Method for Determining Micropore Volume and Zeolite Area of a Catalyst¹

This standard is issued under the fixed designation D 4365; the number immediately following the designation indicates the year of original adoption or, in the case of revision, the year of last revision. A number in parentheses indicates the year of last reapproval. A superscript epsilon (ϵ) indicates an editorial change since the last revision or reapproval.

1. Scope

1.1 This test method covers the determination of total surface area and mesopore area. From these results are calculated the zeolite area and micropore volume of a zeolite containing catalyst. The micropore volume is related to the percent zeolite in the catalyst. The zeolite area, a number related to the surface area within the zeolite pores, may also be calculated. Zeolite area, however, is difficult to interpret in physical terms because of the manner in which nitrogen molecules pack within the zeolite.

1.2 This standard does not purport to address all of the safety concerns, if any, associated with its use. It is the responsibility of the user of this standard to establish appropriate safety and health practices and determine the applicability of regulatory limitations prior to use. For specific precautionary statement, see Note 2.

2. Referenced Documents

2.1 ASTM Standards:

- D 3663 Test Method for Surface Area of Catalysts²
- D 3906 Test Method for Relative Zeolite Diffraction Intensities²
- E 177 Practice for Use of the Terms Precision and Bias in ASTM Test Methods³
- E 456 Terminology Relating to Quality and Statistics³
- E 691 Practice for Conducting an Interlaboratory Study to Determine the Precision of a Test Method³

3. Terminology

3.1 Definitions of Terms Specific to This Standard:

3.1.1 *mesopore area of a catalyst*—the area determined from the slope of the t-plot.

3.1.2 *micropore volume of the catalyst*—the pore volume in pores having radii less than 1 nm, usually associated with the zeolite portion of the catalyst, and determined from the intercept of the t-plot.

3.1.3 *surface area of a catalyst*—the total surface of the

catalyst pores. It is expressed in square metres per gram.

3.1.4 *zeolite area of a catalyst*—the difference between total surface area and mesopore area.

3.2 Symbols:

P_{H_1}	= initial helium pressure, torr
P_{H_2}	= helium pressure after equilibration, torr
S_B	= slope of BET plot, 11.7
I_B	= intercept of BET plot, 11.7
S_t	= slope of t-plot, 11.13
I_t	= intercept of t-plot, 11.13
T_{H1}	= temperature of manifold at initial helium pressure, °C
T_{H2}	= temperature of manifold after equilibration, °C
$T_x'(i)$	= extra volume bulb temperature, °C
$T_x(i)$	= extra volume bulb temperature, K
P_1	= initial N_2 pressure, torr
T_1	= manifold temperature at initial N_2 pressure, K
T_1'	= manifold temperature at initial N_2 pressure, °C
P_2	= pressure after equilibration, torr
T_2	= manifold temperature after equilibration, K
T_2'	= manifold temperature after equilibration, °C
P_0	= liquid nitrogen vapor pressure, torr
T_s	= liquid nitrogen temperature, K
X	= relative pressure, P_2/P_0
V_d	= volume of manifold, cm^3
V_x	= extra volume bulb, cm^3
V_s	= effective void volume, cm^3
\bar{W}	= weight of sample, g
W_1	= tare weight of sample tube, g
W_2	= weight of sample + tare weight of tube, g
V_{ds}	= volume of nitrogen in the dead-space, cm^3
V_1	= see 11.4.3
V_2	= see 11.4.4
V_t	= see 11.4.5
V_a	= see 11.4.7
V_m	= see 11.8
BET (i)	= see 11.4.8
$t(i)$	= see 11.10

4. Summary of Test Method

4.1 The volume of nitrogen gas adsorbed by the catalyst at liquid nitrogen temperature is measured at various low-pressure levels. This is done by measuring pressure differentials caused by introducing a fixed volume of nitrogen to the degassed catalyst in the test apparatus. This procedure is the

¹ This test method is under the jurisdiction of ASTM Committee D-32 on Catalysts and is the direct responsibility of Subcommittee D32.01 on Physical-Chemical Properties.

Current edition approved Aug. 15, 1995. Published October 1995. Originally published as D 4365 – 84. Last previous edition D 4365 – 85 (1994) ^{ϵ 1}.

² Annual Book of ASTM Standards, Vol 05.03.

³ Annual Book of ASTM Standards, Vol 14.02.

same as Test Method D 3663, that gives total surface area, but extends the pressure range to permit calculation of micropore volume and matrix surface area, by the t-plot method. Zeolite area is the difference between total area and matrix area.

5. Significance and Use

5.1 This gas adsorption method complements the X-ray procedure of Test Method D 3906. This test method will be useful to laboratories that do not have X-ray diffractometers. Each test method can be calibrated by use of an appropriate series of mechanical mixtures to provide what may be termed percent zeolite. If there is disorder in the zeolite, the adsorption method will yield higher values than the X-ray method. The reverse will be true if some zeolite pores (micropores) are blocked or filled.

6. Apparatus

6.1 A schematic diagram of the apparatus is shown in Fig. 1. It may be constructed of glass or of metal. It has the following features:

6.1.1 *Distribution Manifold*, having a volume between 20 and 35 cm³, (V_d), known to the nearest 0.05 cm³. This volume is defined as the volume between the stopcocks or valves and includes the pressure gage. It is preferred that this volume be thermostatted.

6.1.2 *Vacuum System*, capable of attaining pressures below 10⁻⁴ torr (1 torr = 133.3 Pa). This will include a vacuum gage (not shown in Fig. 1). Access to the distribution manifold is through the valve V.

6.1.3 *Constant-Volume Gage or Mercury Manometer*, capable of measurements to the nearest 0.1-torr sensitivity in the range from 0 to 1000 torr (1 torr = 133.3 Pa).

NOTE 1—See, for example, the article by Joy, A. S., *Vacuum*, Vol 3, 1953, p. 254 for a description of a constant-volume manometer.

6.1.4 *Valve (H)*, from the helium supply to the distribution manifold.

6.1.5 *Valve (N)*, from the nitrogen supply to the distribution manifold.

6.1.6 The connection between the sample tube and the S valve can be a standard-taper glass joint, a glass-to-glass seal, or a compression fitting.

6.1.7 *Extra Volume Bulb*, may be attached through valve EV. Its volume (V_x) should be 100 to 150 cm³, known to the nearest 0.05 cm³. V_x includes the volume of the stopcock bore in the glass apparatus. It is preferred that this volume be held at the same temperature as that of the distribution manifold.

NOTE 2—Modern commercial instruments automatically adjust the amounts dosed in order to produce data points at user-selected target pressures. Hence, the use of an EV bulb is optional. Some instruments can analyze multiple samples simultaneously and may use sample tubes with volumes outside of the range specified in this test method.

6.2 *Sample Tubes*, with volumes from 5 cm³ to 25 cm³ depending on the application. Markings should be placed on the sample tubes about 30 to 50 mm below the connectors to indicate the desired liquid nitrogen level.

6.3 *Heating Mantles or Small Furnaces*.

6.4 *Dewar Flasks*.

6.5 *Laboratory Balance*, with 0.1 mg (10⁻⁷ kg) sensitivity.

6.6 *Thermometer*, for measuring the temperature of the distribution manifold, $T_1'(i)$ or $T_2'(i)$, in degrees Celsius.

6.7 *Thermometer*, for measuring the temperature of the liquid nitrogen bath $T_s(i)$ in kelvins. This will preferably be a nitrogen vapor-pressure-thermometer that gives P_0 directly and has greater precision, or a resistance thermometer from which P_0 values may be derived.

6.8 *Thermometer*, for measuring the temperature of the EV bulb, $T_x'(i)$, if different from $T_1'(i)$ or $T_2'(i)$.

7. Reagents

7.1 *Purity of Reagents*—Reagent grade chemicals shall be used in all tests. Unless otherwise indicated, it is intended that all reagents shall conform to the specifications of the Committee on Analytical Reagents of the American Chemical Society, where such specifications are available.⁴ Other grades may be used, provided it is first ascertained that the reagent is of sufficiently high purity to permit its use without lessening the accuracy of the determination.

7.2 *Helium Gas*—A cylinder of helium gas at least 99.9 % pure.

7.3 *Liquid Nitrogen*, of such purity that P_0 is not more than 20 torr above barometric pressure. A fresh daily supply is recommended.

7.4 *Nitrogen Gas*—A cylinder of nitrogen gas at least 99.9 % pure.

8. Procedure—Sample Preparation and Degassing

8.1 Select a sample tube of the desired size. A 5-cm³ sample

⁴ *Reagent Chemicals, American Chemical Society Specifications*, American Chemical Society, Washington, DC. For suggestions on the testing of reagents not listed by the American Chemical Society, see *Analar Standards for Laboratory Chemicals*, BDH Ltd., Poole, Dorset, U.K., and the *United States Pharmacopeia and National Formulary*, U.S. Pharmacopeial Convention, Inc. (USPC), Rockville, MD.

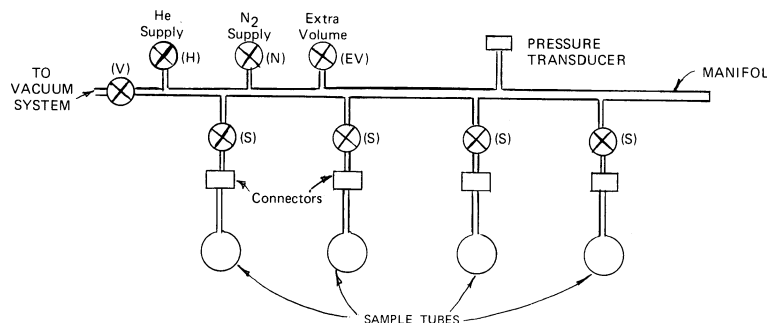

FIG. 1 Schematic Diagram of Surface Area Apparatus