

INTERNATIONAL  
STANDARD

**ISO**  
**12777-1**

First edition  
1994-12-15

---

---

**Methods of test for pallet joints —**

**Part 1:**

Determination of bending resistance of pallet  
nails, other dowel-type fasteners and staples

iTeh STANDARD PREVIEW  
(standards.iteh.ai)

*Méthodes d'essai des assemblages de palettes —*

*Partie 1. Détermination de la résistance à la flexion des clous et autres  
éléments de fixation de type cheville, et des clous cavaliers*

INTERNATIONAL

**ISO**



Reference number  
ISO 12777-1:1994(E)

## Foreword

ISO (the International Organization for Standardization) is a worldwide federation of national standards bodies (ISO member bodies). The work of preparing International Standards is normally carried out through ISO technical committees. Each member body interested in a subject for which a technical committee has been established has the right to be represented on that committee. International organizations, governmental and non-governmental, in liaison with ISO, also take part in the work. ISO collaborates closely with the International Electrotechnical Commission (IEC) on all matters of electrotechnical standardization.

Draft International Standards adopted by the technical committees are circulated to the member bodies for voting. Publication as an International Standard requires approval by at least 75 % of the member bodies casting a vote.

International Standard ISO 12777-1 was prepared by Technical Committee ISO/TC 51, *Pallets for unit load method of materials handling*.

ISO 12777 consists of the following parts, under the general title *Methods of test for pallet joints*:

- *Part 1: Determination of bending resistance of pallet nails, other dowel-type fasteners and staples*
- *Part 2: Testing of nails and staples for withdrawal and head pull-through resistance*
- *Part 3: Determination of bending strength*

## Introduction

In 1988 ISO/TC 51 requested ISO/TC 51/WG 2 to develop standard test methods for pallet joints. During the early meetings of WG 2 it became evident that the lack of International Standards on nail testing meant that fasteners (essential elements of pallet joints) could not be characterized sufficiently to enable worthwhile progress on full-joint testing. Although there were existing, or partially developed, nail testing principles, WG 2 considered that, in a practical situation where for quality control purposes or comparisons of nail quality reasonably accurate and rapid nail strength data were required, one, or both, of the two existing commercial nail testers was (were) better suited to the needs of pallet makers, pallet test laboratories and nail manufacturers.

Preliminary work by WG 2 led the manufacturers of both machines to make design modifications to improve accuracy. In November 1990, WG 2 appointed an *ad hoc* team of four members to evaluate the machines. The evaluation, carried out with the cooperation of the manufacturers/agents of each nail test machine, demonstrated that the technical requirements for nail test machines/principles were met by both machines.

<https://standards.iteh.ai/catalog/standards/sist/abdae9c-174e-4d2-8645-12777-1:1994>

The good correlation between the ultimate tensile strength of steel and the results of nail bending tests disappears once threads are rolled on to nails. Nail bending resistance is critical to the performance of a nail and, for this reason, the bending resistance of finished nails is the recommended method for specifying pallet nails and staples.

Users should not automatically specify the highest grade of nail in a pallet design, any more than they would automatically specify the strongest available wood species. In general, it is only to improve the performance of a particular joint that is proving a weak link in a pallet design, or to build in a longer life, etc., that nail upgrading would take place. There are also many instances where a nail with a lower performance would be the best choice, such as in a pallet-mat subassembly constructed with clinched nails.

## iTeh STANDARD PREVIEW

This page intentionally left blank  
(standards.iteh.ai)

[ISO 12777-1:1994](#)

<https://standards.iteh.ai/catalog/standards/sist/abdae9c-174e-4df2-8645-787c963b2856/iso-12777-1-1994>

# Methods of test for pallet joints —

## Part 1:

### Determination of bending resistance of pallet nails, other dowel-type fasteners and staples

#### 1 Scope

This part of ISO 12777 describes test methods for the determination of the bending resistance of pallet nails, staples and other dowel-type fasteners.

It includes tests for the

- a) ultimate strength in static bending (three- and four-point loading methods),
- b) impact bend resistance (three-point loading method).

These test methods apply to all types of nails, including loose, collated or coil nails, up to 6 mm in diameter (round, square, fluted, twisted, plain or threaded) and may also be suitable for other fasteners such as staples.

#### 2 Definition

For the purposes of this part of ISO 12777, the following definition applies.

##### 2.1 bending resistance

(1) (primary static method): The ultimate strength determined in bending configuration using a three- or four-point loading method. It is measured as torque in newton metres.

(2) (supplementary impact method): The impact bend resistance under the application of a given load. It is measured in degrees as an angle of deformation.

#### 3 Symbols

$F$	Applied force, in newtons
$F_R$	Force of reaction, in newtons
$I$	Impact load (impulse), in newton seconds
$M$	Applied torque, in newton metres
$M_R$	Opposing torque, in newton metres
$l$	Nail or staple length, in millimetres, under bending stress (dimension B to C in figures 1 and 3)
$L$	Effective length, in millimetres, of load actuator
$\alpha$	Angular movement, in degrees
$\beta$	Angle of deformation, in degrees

#### 4 Static bend tests (primary methods)

##### 4.1 Three-point loading method

###### 4.1.1 Principle

A nail, staple or other dowel-type fastener is clamped in such a way as to resist bending at two points A and B (see figure 1). A force is then applied to the unclamped portion of the nail at a set point C, using a pivoted bending actuator to which torque is applied. The maximum torque applied is recorded.

**4.1.2 Apparatus<sup>1)</sup>**

The equipment shall have an accuracy and a repeatability of  $\pm 4\%$ .

A typical test apparatus is shown in figure 2; it comprises the following items.

**4.1.2.1 Clamping device**, with the front edge (point B in figure 1) having a radius of 2 mm.

**4.1.2.2 Bending actuators**, interchangeable, pivoted, each fitted with two bending arms, to provide a range of different mechanical advantages when applying force to the nail.

**4.1.2.3 Framework** to position the actuator in relation to the clamping device.

**4.1.2.4 Means of applying torque to the actuator**, e.g. a torque wrench, and of recording the maximum torque applied.

NOTE 1 A plain shank calibration nail of known characteristics may assist in ensuring that the test apparatus is operating correctly. However this is not an alternative to traceable calibration, with which it may be combined.

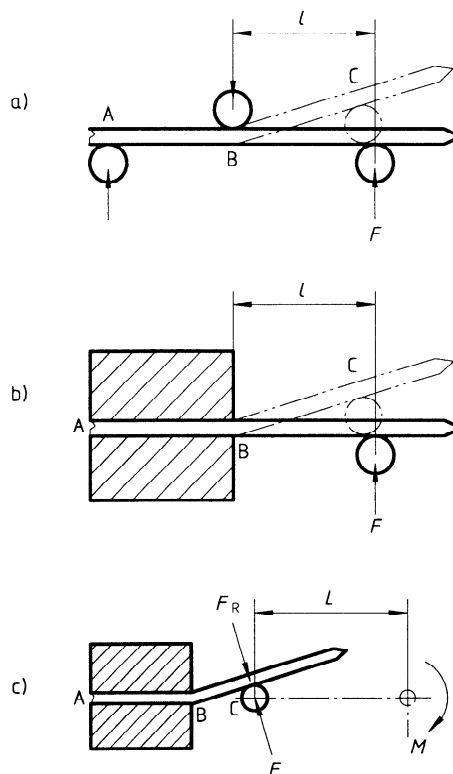

Applied torque  $M = F_R K$

STANDARD PREVIEW  
(standards.iteh.ai)

**Figure 1 — Principle of the three-point loading static bend test showing the application of force  $F$**

**4.1.3 Procedure**

**4.1.3.1** Clamp the nail under test in the position required by the particular apparatus in use.

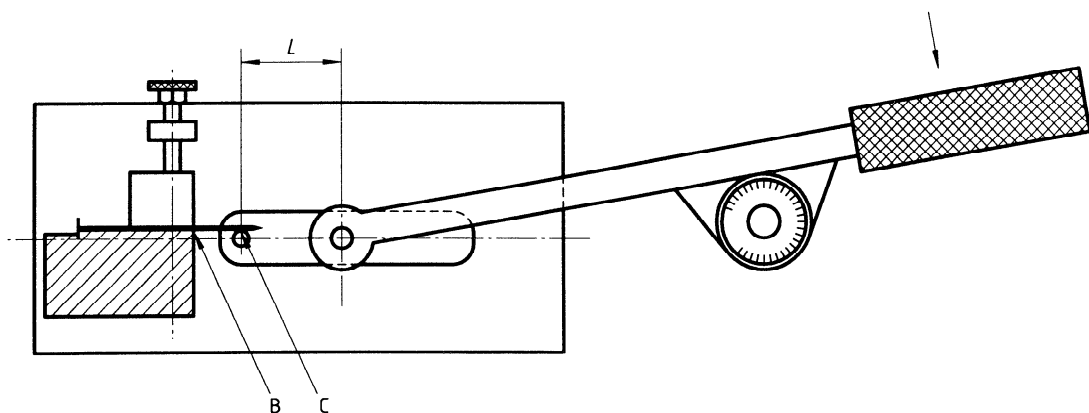

**Figure 2 — Typical test apparatus — Three-point loading static bend test**

1) Robiment Mk II is the tradename of a suitable test apparatus supplied by Rockhi GmbH, Hilchenbach, Germany. This information is given for the convenience of users of this part of ISO 12777 and does not constitute an endorsement by ISO of this product. Equivalent products may be used if they can be shown to lead to the same results.

**4.1.3.2** Select the appropriate bending actuator (4.1.2.2) for the type and diameter of the nail under test.

**4.1.3.3** Using the torque wrench or other suitable means (4.1.2.4), slowly apply the bending force to the nail until it bends. Record the maximum torque applied.

In the case of square nails, separate tests should be carried out to determine bending resistance across the flats and across the corners.

**4.1.3.4** Convert the maximum torque reading into newton metres by applying the factor appropriate to the bending actuator employed.

**4.1.4 Expression of results**

Express the results as the maximum applied torque in newton metres (N·m).

**4.1.5 Test report**

The test report shall include the following information:

- a) reference to this part of ISO 12777;
- b) the number of nails (fasteners) tested;
- c) a description of the nails tested, including shank diameter ( $d$ ), profile of threaded portion, shape of staple legs, etc. and, in the case of square nails, the direction of test;
- d) type of apparatus used;
- e) length of nail under bending stress ( $l$ ), in millimetres;
- f) effective length of the actuator ( $L$ ), in millimetres;
- g) maximum torque applied, in newton metres;
- h) date of test;
- i) name of the organization carrying out the test;
- j) signature of the person responsible for the test.

**4.2 Four-point loading method**

**4.2.1 Principle**

A nail is positioned in two locating devices and a moment  $M$  is applied to the block which forms the second locating device, causing the nail to bend. The

force involved is recorded together with the angular movement of the block (see figure 3).

**4.2.2 Apparatus**

The equipment shall have an accuracy and a repeatability of  $\pm 4\%$ .

The apparatus comprises the following items.

**4.2.2.1 Locating device**, loose-fitting, which only makes firm contact with the nail under test at both points A and B (see figure 3) as load is applied by a second locating device via moment  $M$ .

**4.2.2.2 Second locating device**, loose-fitting, in the form of a block, which only makes firm contact at both points C and D (see figure 3) when it is rotated via moment  $M$  and the load is resisted by the first locating device.

**4.2.2.3 Synchronized motor worm-drive**, turning anticlockwise, to apply moment  $M$ .

**4.2.2.4 Means of measuring force  $F$**  at the end of a floating beam of 1 m length, fixed to location points A and B.

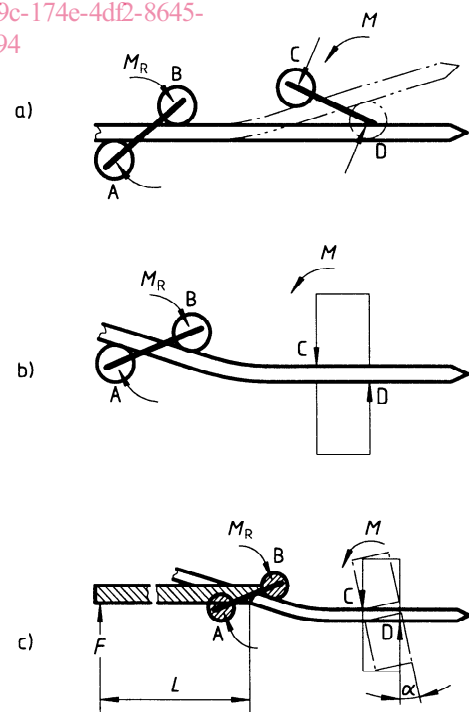

Applied torque  $M = F L$

**Figure 3 — Principle of the four-point loading static bend test showing the application of force  $F$**

**4.2.2.5 Plotter**, to record the force  $F$  against a time base, enabling a plot of  $F$  against  $\alpha$  (the angular movement of the block) to be produced.

NOTE 2 A plain shank calibration nail of known characteristics may assist in ensuring that the test apparatus is operating correctly. However this is not an alternative to traceable calibration, with which it may be combined.

### 4.2.3 Procedure

**4.2.3.1** Position the nail under test in the locating devices (4.2.2.1 and 4.2.2.2).

**4.2.3.2** Start the motor (4.2.2.3) and allow the nail to bend. Monitor the force recorded and stop the test once the maximum force applied has been clearly identified.

In the case of square nails, separate tests should be carried out to determine bending resistance across the flats and across the corners.

### 4.2.4 Expression of results

Express the results as the maximum torque in newton metres.

### 4.2.5 Test report

The test report shall include the following information:

- a) reference to this part of ISO 12777;
- b) the number of nails (fasteners) tested;
- c) a description of the nails tested, including shank diameter ( $d$ ), profile of threaded portion, shape of staple legs, etc. and, in the case of square nails, the direction of test;
- d) maximum torque applied, in newton metres;
- e) angle of movement ( $\alpha$ ) at which the maximum torque was recorded;
- f) date of test;
- g) name of the organization carrying out the test;
- h) signature of the person responsible for the test.

2) Mibant model No. TE 154 is the tradename of a suitable test apparatus supplied by Duofast, Franklin Park, IL 60131, USA. This information is given for the convenience of users of this part of ISO 12777 and does not constitute an endorsement by ISO of the product named. Equivalent products may be used if they can be shown to lead to the same results.

## 5 Impact bend test (supplementary method)

### 5.1 Principle

A nail (or other dowel-type fastener) is clamped at  $10^\circ$  to the horizontal, with the head end of the nail protruding for a set distance.

A standard weightpiece is then dropped from a fixed height on to the nail head. Following the impact, the angle of deformation ( $\beta$ ) is measured (see figure 4).

### 5.2 Apparatus<sup>2)</sup>

The equipment shall have an accuracy and a repeatability of  $\pm 4\%$ .

A typical test apparatus is shown in figure 5; it comprises the following items.

**5.2.1 Baseplate**, fitted with built-in adjusters to ensure that it is horizontal, to which are fixed the other components.

**5.2.2 Fixed anvil**, with top clamping device which holds the nail at an angle of  $10^\circ$  relative to the baseplate.

**5.2.3 Drop shaft**, set at  $90^\circ$  to the baseplate, at a fixed distance from the anvil, on which the test weightpiece can be positioned and held at a set distance above the nail under test, with a means of releasing the weightpiece.

**5.2.4 Circular weightpiece**, with a central hole such that the weightpiece slides with negligible friction up and down the drop shaft.

The diameter of the weightpiece shall be such that, when the head of the nail under test is positioned 11,9 mm from the anvil, the point of impact on the underside of the falling weight shall be 1,6 mm from the edge of the weight.

**5.2.5 Means of determining the angle of deformation,  $\beta$ .**

### 5.3 Procedure

**5.3.1** Clamp the nail under test with its head positioned towards the drop shaft (5.2.3), at a distance of 11,9 mm from the anvil (5.2.2).

iTeh STANDARD PREVIEW  
(standards.iteh.ai)

ISO 12777-1:1994  
<https://standards.iteh.ai/catalog/standards/sist/6049c116-4d21-4843-787c963b2856/iso-12777-1-1994>



**5.3.2** Select the appropriate weightpiece<sup>3)</sup> (5.2.4) and position it on the drop shaft to give a drop height of  $305 \text{ mm} \pm 3 \text{ mm}$ . Release the weightpiece and allow it to strike the nail head. Raise the weightpiece, then measure and record the angle of deformation (see figure 6).

In the case of square nails, separate tests should be carried out across the flats and across the corners to determine the angle of deformation.

#### 5.4 Expression of results

Express the results as the angle of deformation in degrees.

#### 5.5 Test report

The test report shall include the following information:

- reference to this part of ISO 12777;
- the number of nails (fasteners) tested;
- description of the nails tested, including shank diameter ( $d$ ), profile of threaded portion, shape of staple legs, etc. and, in the case of square nails, the direction of test;
- type of apparatus used;
- mass of the weightpiece used, in kilograms, and the drop height, in millimetres;
- length of nail ( $l$ ), in millimetres, protruding from the anvil;
- angle of deformation ( $\beta$ ) of each nail tested;
- date of test;
- name of organization carrying out the test;
- signature of the person responsible for the test.

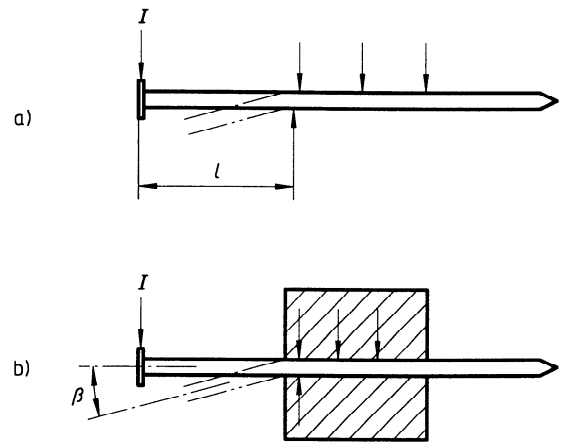

**Figure 4 — Principle of the three-point impact method by impact load (impulse)  $I$ , showing angle of deformation  $\beta$**

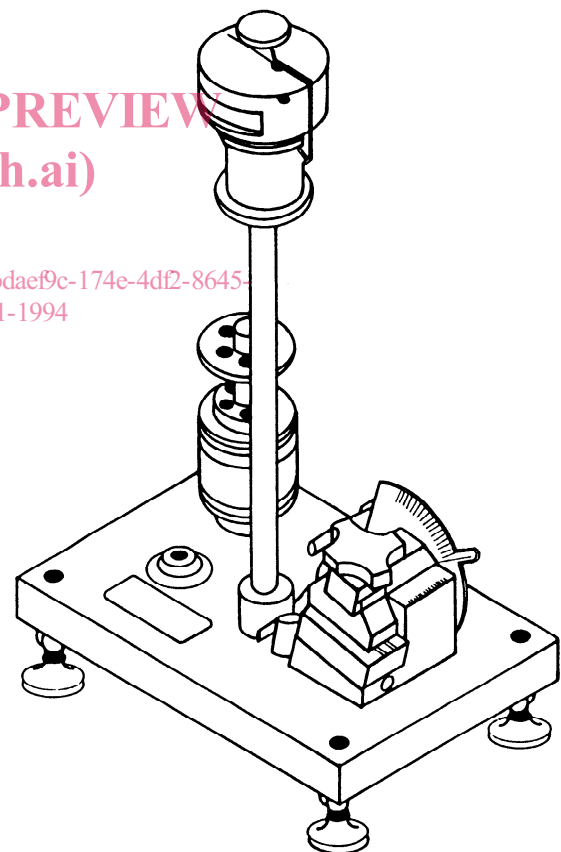

**Figure 5 — Typical test apparatus — Three-point impact method**

<sup>3)</sup> A test weightpiece having a mass of 1,58 kg is suitable for general testing.