

INTERNATIONAL STANDARD

ISO
9455-11

First edition
1991-12-15

Soft soldering fluxes — Test methods —

Part 11:

Solubility of flux residues

iTeh STANDARD PREVIEW

(standards.iteh.ai)

Flux de brasage tendre — Méthodes d'essai —

Partie 11: Solubilité des résidus de flux

ISO 9455-11:1991

<https://standards.iteh.ai/catalog/standards/sist/a4bba6b6-50be-485f-bac1-d6446a97e8ba/iso-9455-11-1991>



Reference number
ISO 9455-11:1991(E)

Foreword

ISO (the International Organization for Standardization) is a worldwide federation of national standards bodies (ISO member bodies). The work of preparing International Standards is normally carried out through ISO technical committees. Each member body interested in a subject for which a technical committee has been established has the right to be represented on that committee. International organizations, governmental and non-governmental, in liaison with ISO, also take part in the work. ISO collaborates closely with the International Electrotechnical Commission (IEC) on all matters of electrotechnical standardization.

Draft International Standards adopted by the technical committees are circulated to the member bodies for voting. Publication as an International Standard requires approval by at least 75 % of the member bodies casting a vote.

International Standard ISO 9455-11 was prepared by Technical Committee ISO/TC 44, *Welding and allied processes*, Sub-Committee SC 12, *Soldering and brazing materials*.

ISO 9455 consists of the following parts, under the general title *Soft soldering fluxes — Test methods*:

- Part 1: *Determination of non-volatile matter, gravimetric method*
- Part 2: *Determination of non-volatile matter, ebulliometric method*
- Part 3: *Determination of acid value, potentiometric and visual titration methods*
- Part 5: *Copper mirror test*
- Part 6: *Determination of halide content*
- Part 8: *Determination of zinc content*
- Part 9: *Determination of ammonia content*
- Part 10: *Flux efficacy tests, solder spread method*
- Part 11: *Solubility of flux residues*
- Part 12: *Steel tube corrosion test*

© ISO 1991

All rights reserved. No part of this publication may be reproduced or utilized in any form or by any means, electronic or mechanical, including photocopying and microfilm, without permission in writing from the publisher.

International Organization for Standardization
Case Postale 56 • CH-1211 Genève 20 • Switzerland

Printed in Switzerland

- *Part 13: Determination of flux spattering*
- *Part 14: Assessment of tackiness of flux residues*
- *Part 15: Copper corrosion test*
- *Part 16: Flux efficacy tests, wetting balance method*
- *Part 17: Determination of surface insulation resistance of flux residues (Comb test)*

iTeh STANDARD PREVIEW
(standards.iteh.ai)

[ISO 9455-11:1991](https://standards.iteh.ai/catalog/standards/sist/a4bbafb6-50be-485f-bac1-d6446a97e8ba/iso-9455-11-1991)

<https://standards.iteh.ai/catalog/standards/sist/a4bbafb6-50be-485f-bac1-d6446a97e8ba/iso-9455-11-1991>

iTeh STANDARD PREVIEW
(standards.iteh.ai)

This page intentionally left blank

[ISO 9455-11:1991](#)

<https://standards.iteh.ai/catalog/standards/sist/a4bbafb6-50be-485f-bac1-d6446a97e8ba/iso-9455-11-1991>

Soft soldering fluxes — Test methods —

Part 11: Solubility of flux residues

1 Scope

This part of ISO 9455 specifies a qualitative method for assessing the solubility of flux residues in a selected solvent. The method is applicable to all fluxes of Type 1, as defined in ISO 9454-1.

NOTE 1 This test gives no assurance that post-cleaning residues, which may be present in sufficiently small amounts to pass the test, will not be detrimental to the soldered assembly in the long term.

2 Normative references

The following standards contain provisions which, through reference in this text, constitute provisions of this part of ISO 9455. At the time of publication, the editions indicated were valid. All standards are subject to revision, and parties to agreements based on this part of ISO 9455 are encouraged to investigate the possibility of applying the most recent editions of the standards indicated below. Members of IEC and ISO maintain registers of currently valid International Standards.

ISO 1634-1:1987, *Wrought copper and copper alloy plate, sheet and strip — Part 1: Technical conditions of delivery for plate, sheet and strip for general purposes.*

ISO 9454-1:1990, *Soft soldering fluxes — Classification and requirements — Part 1: Classification, labelling and packaging.*

3 Principle

A brass test plate is fluxed, heated to soldering temperature and, after conditioning, is immersed in the selected solvent to dissolve the flux residue. The

effectiveness of the flux residue removal is indicated by the presence of a current flowing across the junction between the cleaned area and an electrical probe tip.

4 Reagents and materials

4.1 General

In the test use only reagents of recognized analytical quality and only distilled, or deionized, water.

4.2 Acid cleaning solution

Add cautiously, with stirring, 75 ml of sulfuric acid (ρ 1,84 g/ml) to 210 ml of water and mix. Cool, add 15 ml of nitric acid (ρ 1,42 g/ml) and mix the solution thoroughly.

4.3 Solvent

This is the solvent selected for the flux residue removal as recommended by the flux manufacturer or supplier.

NOTE 2 The solvent to be used will vary with the flux composition.

4.4 Industrial methylated spirits.

4.5 Oil crayon.

4.6 **Brass test plates**, each 60 mm × 60 mm, cut from 0,5 mm thick brass sheet complying with ISO 1634-1, alloy CuZn 37, condition HA.

A 3 mm deep depression shall be formed in the centre of each test plate by means of a 20 mm diameter steel ball.

5 Apparatus

Usual laboratory apparatus and, in particular, the following.

5.1 Solder bath, containing not less than 4 kg of solder alloy, having a depth when molten of not less than 25 mm and capable of being maintained at a temperature of (300 ± 10) °C.

5.2 Temperature/humidity oven, capable of maintaining a temperature of (23 ± 2) °C and a relative humidity (50 ± 5) %.

5.3 Power source, 6 V d.c.

5.4 Variable resistor, 0 to 100 Ω.

5.5 Milliammeter, 100 mA d.c.

5.6 Test probe, consisting of a copper rod, 4 mm diameter × 50 mm long, with a palladium/silver tip 4 mm radius, fitting into a guide sleeve of non-conducting material (see figure 1). The probe shall be capable of pressing freely, i.e. under its own weight, on to the surface of the brass test plate (4.6).

6 Procedure

Carry out the following procedure, in triplicate, on the flux sample.

Clean two brass test plates (4.6) by immersion for 15 s in the acid cleaning solution (4.2). Rinse the test plates under running water, then in industrial methylated spirits (4.4) and dry with warm air.

Draw a 30 mm diameter circle round the depression on each test plate with the oil crayon (4.5), in order to restrict the spread of the flux during the test.

Place 0,1 ml of the liquid flux sample, or 0,05 g of the solid or paste flux sample in the depression of both test plates.

Float one of the test plates for 5 s on the surface of the solder bath (5.1), which is maintained at (300 ± 10) °C. Remove the test plate (designated "plate A") and cool to room temperature. The other test plate (designated "plate B"), which is used as a control, is not subjected to this heating stage. Condition both the test plates in the humidity oven (5.2) at (23 ± 2) °C and (50 ± 5) % relative humidity, for 24 h.

Within 1 h of removing the test plates from the oven, immerse them in the selected solvent (4.3) for either a) 1 min or b) 10 min. Dip the test plates in clean solvent (4.3) for 2 s and then in industrial methylated spirits (4.4) for 2 s. Dry the test plates in warm air.

Condition the test plates again at (23 ± 2) °C and (50 ± 5) % relative humidity in the oven (5.2) for 24 h.

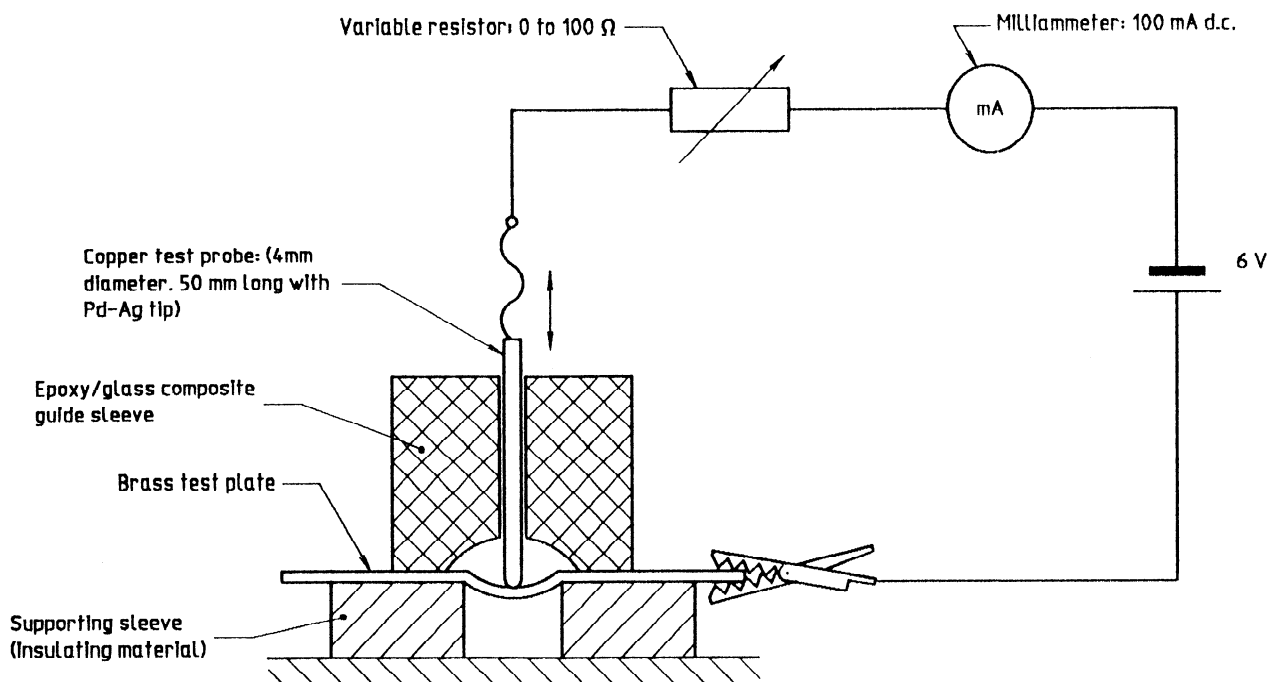

Figure 1 — Test apparatus for efficiency of flux residue removal

Connect the control test plate ("plate B") into the circuit, as shown in figure 1. Place the test probe tip in the centre of the depression in the test plate, allowing it to rest under its own weight. Adjust the variable resistor to give full-scale deflection on the milliammeter.

Remove the control test plate from the circuit and replace it with the other test plate ("plate A") and observe the nature of the milliammeter reading.

7 Assessment of results

If the heated and cleaned test plate ("plate A"), when connected into the circuit, gives a steady, full-scale reading on the milliammeter, then the flux residue has been efficiently removed and the flux is deemed to have passed the test using the selected solvent.

However, if an unsteady reading, or a current reading less than full-scale is obtained, then the flux is

deemed to have failed the test using the selected solvent.

8 Test report

The test report shall include the following information:

- a) identification of the test sample;
- b) test method used (i.e. reference to this part of ISO 9455);
- c) solvent selected for the test (see 4.3);
- d) whether the test plate was immersed in the solvent for 1 min or 10 min (see clause 6);
- e) the results obtained;
- f) any unusual features noted during the test;
- g) details of any operation not included in this part of ISO 9455, or regarded as optional.

iTeh STANDARD PREVIEW (standards.iteh.ai)

[ISO 9455-11:1991](https://standards.iteh.ai/catalog/standards/sist/a4bbafb6-50be-485f-bac1-d6446a97e8ba/iso-9455-11-1991)

<https://standards.iteh.ai/catalog/standards/sist/a4bbafb6-50be-485f-bac1-d6446a97e8ba/iso-9455-11-1991>

iTeh STANDARD PREVIEW
(standards.iteh.ai)

ISO 9455-11:1991

<https://standards.iteh.ai/catalog/standards/sist/a4bbafb6-50be-485f-bac1-d6446a97e8ba/iso-9455-11-1991>

UDC 621.791.35.048:543.72

Descriptors: soldering, soldering fluxes, chemical residues, tests, solubility tests.

Price based on 3 pages
