



SLOVENSKI STANDARD
SIST EN 3542:2001
01-januar-2001

Aerospace series - Inserts, screw thread, helical coil, self-locking, in heat resisting nickel base alloy NI-PH2801 (Inconel X750)

Aerospace series - Inserts, screw thread, helical coil, self-locking, in heat resisting nickel base alloy NI-PH2801 (Inconel X750)

Luft- und Raumfahrt - Draht-Gewindeeinsätze, selbstsichernd, aus hochwarmfester Nickelbasislegierung NI-PH2801 (Inconel X750)

Série aérospatiale - Filets rapportés, à freinage interne, en alliage résistant a chaud a base de nickel NI-PH2801 (Inconel X750)

<https://standards.iteh.ai/catalog/standards/sist/2cd57868-0114-4c5e-85fa-ed82fda53227/sist-en-3542-2001>

Ta slovenski standard je istoveten z: EN 3542:1998

ICS:

49.030.30 Matice Nuts

SIST EN 3542:2001 en

iTeh STANDARD PREVIEW
(standards.iteh.ai)

SIST EN 3542:2001

<https://standards.iteh.ai/catalog/standards/sist/2cd57868-0114-4c5e-85fa-ed82fda53227/sist-en-3542-2001>

EUROPEAN STANDARD

EN 3542

NORME EUROPÉENNE

EUROPÄISCHE NORM

May 1998

ICS 49.030.30

Descriptors: aircraft industry, screw thread, self-locking screw thread, nickel alloy, heat resistant material, characteristic, dimension, designation, marking

English version

Aerospace series - Inserts, screw thread, helical coil, self-locking, in heat resisting nickel base alloy NI-PH2801 (Inconel X750)

Série aérospatiale - Filets rapportés, à freinage interne, en alliage résistant à chaud à base de nickel NI-PH2801 (Inconel X750)

Luft- und Raumfahrt - Draht-Gewindeeinsätze, selbstsichernd, aus hochwarmfester Nickelbasislegierung NI-PH2801 (Inconel X750)

This European Standard was approved by CEN on 23 February 1998.

CEN members are bound to comply with the CEN/CENELEC Internal Regulations which stipulate the conditions for giving this European Standard the status of a national standard without any alteration. Up-to-date lists and bibliographical references concerning such national standards may be obtained on application to the Central Secretariat or to any CEN member.

This European Standard exists in three official versions (English, French, German). A version in any other language made by translation under the responsibility of a CEN member into its own language and notified to the Central Secretariat has the same status as the official versions.

<https://standards.iteh.ai/catalog/standards/sist/2cd57868-0114-4c5e-85fa-cd876a3277/cen-en-3542-2001>

CEN members are the national standards bodies of Austria, Belgium, Czech Republic, Denmark, Finland, France, Germany, Greece, Iceland, Ireland, Italy, Luxembourg, Netherlands, Norway, Portugal, Spain, Sweden, Switzerland and United Kingdom.



EUROPEAN COMMITTEE FOR STANDARDIZATION
COMITÉ EUROPÉEN DE NORMALISATION
EUROPÄISCHES KOMITEE FÜR NORMUNG

Central Secretariat: rue de Stassart, 36 B-1050 Brussels

Foreword

This European Standard has been prepared by the European Association of Aerospace Manufacturers (AECMA).

After inquiries and votes carried out in accordance with the rules of this Association, this Standard has received the approval of the National Associations and the Official Services of the member countries of AECMA, prior to its presentation to CEN.

This European Standard shall be given the status of a national standard, either by publication of an identical text or by endorsement, at the latest by November 1998, and conflicting national standards shall be withdrawn at the latest by November 1998.

<https://standards.iteh.ai/catalog/standards/sist/2cd57868-0114-4c5e-85fa-418888888888>

According to the CEN/CENELEC Internal Regulations, the national standards organizations of the following countries are bound to implement this European Standard: Austria, Belgium, Czech Republic, Denmark, Finland, France, Germany, Greece, Iceland, Ireland, Italy, Luxembourg, Netherlands, Norway, Portugal, Spain, Sweden, Switzerland and the United Kingdom.

REPUBLIC OF CROATIA
INSTITUT ZA STANDARDIZACIJU
IZ OBLASTI MEHANIKE
ANALIZI
..... TC18
.....



0 Introduction

For design and assembly procedures see EN 3044 and EN 2945.

1 Scope

This standard specifies the characteristics of self-locking, helical coil, screw thread inserts in NI-PH2801, for aerospace applications.

Maximum test temperature : 550 °C

2 Normative references

This European Standard incorporates by dated or undated reference provisions from other publications. These normative references are cited at the appropriate places in the text and the publications are listed hereafter. For dated references, subsequent amendments to or revisions of any of these publications apply to this European Standard only when incorporated in it by amendment or revision. For undated references the latest edition of the publication referred to applies.

ISO 5855-2	Aerospace - MJ threads - Part 2: Limit dimensions for bolts and nuts
EN 2424	Aerospace series - Marking of aerospace products
EN 2943	Aerospace series - Inserts, screw thread, helical coil, self-locking - Technical specification
EN 2945	Aerospace series - Inserts, screw thread, helical coil, self-locking - Assembly procedure https://standards.iteh.ai/catalog/standards/sist/2cd57868-0114-4c5e-85fa-
EN 3018	Aerospace series - Heat resisting alloy NI-PH2801 (NiCr16Fe7Ti3Nb1Al1) - Consumable electrode remelted - Cold drawn wire for the manufacture of thread inserts - $D \leq 3$ mm ¹⁾
EN 3044	Aerospace series - Installation holes and procedures for inserts, screw thread, helical coil, self-locking - Design standard

3 Required characteristics

3.1 Configuration - Dimensions - Tolerances - Masses

See figure 1 and tables 1 and 2. Dimensions and tolerances are in millimetres.

3.2 Material

EN 3018

3.3 Material identification

Colour: yellow

No chlorine-based constituents permitted in the colour identification product

1) Published as AECMA Prestandard at the date of publication of this standard

$$R_a 1,6 / \left[R_a 0,8 / \right]$$

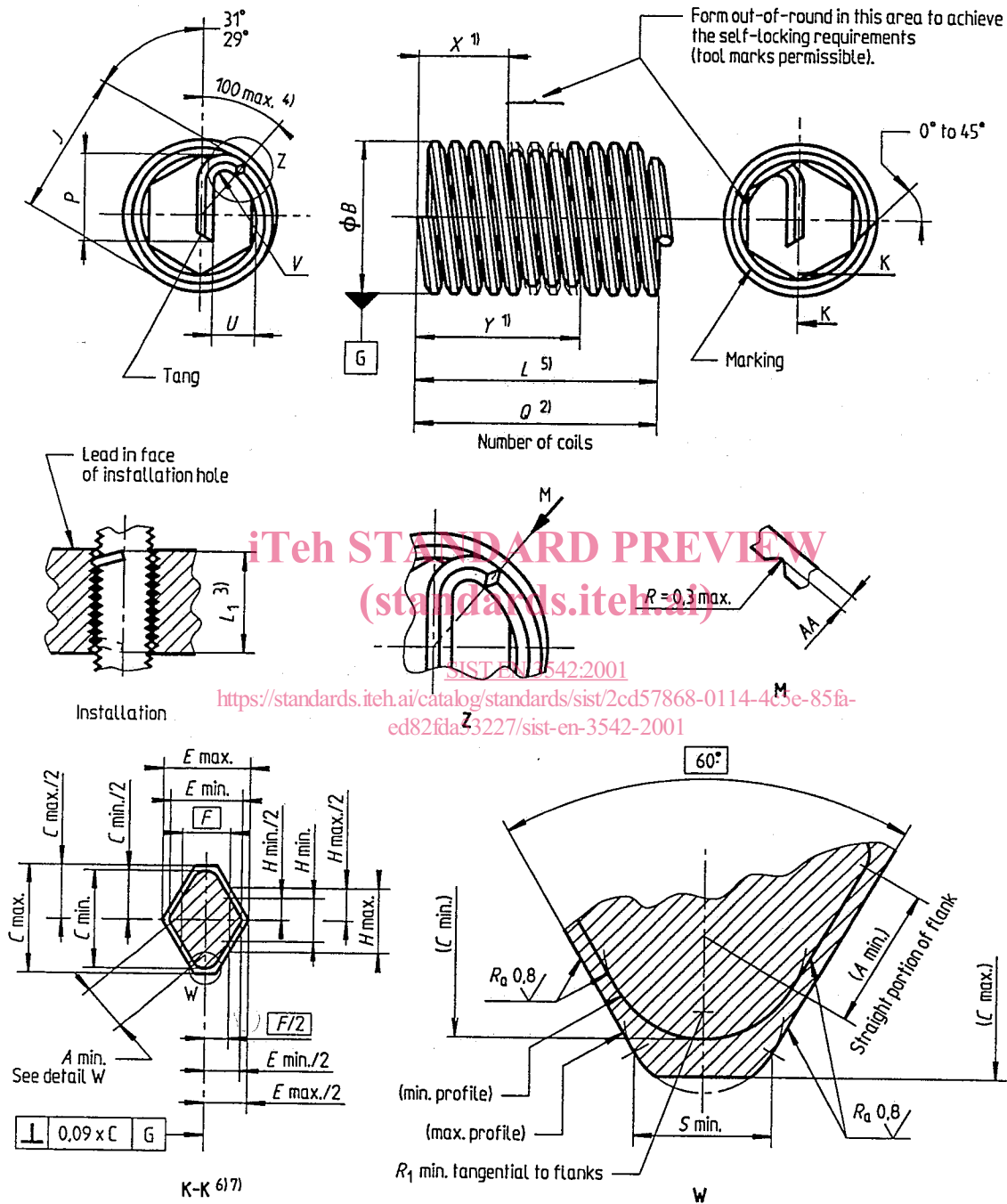

Details of form not stated are left to the manufacturer's discretion.

- 1) Locking feature shall be in the zone Y max. - X min. It shall take place on at least two coils separated by a plain coil, except in the case of inserts of diameters 4, 5 and 6 and a nominal length of $1,25 D$ where the plain coil may be omitted.
- 2) The number of coils is counted from the notch.
- 3) Length of fitted insert to notch
- 4) The notch shall be on the upper face of the first coil behind the tangent point of the tang radius.
- 5) The nominal length L is a reference. It is equal to the basic length of the thread insert.
- 6) Dimensions after coiling, corresponding to an insert fitted in an installation hole to EN 3044
- 7) Section K-K is perpendicular to the helical axis.

Figure 1

Table 1

Diameter code	Thread ¹⁾ (Associated bolt)	A		B		C		E		F	H	
		min.		+ 0,55 0		max.	min.	max.	min.		max.	min.
040	MJ4x0,7	0,163		5,05		0,758	0,683	0,612	0,51	0,35	0,455	0,4445
050	MJ5x0,8	0,209		6,25		0,866	0,775	0,7	0,598	0,4	0,52	0,5085
060	MJ6x1	0,267		7,4		1,083	0,975	0,875	0,748	0,5	0,65	0,637
070	MJ7x1			8,65								
080	MJ8x1			9,7								
100	MJ10x1,25	0,415		12,1		1,353	1,251	1,094	0,967	0,625	0,812	0,799

(concluded)

Diameter code	J		P		R ₁	S	U		V	AA	
	max.	min.	max.	min.	min.	min.	max.	min.	max.	max.	min.
040	5,6	4,9	3,55	2,5	0,126	0,219	1,67	1,02	0,45	0,34	0,31
050	6,8	6,1	4,55	3,15	1,144	0,25	2,09	1,41	0,6	0,37	0,34
060	7,95	7,25	4,85	3,7			2,55	1,65		0,75	0,5
070	9,2	8,4	5,5	4,3	0,18	0,312	3,1	2,09			
080	10	9,2	6,5	4,75			3,88	2,27			
100	12,3	11,5	8	5,5	0,226	0,391	4,77	2,86		0,6	0,55

1) In accordance with ISO 5855-2

Table 2

Diameter code	Thread ¹⁾ (Associated bolt)	L		L ₁		X ²⁾		Y ²⁾		Q		Mass ≈ kg/1 000 pieces	
		nom.		+ 0,25 0		min.		max.		Number of coils ± 0,25			
		1,25 D	1,5 D	1,25 D	1,5 D	1,25 D	1,5 D	1,25 D	1,5 D	1,25 D	1,5 D	1,25 D	1,5 D
040	MJ4x0,7	5	6	4,47	5,47	1,5	1,5	3	3,7	4,9	6,1	0,19	0,23
050	MJ5x0,8	6,3	7,5	5,65	6,9	2	2	3,8	4,2	5,5	6,9	0,34	0,42
060	MJ6x1	7,5	9	6,75	8,25	2,3	2,3	4,5	5,5	5,4	6,8	0,61	0,75
070	MJ7x1	8,8	10,5	8	9,75	2,5	2,5	5,5	6,5	6,5	8	0,84	1,03
080	MJ8x1	10	12	9,25	11,25	3	3	7	7	7,5	9,4	1,12	1,38
100	MJ10x1,25	12,5	15	11,56	14,06	3,5	3,5	9	9	7,6	9,5	2,19	2,68

1) In accordance with ISO 5855-2

2) X and Y dimensions apply after installation of the thread insert.

4 Designation

EXAMPLE:

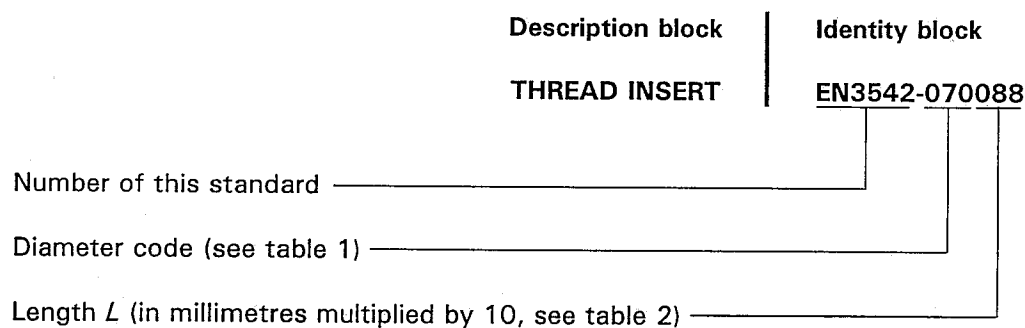

NOTE: If necessary, the code I9005 shall be placed between the description block and the identity block.

5 Marking

EN 2424

- style G;
- additionally style F permitted, as indicated on figure 1.

iTeh STANDARD PREVIEW
(standards.iteh.ai)
SIST EN 3542:2001
<https://standards.iteh.ai/catalog/standards/sist/2cd57868-0114-4c5e-85fa-ed82fda53227/sist-en-3542-2001>

6 Technical specification

EN 2943