

# INTERNATIONAL STANDARD

# ISO 9528

First edition  
1989-12-01

---

---

## Aerospace — Standard-weight polytetrafluoroethylene (PTFE) hose assemblies, classification 204 °C/21 000 kPa — Procurement specification

### iTeh STANDARD PREVIEW

*Aéronautique et espace — Tuyauteries flexibles en polytétrafluoréthylène (PTFE),  
série normale, classification 204 °C/21 000 kPa — Spécification  
d'approvisionnement*

[ISO 9528:1989](#)

<https://standards.iteh.ai/catalog/standards/sist/e9473fe2-d84c-4b08-bc33-cb4c00783eb1/iso-9528-1989>



Reference number  
ISO 9528 : 1989 (E)

## Foreword

ISO (the International Organization for Standardization) is a worldwide federation of national standards bodies (ISO member bodies). The work of preparing International Standards is normally carried out through ISO technical committees. Each member body interested in a subject for which a technical committee has been established has the right to be represented on that committee. International organizations, governmental and non-governmental, in liaison with ISO, also take part in the work. ISO collaborates closely with the International Electrotechnical Commission (IEC) on all matters of electrotechnical standardization.

Draft International Standards adopted by the technical committees are circulated to the member bodies for approval before their acceptance as International Standards by the ISO Council. They are approved in accordance with ISO procedures requiring at least 75 % approval by the member bodies voting.

International Standard ISO 9528 was prepared by Technical Committee ISO/TC 20, *Aircraft and space vehicles*.

Annex A of this International Standard is for information only. [9528:1989](#)

<https://standards.iteh.ai/catalog/standards/sist/e9473fe2-d84c-4b08-bc33-cb4e00783eb1/iso-9528-1989>

© ISO 1989

All rights reserved. No part of this publication may be reproduced or utilized in any form or by any means, electronic or mechanical, including photocopying and microfilm, without permission in writing from the publisher.

International Organization for Standardization  
Case postale 56 • CH-1211 Genève 20 • Switzerland

Printed in Switzerland

# Aerospace — Standard-weight polytetrafluoroethylene (PTFE) hose assemblies, classification 204 °C/21 000 kPa — Procurement specification

## 1 Scope

This International Standard specifies requirements for standard-weight polytetrafluoroethylene (PTFE) hose assemblies for use in aircraft hydraulic systems at temperatures between  $-55\text{ °C}$  and  $+204\text{ °C}$  and at a nominal pressure up to 21 000 kPa (210 bar). The hose assemblies are also suitable for use within the same temperature and pressure limitations in aircraft pneumatic systems where some gaseous diffusion through the wall of the PTFE liner can be tolerated.

The use of these hose assemblies in high-pressure pneumatic storage systems is not recommended. In addition, installations in which the limits specified in this International Standard are exceeded, or in which the application is not covered specifically by this International Standard, for example for oxygen, shall be subject to the approval of the purchaser.

## 2 Normative references

The following standards contain provisions which, through reference in this text, constitute provisions of this International Standard. At the time of publication, the editions indicated were valid. All standards are subject to revision, and parties to agreements based on this International Standard are encouraged to investigate the possibility of applying the most recent editions of the standards indicated below. Members of IEC and ISO maintain registers of currently valid International Standards.

ISO/TR 2685 : 1984, *Aircraft — Environmental conditions and test procedures for airborne equipment — Resistance to fire in designated fire zones.*

ISO 2859-1 : 1989, *Sampling procedures for inspection by attributes — Part 1: Sampling plans indexed by acceptable quality level (AQL) for lot-by-lot inspection.*

ISO 5855-3 : 1988, *Aerospace construction — MJ threads — Limit dimensions for fitting for fluid systems.*

ISO 6772 : 1988, *Aerospace fluid systems — Impulse testing of hydraulic hose, tubing and fitting assemblies.*

ISO 7258 : 1984, *Polytetrafluoroethylene (PTFE) tubing for aerospace applications — Methods for the determination of the density and relative density.*

ISO 8829 : 1990, *Aerospace — Polytetrafluoroethylene (PTFE) hose assemblies — Test methods.*

## 3 Requirements

### 3.1 Qualification

Hose assemblies supplied in accordance with this International Standard shall be representative of products which have been subjected to and which have successfully passed the requirements and tests specified in this International Standard.

### 3.2 Materials

#### 3.2.1 General

The hose assembly materials shall be as described in this International Standard (see, in particular, annex A). All materials not specifically described in this International Standard shall be of the highest quality and suitable for the purpose intended.

#### 3.2.2 Metals

Metals used in the hose and fittings shall be corrosion-resistant or titanium and shall conform to the applicable specifications described in table 1 (or equivalent specifications; see annex A).

Table 1 — Metals to be used in hose assemblies

Form	Metal	Material No. (see annex A)
Bars and forgings	Austenitic, annealed or as-rolled, corrosion-resistant steel	1
	Austenitic, annealed or as-rolled, stabilized, corrosion-resistant steel	2 and 3
	Precipitation-hardening, corrosion-resistant steel	4, 5 and 6
	Titanium 6Al-4V	7
Tubing	Austenitic, seamless or welded, annealed, corrosion-resistant steel	8
	Austenitic, seamless or welded, stabilized, corrosion-resistant steel	9 and 10
	Cold-worked, stress-relieved titanium alloy	11
Wire	Austenitic, cold-drawn, corrosion-resistant steel	12, 13 and 14

### 3.3 Construction

#### 3.3.1 General

The hose assembly shall consist of

- a seamless PTFE inner tube (see 3.3.2);
- corrosion-resistant steel-wire reinforcement (see 3.3.3), and
- corrosion-resistant steel and/or titanium end-fittings (see 3.3.4),

as required to meet the construction and performance requirements laid down in this International Standard and as required for its intended use.

#### 3.3.2 Inner tube

The inner tube shall be of a seamless construction of virgin PTFE resin of uniform gauge; it shall have a smooth bore and shall be free from pitting or projections on the inner surface. Additives may be included in the compound from which the tube is extruded.

#### 3.3.3 Reinforcement

The reinforcement shall consist of corrosion-resistant steel wire conforming to the applicable specifications given in 3.2.2. The wires shall be arranged over the inner tube so as to provide sufficient strength to ensure compliance with the requirements laid down in this International Standard.

Broken or missing reinforcing wires shall be cause for rejection; crossed-over reinforcing wires shall not be cause for rejection of the hose assembly.

#### 3.3.4 Fittings

##### 3.3.4.1 General

It shall be proven that all fittings comply with the requirements laid down in this International Standard. Unless otherwise specified by the purchaser, the hose assemblies shall have flareless fittings (24° cone coupling).

NOTE — An International Standard (ISO/DP 7321) specifying the geometric definition of a 24° cone coupling is currently being prepared.

##### 3.3.4.2 Insert fittings

Insert fittings shall be manufactured in one piece wherever possible; those made of other than one-piece construction shall be butt-welded, unless otherwise agreed by the purchaser, from annealed, austenitic, corrosion-resistant steel tubing. Welded and redrawn tubing (materials Nos. 8 and 9; see annex A) may be used.

### 3.4 Inner tube

#### 3.4.1 Density and relative density

The relative density of the hose inner tube shall not exceed 2,155, when tested in accordance with ISO 7258, either method A or method B (as specified in ISO 8829). The density shall not exceed 2,204 g/cm<sup>3</sup>, when tested in accordance with ISO 7258, method C (as specified in ISO 8829).

#### 3.4.2 Tensile strength

When tested in accordance with ISO 8829 : 1990, 4.2, the longitudinal tensile strength for all sizes of tubes shall be at least 15,1 N/mm<sup>2</sup>\*).

When tested in accordance with ISO 8829 : 1990, 4.2, the transverse tensile strength for sizes DN16 and larger shall be at least 12,4 N/mm<sup>2</sup>; for sizes under DN16, the transverse strength need not be tested.

#### 3.4.3 Elongation

When tested in accordance with ISO 8829 : 1990, 4.2, the elongation shall be at least 200 %.

#### 3.4.4 Tube roll

The tube shall not leak, split, burst or show any signs of malfunction, when tested through the sequence as specified in ISO 8829 : 1990, 4.3.2.

#### 3.4.5 Tube proof-pressure

After being subjected to the tube roll test sequence (see 3.4.4), the tube, without reinforcing wires, shall not leak, burst or show any signs of malfunction, when tested as specified in ISO 8829 : 1990, 4.3.3.

#### 3.4.6 Electrical conductivity

When tested in accordance with ISO 8829 : 1990, 4.4, the electrical current shall be equal to or greater than

- a) 10 µA for sizes DN06 to DN12 (incl.);
- b) 20 µA for sizes DN16 and over.

### 3.5 Hose

#### 3.5.1 Dimensional requirements

The hose assembly dimensions, except for length, shall be as specified in figure 1 and table 2.

#### 3.5.2 Physical requirements

Hose assemblies shall comply with the physical and linear density (weight) requirements specified in table 3.

\*) 1 N/mm<sup>2</sup> = 1 MPa

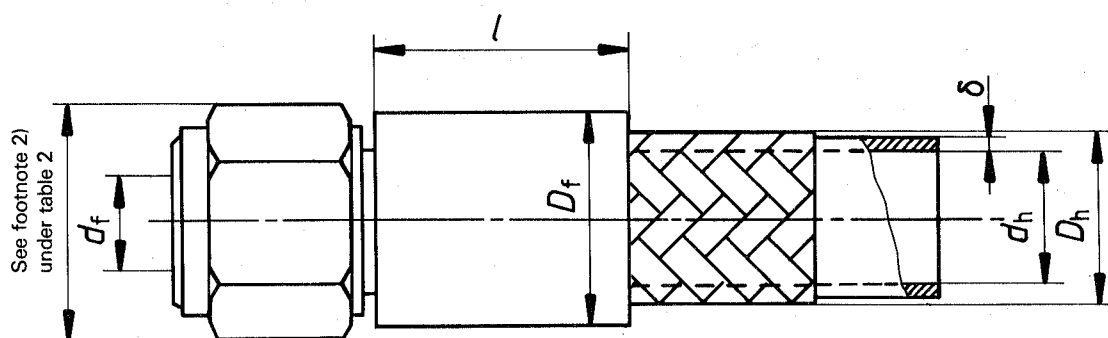

Figure 1 – Hose and fitting dimensions

Table 2 – Hose and fitting dimensions (see figure 1)

Dimensions in millimetres

Hose size (nom.)	Hose (braided)			Fitting		Attachment length $l$ max.	Wall thickness of inner tube $\delta$ min.
	Inside diameter $d_h$ min.	Outside diameter $D_h$ min. max.		Inside diameter <sup>1)</sup> $d_f$ min.	Outside diameter <sup>2)</sup> $D_f$ max.		
DN06	5,3	10,2	11,8	3,3	23	58	0,89
DN10	7,5	13,6	15,1	6,1	26	64	
DN12	9,9	17,1	18,6	8,6	31	70	1
DN16	12,3	22,2	23,7	10,4	36	76	
DN20	15,3	26,1	27,7	12,9	43	83	1,1
DN25	21,6	34,2	35,8	19,3	51	96	
DN32	28	39,6	41,9	23,5	54	99	1,27

1) Minimum inside diameter through the elbow area may be 0,8 mm less than the values given for  $d_f$ .

2) Width across corners of nut and socket hexagon may exceed the values given for  $D_f$ .

Table 3 – Physical requirements of hose assemblies and linear density (weight) of hose

Hose size	Linear density (weight) of hose <sup>1)</sup> max. kg/m	Operating pressure kPa	Proof pressure kPa	Burst pressure		Bend radius at inside of bend min. mm	Volumetric expansion max. ml/m
				at room temperature min. kPa	at high temperature min. kPa		
DN06	0,295	21 000	42 000	84 000	63 000	76	2,6
DN10	0,5					127	3,4
DN12	0,72					146	5,3
DN16	1,11					165	8,7
DN20	1,54					197	11,8
DN25	2,51					245	29,5
DN32	3,22					305	39,4

1) The linear density (weight) of the hose shall be determined on a minimum length of 300 mm.

### 3.5.3 Bore check

When bent to the appropriate minimum bend radius as specified in table 3, the hose assembly shall permit the free passage of a solid rigid sphere throughout its length. The diameter of the sphere shall be 90 % of the appropriate minimum internal diameter of the end fittings as specified in table 2; for elbow fittings, see footnote 1) to table 2.

### 3.6 Screw threads

Unless otherwise specified (see 3.3.4), fitting threads shall be in accordance with ISO 5855-3. A 10 % increase in the tolerance of the fitting thread of the nut during assembly or testing shall not be cause for rejection of the hose assembly.

### 3.7 Part numbering of interchangeable parts

All parts complying with this International Standard and having the same manufacturer's or standard part number shall be functionally and dimensionally interchangeable.

### 3.8 Identification of products

#### 3.8.1 General

The hose assembly and its component parts shall be permanently marked.

#### 3.8.2 Fittings

The manufacturer's name or trade-mark shall be permanently marked on one element of all end fittings.

#### 3.8.3 Hose assembly

A permanent marking shall be applied on a fitting or on a permanent band or bands securely attached to the hose. Bands shall be no wider than 25 mm and shall not impair the flexibility or the performance of the hose. Unless otherwise specified, the marking on the fitting or band shall include the following information:

- a) the assembly manufacturer's name or trade-mark, and specification number;
- b) the complete hose assembly part number;
- c) the nominal pressure "21 000 kPa", as applicable;
- d) the operating temperature, "204 °C", if required;
- e) the pressure test symbol, "PT";
- f) the date of hose assembly manufacture, expressed in terms of month and year, or batch number.

### 3.9 Workmanship

#### 3.9.1 General

The hose assembly, including all parts, shall be constructed and finished in a thoroughly workmanlike manner. All surfaces shall be free from burrs.

### 3.9.2 Dimensions and tolerances

All pertinent dimensions and tolerances, where interchangeability, operation or performance of the hose assembly may be affected, shall be specified on all drawings.

### 3.9.3 Cleaning

All hose assemblies shall be free from oil, grease, dirt or other foreign materials, both internally and externally.

### 3.10 Hose assembly — Test and performance requirements

#### 3.10.1 Proof pressure

When tested in accordance with ISO 8829 : 1990, 5.8, each hose assembly shall withstand the proof pressure specified in table 3 without malfunction or leakage.

#### 3.10.2 Elongation and contraction

When two test specimens of the sample hose assemblies are tested in accordance with ISO 8829 : 1990, 5.5, there shall be no change in length by more than 2 % in a 250 mm gauge length.

#### 3.10.3 Volumetric expansion

When two test specimens of the sample hose assemblies are tested in accordance with ISO 8829 : 1990, 5.6, the volumetric expansion shall not exceed the limits specified in table 3.

#### 3.10.4 Leakage

When two test specimens of the sample hose assemblies are tested in accordance with ISO 8829 : 1990, 5.7, there shall be no leakage.

#### 3.10.5 Thermal shock

**3.10.5.1** Two test specimens of the sample hose assemblies shall be tested: one test specimen shall be air-aged and the other shall be unaged (see 4.5.6).

**3.10.5.2** When tested in accordance with ISO 8829 : 1990, 5.17, the test specimens shall neither leak nor show any signs of malfunction during the proof pressure phase of the test; during the burst pressure phase of the test, if leakage or signs of malfunction occur below the minimum burst pressure at high temperature specified in table 3, the samples shall be deemed to have failed.

#### 3.10.6 Impulse

##### 3.10.6.1 Preconditioning

Six sample hose assemblies having a 90° elbow fitting on one end and a straight fitting on the other end shall be tested: two test specimens shall be oil-aged, two air-aged, and two unaged (see 4.5.6).

After this initial preconditioning, subject the test specimens at room temperature to the proof pressure specified in table 3 for at least 5 min. Then pressurize the test specimens to 21 000 kPa. While maintaining this pressure at room temperature, immerse the test specimens in a 3,5 % (V/V) ± 0,1 % (V/V) sodium chloride solution — the sodium chloride solution shall contain a dry basis of not more than 0,1 % (m/m) sodium iodine and 0,5 % (m/m) total impurities — for 8 min to 10 min. Allow to dry in air for the remainder of 1 h. Repeat this subsequent immersion and air-drying process no fewer than 50 times.

**3.10.6.2 Requirement**

When tested in accordance with ISO 8829 : 1990, 5.10 (i.e. in accordance with ISO 6772), the sample hose assemblies shall comply with the test requirements without any signs of leakage [see also item h) in clause 6].

**3.10.7 Assembly flexibility**

When two test specimens of the sample hose assemblies are flexure-tested in accordance with ISO 8829 : 1990, 5.11, they shall not leak or show any other signs of malfunction. The test specimens shall be mounted in a test set-up, shown in figure 2, having the dimensions specified in the table accompanying figure 2.

**3.10.8 Stress degradation**

When two test specimens of the sample hose assemblies are tested in accordance with ISO 8829 : 1990, 5.1, they shall not exceed an average rate of effusion of 80 ml/min per metre of hose length for any size.

iTeh STANDARD PREVIEW  
(standards.iteh.ai)  
https://standards.iteh.ai/catalog/standards/sist/e9473fe2-d84c-4b08-bc33-cb4e00783eb1/iso-9528-1989

**3.10.9 Pneumatic surge**

When two test specimens of the sample hose assemblies are tested in accordance with ISO 8829 : 1990, 5.16, the inner tubes of the test specimens shall not collapse or show signs of degradation.

**3.10.10 Pneumatic effusion**

When two test specimens of the sample hose assemblies are tested in accordance with ISO 8829 : 1990, 5.2, they shall not exceed a total rate of effusion of 26 ml per metre of hose length for any size.

**3.10.11 Repeated installation**

**3.10.11.1 Requirement**

When two test specimens of the sample hose assemblies are tested in accordance with the procedure outlined 3.10.11.2, the assembly end fittings shall show no signs of leakage, galling or other malfunction.

**3.10.11.2 Procedure**

Screw end fittings on hose assemblies to appropriate union adaptors eight times using system fluid or an equivalent lubricant. Each of the eight cycles shall include the complete

removal of the hose fitting from the manifold union. Tighten fitting nuts to the torques specified; test one half of the sample to the minimum tightening torque and test the other half to the maximum tightening torque. Following the first, fourth, and eighth installation, carry out proof pressure tests. Following the eighth installation, pressure-test the hose fittings with air or nitrogen gas for 5 min at the nominal system pressure.

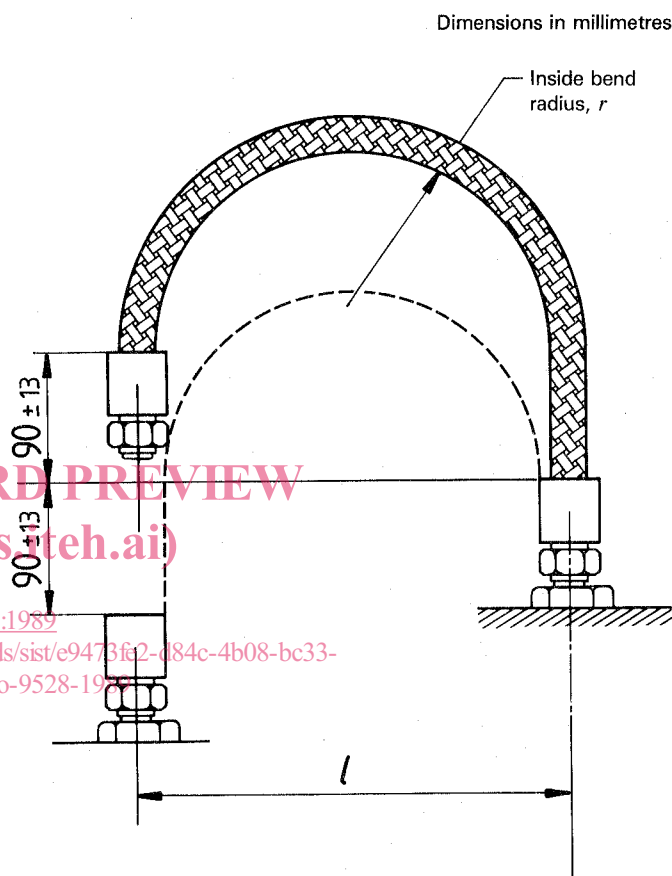

Hose size	r ± 10 %	l (approx.)
DN06	76	163
DN10	127	270
DN12	146	310
DN16	165	355
DN20	197	420
DN25	245	530
DN32	305	651

Figure 2 — Test set-up for flexure test

**3.10.12 Burst pressure at room temperature**

When two test specimens of the sample hose assemblies are tested in accordance with ISO 8829 : 1990, 5.9, they shall not leak or burst at any pressure below the burst pressure at room temperature specified in table 3.



### 3.10.13 Electrical conductivity

When one test specimen of the sample hose assemblies is tested in accordance with ISO 8829 : 1990, 5.3, the electrical current conducted shall be equal to or greater than

- a) 6  $\mu$ A for sizes DN06 to DN12 (incl.);
- b) 12  $\mu$ A for sizes DN16 and over.

### 3.10.14 Fire resistance

**3.10.14.1** If the hose assemblies are required to withstand a specified resistance to fire, two test specimens of the sample hose assemblies, which may be fitted with fire sleeves (component No. 1; see annex A) or equivalent, shall be tested in accordance with ISO/TR 2685 (as specified in ISO 8829).

NOTE — On occasions, a test may not be valid because of failure to hold the flame temperature at the specified value; for this reason it is advised to prepare four hose assemblies for this test.

**3.10.14.2** The test specimens shall withstand the effects of the flame without leakage for the following periods as appropriate:

- fire-resistant assemblies: 5 min;
- fireproof assemblies: 15 min.

## 4 Quality assurance

### 4.1 Responsibility for inspection

Unless otherwise specified in the contract or purchase order, the supplier is responsible for carrying out all inspections and tests in accordance with the requirements specified in this International Standard. Unless otherwise specified, the supplier may use his own facilities or any commercial laboratory acceptable to the procuring activity. The purchaser reserves the right to perform any of the inspections set out in the procurement specification (i.e. this International Standard) where such inspections are deemed necessary to ensure that supplies and services conform to specified requirements.

### 4.2 Classification of inspections

The examining and testing of hose assemblies shall be classified as:

- a) qualification inspections (see 4.3);
- b) quality conformance inspections (see 4.4).

### 4.3 Qualification inspections

#### 4.3.1 Qualification test samples

Test samples shall consist of the number of test specimens specified in table 4 and the number and lengths of test specimens specified in table 5.

#### 4.3.2 Test report, test samples, and data for the purchaser

If the tests are carried out at a location other than the laboratory of the purchaser, the following information shall be made available to the purchaser on request:

- a) test report: three copies of a test report which shall include a report of all tests and outline description of the tests and conditions;
- b) test sample: the sample which was tested, when requested by the purchaser;
- c) list of sources of hose or hose components, including source's name and product identification for inner tube, hose and assembly.

Log sheets, containing required test data, shall remain on file at the source test facility and are not to be sent to the qualifying activity unless specifically requested.

#### 4.3.3 Qualification testing

Qualification testing shall consist of all the examinations and tests specified in 3.4 and 3.10; the test sequence shall be as shown in table 4.

### 4.4 Quality conformance inspections

#### 4.4.1 General

Quality conformance inspections shall be sampled in accordance with the procedure laid down in ISO 2859 and shall consist of the following tests:

- a) individual tests — 100 % inspection (see 4.4.2);
- b) sampling tests (see 4.4.3);
- c) periodic control tests (see 4.4.4).

#### 4.4.2 Individual tests

Each hose assembly shall be subjected to the following tests:

- a) general examination of product (see 3.5 to 3.9);
- b) proof pressure tests (see 3.10.1).

Production samples that are proof-pressure-tested with water shall be air-dried prior to capping (see cleaning requirements in 3.9.3).

#### 4.4.3 Sampling tests

The following inspections or tests shall be carried out in the order indicated:

- a) density and relative density (see 3.4.1);
- b) internal cleanliness (see 3.9.3);
- c) leakage tests (see 3.10.4);
- d) burst pressure at room temperature (see 3.10.12).



Table 4 – Qualification test sequence and number of test specimens in sample

Relevant inspection/test		Inner tube	Sample hose assemblies																
			Test specimen No.																
			1	2	3	4	5	6	7	8	9	10	11	12	13	14	15	16	17
3.3	General examination <sup>1)</sup>	X X																	
3.4.1	Density and relative density <sup>1)</sup>	X X																	
3.4.2	Tensile strength <sup>1)</sup>	X X																	
3.4.3	Elongation <sup>1)</sup>	X X																	
3.4.4	Tube roll <sup>1)</sup>	X X																	
3.4.5	Proof pressure <sup>1)</sup>	X X																	
3.4.6	Electrical conductivity <sup>1)</sup>	X X																	
3.5 to 3.9	General examination		X	X	X	X	X	X	X	X	X	X	X	X	X	X	X	X	
3.10.1	Proof pressure		X	X	X	X	X	X	X	X	X	X	X	X	X	X	X	X	
3.10.2	Elongation and contraction		X	X															
3.10.3	Volumetric expansion				X	X													
3.10.4	Leakage						X	X											
3.10.5	Thermal shock and burst pressure at high temperature						X	X											
3.10.6	Impulse	Unaged <sup>2)</sup>							X	X									
		Air-aged								X	X								
		Oil-aged										X	X						
3.10.7	Flexure		X	X															
3.10.8	Stress degradation													X	X				
3.10.9	Pneumatic surge												X	X					
3.10.10	Pneumatic effusion				X	X													
3.10.11	Repeated installation		X	X															
3.10.12	Burst pressure at room temperature				X	X													
3.10.13	Electrical conductivity																X		
3.10.14	Fire resistance (when required)																	X	X

Key: X means one inspection/test.

1) Production lot records may be used to verify conformance to these tests if the PTFE tube or hose assembly being used is an established production item.

2) These test specimens shall have a 90° elbow fitting on one end of the hose and a straight-type fitting on the other end of the hose. If approval is being sought for both the bent-tube and the forged-elbow configuration, then one-half of the sample (i.e. three test specimens) shall use the bent elbows, while the other half of the sample shall have the forged elbows.

Table 5 – Length of test specimens

Lengths in millimetres

Hose size	Length of test specimens				
	for flexure tests (3.10.7) (Two specimens, Nos. 1 and 2)	for impulse tests (3.10.6) (Six specimens, Nos. 7 to 12)	for electrical conductivity test (3.10.13) (One specimen, No. 15)	for fire resistance (3.10.14) (Two specimens, Nos. 16 and 17)	for other tests (Six specimens, Nos. 3 to 6 and Nos. 13 and 14)
DN06	510	405	One sample for each size with a specimen length as specified in ISO 8829	600	500
DN10	685	535			
DN12	765	610			
DN16	840	765			
DN20	940	840			
DN25	1 145	1 040			
DN32	1 425	1 320			