



SLOVENSKI STANDARD SIST EN 3645-001:2009

01-maj-2009

5 YfcbUj h_U'!'?cbY_lcf^ZY_Y_hf] b]žc_fc[`]žnUý]hYb`_cbhU_hž\]fUgdc^_Un
bUj c^Ya žghU_bUXYcj bUHya dYfUhi fU%+) `š7 `U]`&\$\$`š7 `!`\$\$%`XY.`HY\ b] bU
gdYWZ_UWU

Aerospace series - Connectors, electrical, circular, scoop-proof, triple start threaded coupling, operating temperature 175 °C or 200 °C continuous - Part 001: Technical specification

STANDARD PREVIEW

Luft- und Raumfahrt - Elektrische Rundsteckverbinder, kontaktgeschützt, dreigängige Gewinde-Schnellkupplung, Betriebstemperatur 175 °C oder 200 °C konstant - Teil 001: Technische Lieferbedingungen

[SIST EN 3645-001:2009](https://standards.iteh.ai/catalog/standards/sist/1c9b2ccc-8387-474c-925b-11eb-9122-41711b00503c)

[https://standards.iteh.ai/catalog/standards/sist/1c9b2ccc-8387-474c-925b-](https://standards.iteh.ai/catalog/standards/sist/1c9b2ccc-8387-474c-925b-11eb-9122-41711b00503c)

Série aérospatiale - Connecteurs électriques circulaires à accouplement par filetage, à pas rapide à trois filets, température d'utilisation 175 °C ou 200 °C continu - Partie 001 : Spécification technique

Ta slovenski standard je istoveten z: EN 3645-001:2007

ICS:

49.060 Š^cp \ æš Á^•[|b \ æ Aerospace electric
^|\ dã} æ\]!^ { æš Á ã c^ { ã equipment and systems

SIST EN 3645-001:2009

en,de

iTeh STANDARD PREVIEW
(standards.iteh.ai)

SIST EN 3645-001:2009

<https://standards.iteh.ai/catalog/standards/sist/1c9b2ccc-8387-474c-925b-6de3d3712a48/sist-en-3645-001-2009>

EUROPEAN STANDARD

EN 3645-001

NORME EUROPÉENNE

EUROPÄISCHE NORM

March 2007

ICS 49.060

English Version

**Aerospace series - Connectors, electrical, circular, scoop-proof,
triple start threaded coupling, operating temperature 175 °C or
200 °C continuous - Part 001: Technical specification**

Série aéronautique - Connecteurs électriques circulaires à
accouplement par filetage, à pas rapide à trois filets,
température d'utilisation 175 °C ou 200 °C continu - Partie
001 : Spécification technique

Luft- und Raumfahrt - Elektrische
Rundsteckverbinder, kontaktgeschützt, Drei-gängige
Gewinde-Schnellkupplung, Betriebstemperatur 175 °C oder
200 °C konstant - Teil 001: Technische Lieferbedingungen

This European Standard was approved by CEN on 30 September 2005.

CEN members are bound to comply with the CEN/CENELEC Internal Regulations which stipulate the conditions for giving this European Standard the status of a national standard without any alteration. Up-to-date lists and bibliographical references concerning such national standards may be obtained on application to the CEN Management Centre or to any CEN member.

This European Standard exists in three official versions (English, French, German). A version in any other language made by translation under the responsibility of a CEN member into its own language and notified to the CEN Management Centre has the same status as the official versions.

CEN members are the national standards bodies of Austria, Belgium, Bulgaria, Cyprus, Czech Republic, Denmark, Estonia, Finland, France, Germany, Greece, Hungary, Iceland, Ireland, Italy, Latvia, Lithuania, Luxembourg, Malta, Netherlands, Norway, Poland, Portugal, Romania, Slovakia, Slovenia, Spain, Sweden, Switzerland and United Kingdom.



EUROPEAN COMMITTEE FOR STANDARDIZATION
COMITÉ EUROPÉEN DE NORMALISATION
EUROPÄISCHES KOMITEE FÜR NORMUNG

Management Centre: rue de Stassart, 36 B-1050 Brussels

Contents		Page
Foreword.....		3
0 Introduction		4
1 Scope		4
2 Normative references		4
3 Definitions		5
4 Description		5
5 Design		7
6 Dimensions and masses		8
7 Tests.....		38
8 Quality assurance		52
9 Designation and marking.....		59
10 Delivery conditions.....		60
11 Packaging		60
12 Storage.....		60

iTeh STANDARD PREVIEW
(standards.iteh.ai)

[SIST EN 3645-001:2009](https://standards.iteh.ai/catalog/standards/sist/1c9b2ccc-8387-474c-925b-6de3d3712a48/sist-en-3645-001-2009)

<https://standards.iteh.ai/catalog/standards/sist/1c9b2ccc-8387-474c-925b-6de3d3712a48/sist-en-3645-001-2009>

Foreword

This document (EN 3645-001:2007) has been prepared by the Aerospace and Defence Industries Association of Europe - Standardization (ASD-STAN).

After enquiries and votes carried out in accordance with the rules of this Association, this Standard has received the approval of the National Associations and the Official Services of the member countries of ASD, prior to its presentation to CEN.

This European Standard shall be given the status of a national standard, either by publication of an identical text or by endorsement, at the latest by September 2007, and conflicting national standards shall be withdrawn at the latest by September 2007.

According to the CEN/CENELEC Internal Regulations, the national standards organizations of the following countries are bound to implement this European Standard: Austria, Belgium, Bulgaria, Cyprus, Czech Republic, Denmark, Estonia, Finland, France, Germany, Greece, Hungary, Iceland, Ireland, Italy, Latvia, Lithuania, Luxembourg, Malta, Netherlands, Norway, Poland, Portugal, Romania, Slovakia, Slovenia, Spain, Sweden, Switzerland and the United Kingdom.

iTeh STANDARD PREVIEW (standards.iteh.ai)

[SIST EN 3645-001:2009](https://standards.iteh.ai/catalog/standards/sist/1c9b2ccc-8387-474c-925b-6de3d3712a48/sist-en-3645-001-2009)

<https://standards.iteh.ai/catalog/standards/sist/1c9b2ccc-8387-474c-925b-6de3d3712a48/sist-en-3645-001-2009>

EN 3645-001:2007 (E)**0 Introduction**

This family of connectors is derived from MIL-DTL-38999 series III, with which it is intermateable and interchangeable. It is particularly suitable for use in zones of severe environmental conditions on board aircraft, applying EN 2282.

1 Scope

This standard specifies the general characteristics, the conditions for qualification, acceptance and quality assurance, as well as the test programs and groups for threaded ring coupling circular connectors, fire-resistant, intended for use in a temperature range from – 65 °C to 175 °C continuous or 200 °C continuous according to the classes and models.

2 Normative references

The following referenced documents are indispensable for the application of this document. For dated references, only the edition cited applies. For undated references, the latest edition of the referenced document (including any amendments) applies.

ISO 68-1, *ISO general purpose screw threads — Basic profile — Part 1: Metric screw threads*

ISO 261, *ISO general-purpose metric screw threads — General plan*

ISO 262, *ISO general-purpose metric screw threads — Selected sizes for screws, bolts and nuts*

ISO 965-2, *ISO general purpose metric screw threads — Tolerances — Part 2: Limit sizes for general purpose external and internal screw threads — Medium quality*

ISO 4524-1, *Metallic coatings — Test methods for electrodeposited gold and gold alloy coatings — Part 1: Determination of coating thickness*

EN 2267-002, *Aerospace series — Cables, electrical, for general purpose — Operating temperatures between – 55 °C and 200 °C — Part 002: General*

EN 2282, *Aerospace series — Characteristics of aircraft electrical supplies*

EN 2346-002, *Aerospace series — Cables, electrical, fire resistant — Operating temperature between – 65 °C to 260 °C — Part 002: General*

EN 2591 (series), *Aerospace series — Elements of electrical and optical connection — Test methods*

EN 2591-100, *Aerospace series — Elements of electrical and optical connection — Test methods — Part 100: General*

EN 2591-101, *Aerospace series — Elements of electrical and optical connection — Test methods — Part 101: Visual examination*

EN 2591-213, *Aerospace series — Elements of electrical and optical connection — Test methods — Part 213: Shielding effectiveness from 100 MHz to 1 GHz*

EN 2591-306, *Aerospace series — Elements of electrical and optical connection — Test methods — Part 306: Mould growth*

EN 9133, *Aerospace series — Quality management systems — Qualification Procedure for Aerospace Standard Parts*

EN 3197, *Aerospace series — Installation of aircraft electrical and optical interconnection systems*¹⁾

1) In preparation at the date of publication of this standard.

EN 3645-002, *Aerospace series — Connectors, electrical, circular, scoop-proof, triple start threaded coupling, operating temperature 175 °C or 200 °C continuous — Part 002: Specification of performance and contact arrangements*

AS 1241C, *Fire resistant phosphate ester hydraulic fluid for aircraft* ²⁾

MIL-A-8243D, *Anti-icing and deicing-defrosting fluids* ³⁾

MIL-C-25769J, *Cleaning compound, aircraft surface, alkaline water base fluids* ³⁾

MIL-DTL-38999K, *Connectors, electrical, circular, miniature, high density, quick disconnect (bayonet, threaded, and breech coupling), environment resistant, removable crimp and hermetic solder contacts, general specification for* ³⁾

MIL-HDBK-454, *General guidelines for electronic equipment* ³⁾

MIL-H-5606G, *Hydraulic fluid, petroleum base; aircraft; missile and ordnance* ³⁾

MIL-PRF-7808L, *Lubricating oil, aircraft turbine engine, synthetic base* ³⁾

MIL-PRF-23699F, *Lubricating oil, aircraft turbine engine, synthetic base, NATO Code Number O-156* ³⁾

MIL-PRF-7870C, *Lubricating oil, general purpose, low temperature* ³⁾

MIL-STD-1373, *Screw-thread, modified, 60°, stub, double* ³⁾

TR 4257, *Aerospace series — Elements of electrical and optical connection — Relationship between the numbering systems for parts of EN 2591* ⁴⁾

3 Definitions

See EN 2591-100.

iTeh STANDARD PREVIEW
(standards.iteh.ai)

4 Description

4.1 General

[SIST EN 3645-001:2009](https://standards.iteh.ai/catalog/standards/sist/1c9b2ccc-8387-474c-925b-c517151d8602/en-3645-001-2009)

[https://standards.iteh.ai/catalog/standards/sist/1c9b2ccc-8387-474c-925b-](https://standards.iteh.ai/catalog/standards/sist/1c9b2ccc-8387-474c-925b-c517151d8602/en-3645-001-2009)

Different variants of materials, housings and contact arrangements are provided according to the models depending on the service conditions.

The pair of connectors is characterized:

- by the mechanical stop of the shells on the coupling;
- by its triple threaded and self-locking coupling system;
- by plugs with shielding ring providing protection against radioelectrical interference;
- by the scoop-proof shells.

These connectors use the following contacts:

- crimped sizes 22, 20, 16, 12 and 10,
 - soldered (model Y) sizes 22, 20, 16 and 12,
 - coaxial crimped or soldered sizes 16, 12 and 8,
 - triaxial crimped or soldered size 8.
- } For arrangements comprising the letter G, all contacts are grounded to the receptacle housing

The receptacles and plugs contain either male contacts or female contacts.

The contacts fitted in the model Y receptacles are exclusively of the male solder type.

2) Published by: Society of Automotive Engineers, Inc. (SAE), 400 Commonwealth Drive, Warrendale, PA 15096-0001, USA.

3) Published by: Department of Defense (DOD), the Pentagon, Washington, DC 20301, USA.

4) Published as ASD Technical Report at the date of publication of this standard.

EN 3645-001:2007 (E)

The connectors are polarized by means of keyways and keys; polarization shall be obtained before the male contacts enter the insert of the female contacts and before the coupling ring is engaged. The position of the keying arrangement is given in Table 5.

The visual check of coupling is obtained by masking of a red colour band on the receptacle.

4.2 Receptacle

The receptacle housing may be attached:

- square flange;
- nut, with sealing by O-ring at the attachment;
- round soldered or brazed flange for model Y connectors.

4.3 Plug

The coupling ring is permanently fitted to the plug and allows coupling and uncoupling of the connectors. The lanyard release version may also be uncoupled by pulling on the lanyard.

The plug is fitted with a self-locking mechanism and a grounding spring device ensuring electrical continuity between the coupled connector housings.

4.4 Materials and surface treatment**4.4.1 General**

When dissimilar metals are in close contact, adequate protection against corrosion shall be used for the electromotive force of the cell not to exceed 0,25 V (see EN 3197).

4.4.2 Housings

The material of the housings for the connectors and fittings may be either aluminium alloy, passivated stainless steel or composite. Aluminium alloy and composite shall be plated as defined by the model (composite coupling rings may be unplated) (see EN 3645-002).

4.4.3 Contacts

Unless otherwise specified, the non-removable contacts shall be in ferrous alloy for models Y and in copper alloy for the other models.

They shall be gold-plated on an appropriate undercoat. Selective protection is authorized provided that it is sufficient to ensure that the specified performance is achieved.

Measurement of the thickness of the protective plating shall be effected in accordance with ISO 4524-1.

For removable contacts see EN 3645-002.

4.4.4 Non-metallic materials

The materials used for insert, seals and grommets shall have a hardness and mechanical and electrical characteristics consistent with the required use.

5 Design

5.1 Housings

The connector housings shall be one-piece. They shall contain teeth at the rear over their entire periphery and shall accommodate the rear accessories. The receptacle shall be fitted with a seal for sealing the coupled housings.

Jam nut receptacles shall contain an O-ring seal. The nut shall have holes for the passage of locking wire.

During coupling the grounding spring shall be engaged a minimum of 1,02 mm in the receptacle before the contacts engage.

Except for the triple start threads, which shall conform to standard MIL-STD-1373, threads shall conform to standards ISO 68-1, ISO 261, ISO 262 and ISO 965-2.

The coupling ring shall be designed so that the male and female contacts engage when it is turned in a clockwise direction and disengage when turned anticlockwise. The coupling threads may have a lubricant applied during manufacture.

Full locking of the connectors shall occur at about 360°. On completion of tightening of the coupling ring, mechanical contact shall exist between the receptacle and plug housings. Masking of a red colour band on the receptacle by the coupling nut shall show that the connectors are correctly coupled.

The receptacle has five keyways which engage with corresponding keys on the plug. The major key is fixed and is wider than the others. Polarization is ensured by the different positions which the minor keys may take. The position of the insert is fixed relative to the major key.

A blue-coloured band indicating that the crimped contacts of the connectors are rear-releasable shall be provided:

- in front of the flange on square flange receptacles;
- on the flange of jam nut receptacles;
- on the coupling ring of plugs.

This band shall be positioned so that at least one is visible when the connectors are fitted and when they are mated or unmated.

5.2 Inserts

The insert carrying the male and female contacts shall be in hard material and have a cross section and radii such that no cracks, flaking or breaks can occur in normal operation.

The insert for contacts shall be non-removable; it shall be mechanically held in the housing. Sealing shall be provided between the housing and insert.

The front face of the insert shall be such that sealing is ensured when the connectors are coupled. The interfacial seal of the insert of the male contacts shall be bonded on the hard insert.

The grommet shall permit sealing for all cable diameters indicated in EN 3645-002 and shall not be removable.

The mechanical contacts retention system shall be integrated in the hard insert.

The design of non-hermetic connectors shall permit individual installation of the contacts without removal of the insert or grommet. Fitting and removal of the contacts shall be from the rear with the tools specified in the contact product standards.

EN 3645-001:2007 (E)

Contact position identification shall be permanent and contrasted on the front face of the insert or the interfacial seal and on the rear face of the grommet as indicated in 6.5.

The marking shall not be recessed or raised on the surfaces providing a seal.

6 Dimensions and masses

The general dimensions and the masses of receptacles, plugs and protective covers are given in the product standards.

6.1 Receptacle mating dimensions

The mating dimensions of receptacles are shown in Figure 1 and details V and W as well as in Tables 1, 2 and 3.

iTeh STANDARD PREVIEW
(standards.iteh.ai)

[SIST EN 3645-001:2009](https://standards.iteh.ai/catalog/standards/sist/1c9b2ccc-8387-474c-925b-6de3d3712a48/sist-en-3645-001-2009)

<https://standards.iteh.ai/catalog/standards/sist/1c9b2ccc-8387-474c-925b-6de3d3712a48/sist-en-3645-001-2009>

Dimensions and tolerances are in millimetres

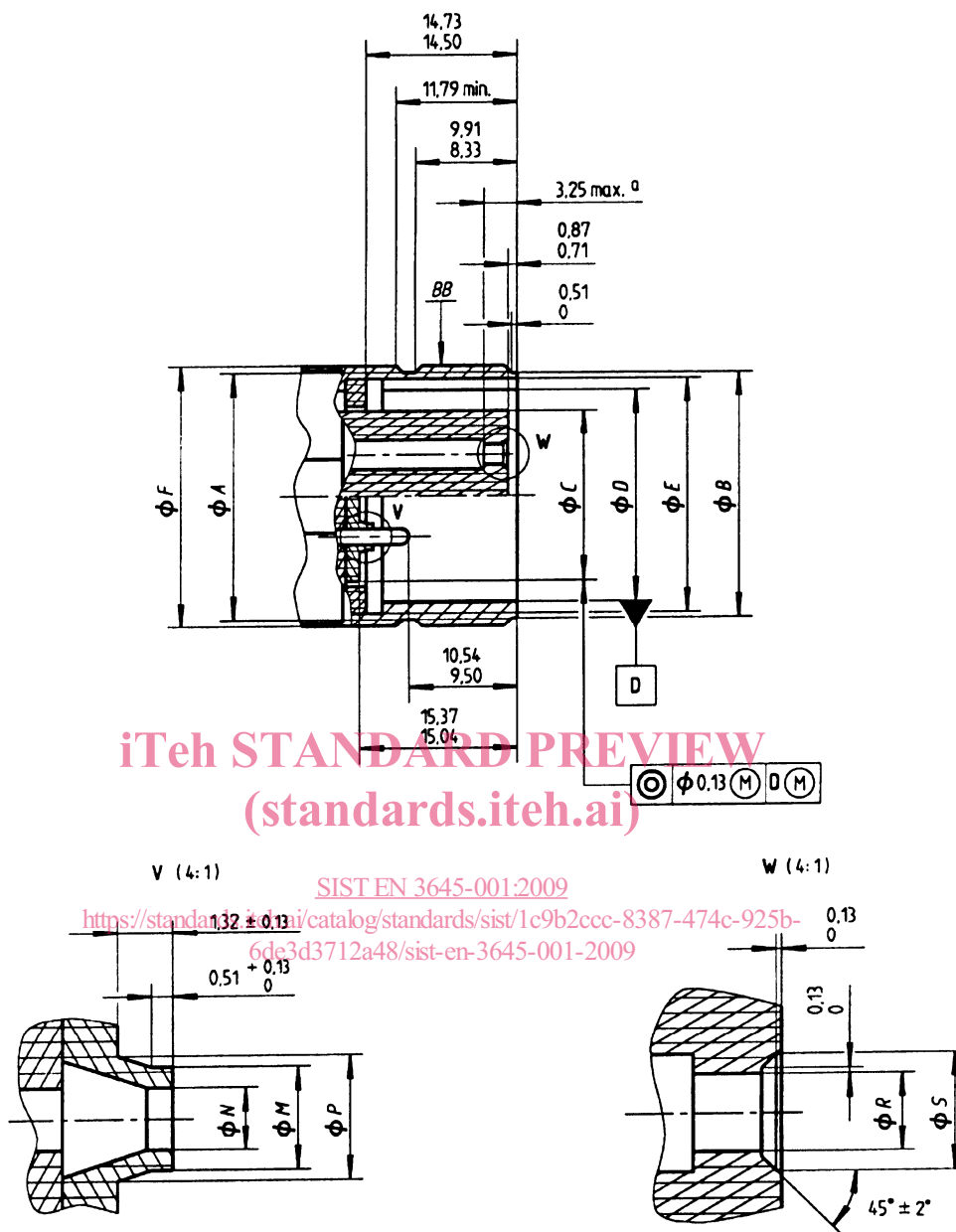

^a The distance between the front face of the shell and the point where the right end of a gauge with a diameter equal to the nominal diameter of a male contact comes into contact with the elastic part of the female contact.

Figure 1 — Receptacle — Coupling dimensions

EN 3645-001:2007 (E)

Table 1

Housing size	A	B	C	D	E	F
	max.		+ 0,13 - 0,25			max.
09	14,55	14,42 14,14	7,24	11,36 11,20	12,63 12,34	15,88
11	17,73	17,60 17,32	10,49	14,61 14,45	15,88 15,60	19,05
13	20,90	20,77 20,49	13,39	17,45 17,30	19,66 19,38	22,23
15	24,08	23,95 23,67	16,56	20,63 20,44	22,84 22,56	25,40
17	28,52	28,30 27,97	19,74	23,80 23,64	26,01 25,73	30,16
19	30,12	29,89 29,56	22,00	26,47 26,31	28,63 28,40	31,75
21	33,30	33,07 32,74	25,17	29,64 29,49	31,85 31,57	34,73
23	36,47	36,24 35,91	28,35	32,82 32,66	35,03 34,75	38,10
25	39,65	39,42 39,09	31,52	35,99 35,84	38,20 37,92	41,28

STANDARD PREVIEW
(standards.iteh.ai)

SIST EN 3645-001:2009

<https://standards.iteh.ai/catalog/standards/sist/1c9b2ccc-8387-474c-925b-6de3d3712a48/sist-en-3645-001-2009>

Table 2

Contact size	M	N	P	R	S
		max.			
22	1,35 1,27	0,71	1,88 1,75	0,97 0,89	1,70 1,60
20	1,91 1,83	0,97	2,44 2,31	1,32 1,24	2,26 2,16
16	2,49 2,41	1,52	3,02 2,90	1,88 1,80	2,84 2,74
12	3,30 3,23	2,34	3,84 3,71	2,69 2,62	3,66 3,56
10	4,09 4,01	3,12	4,62 4,50	3,48 3,40	4,45 4,34
8	6,50 6,38	5,49	7,06 6,93	5,84 5,77	6,81 6,71

Table 3

BB — Thread										
Housing size	Designation ^a Class 2A thread			See note ^b	External threading Class 2A					
	Thread size inch	Apparent pitch inch	Actual pitch inch		External diameter		Diameter on side		Diameter at thread end	
					max.	min.	max.	min.	max.	min.
09	0,6250	0,100	0,300	0,0381	15,83	15,63	15,17	14,97	14,41	14,05
11	0,7500				19,01	18,80	18,35	18,14	17,58	17,23
13	0,8750				22,18	21,98	21,52	21,32	20,76	20,41
15	1,0000				25,36	25,15	24,70	24,49	23,94	23,58
17	1,1875				30,11	29,80	29,24	28,99	28,28	27,82
19	1,2500			0,0508	31,69	31,39	30,83	30,58	29,87	29,41
21	1,3750				34,87	34,56	34,01	33,75	33,05	32,59
23	1,5000				38,04	37,74	37,18	36,93	36,22	35,76
25	1,6250				41,22	40,91	40,36	40,10	39,40	38,94

^a According to MIL-STD-1373.

^b Gauges for protected threads: it is permissible to increase the maximum limit for gauge diameters by the value specified in this column.

<https://standards.iteh.ai/catalog/standards/sist/1c9b2ccc-8387-474c-925b-6de3d3712a48/sist-en-3645-001-2009>
 (standards.iteh.ai)

EN 3645-001:2007 (E)

6.2 Plug mating dimensions

The mating dimensions of plugs are shown in Figure 2 and detail X in details V and W of Figure 1 and in Tables 2 and 3.

Dimensions and tolerances are in millimetres

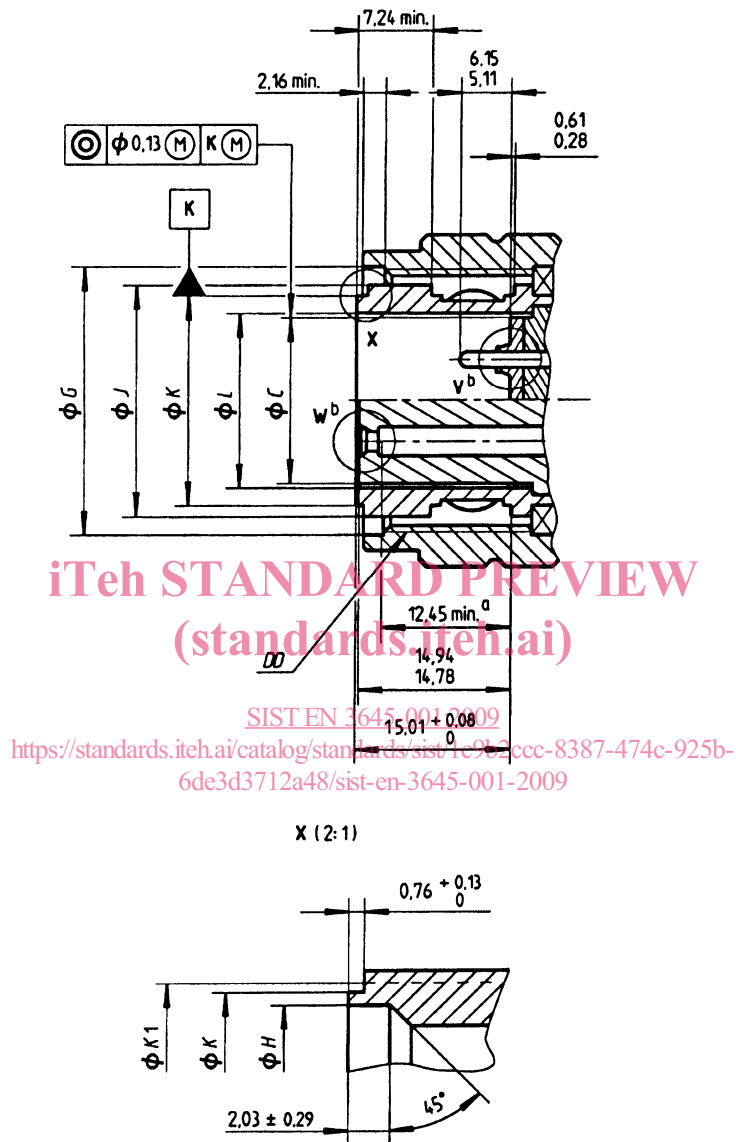

^a The distance between the shell shoulder and the point where the right end of a gauge with a diameter equal to the nominal diameter of a male contact comes into contact with the elastic part of the female contact.

^b V and W: see Figure 1.

Figure 2

Table 4

Housing size	C +0,13 -0,25	G +0,25 -0,03	H +0,13 -0,03	J	K	K	L min.
09	7,24	16,51	9,83	12,27 11,99	10,59	11,13 10,97	7,92
11	10,49	19,69	13,06	15,52 15,24	13,84	14,38 14,22	10,92
13	13,39	22,86	15,95	19,31 19,02	16,68	17,22 17,07	13,81
15	16,56	26,04	19,13	22,48 22,20	19,86	20,40 20,24	16,99
17	19,74	30,89	22,30	25,66 25,37	23,03	23,57 23,42	20,16
19	22,00	32,49	24,69	28,32 28,04	25,70	26,24 26,09	22,42
21	25,17	35,66	27,86	31,50 31,22	28,87	29,42 29,26	25,60
23	28,35	38,84	31,04	34,67 34,39	32,05	32,59 32,44	28,77
25	31,52	42,01	34,21	37,85 37,57	35,22	35,77 35,61	31,92

iTeh STANDARD PREVIEW
(standards.iteh.ai)

Table 5

DD — Thread									
Housing size	Designation ^a Class 2B thread			Internal thread Class 2B					
	Thread size inch	Apparent pitch	Actual pitch	Internal diameter		Diameter on side		Diameter at thread end	
				max.	min.	max.	min.	max.	min.
09	0,6250	0,100	0,300	14,96	14,71	15,46	15,21	16,38	15,97
11	0,7500			18,14	17,88	18,64	18,38	19,55	19,15
13	0,8750			21,31	21,06	21,81	21,56	22,73	22,32
15	1,0000			24,49	24,23	24,99	24,73	25,90	25,50
17	1,1875			28,94	28,63	29,60	29,29	30,77	30,26
19	1,2500			30,53	30,22	31,19	30,88	32,35	31,85
21	1,3750			33,70	33,40	34,36	34,06	35,53	35,02
23	1,5000			36,88	36,57	37,54	37,23	38,70	38,20
25	1,6250			40,05	39,75	40,71	40,41	41,88	41,37

^a According to MIL-STD-1373.