



**SLOVENSKI STANDARD**  
**SIST ISO 9591:1999**

**01-oktober-1999**

---

**Korozija aluminijevih zlitin - Ugotavljanje odpornosti pred pokanjem zaradi napetostne korozije**

Corrosion of aluminium alloys -- Determination of resistance to stress corrosion cracking

Corrosion des alliages d'aluminium -- Détermination de la résistance à la corrosion fissurante sous contrainte

**iTeh STANDARD PREVIEW**  
**(standards.iteh.ai)**

**Ta slovenski standard je istoveten z: ISO 9591:1992**

SIST ISO 9591:1999  
<https://standards.iteh.ai/catalog/standards/sist/d227f8eb-c5e5-4b41-af0f-bcf8ee9df8f8/sist-iso-9591-1999>

---

**ICS:**

77.060

Korozija kovin

Corrosion of metals

**SIST ISO 9591:1999**

**en**

**iTeh STANDARD PREVIEW**  
**(standards.iteh.ai)**

SIST ISO 9591:1999

<https://standards.iteh.ai/catalog/standards/sist/d227f8eb-c5e5-4b41-af0f-bcf8ee9df8f8/sist-iso-9591-1999>

# INTERNATIONAL STANDARD

**ISO**  
**9591**

First edition  
1992-02-15

---

---

## Corrosion of aluminium alloys — Determination of resistance to stress corrosion cracking

**iTeh STANDARD PREVIEW**

*Corrosion des alliages d'aluminium — Détermination de la résistance à  
la corrosion fissurante sous contrainte*  
(standards.iteh.ai)

SIST ISO 9591:1999

<https://standards.iteh.ai/catalog/standards/sist/d227f8eb-c5e5-4b41-af0f-bcf8ee9df8f8/sist-iso-9591-1999>



Reference number  
ISO 9591:1992(E)

## ISO 9591:1992(E)

**Foreword**

ISO (the International Organization for Standardization) is a worldwide federation of national standards bodies (ISO member bodies). The work of preparing International Standards is normally carried out through ISO technical committees. Each member body interested in a subject for which a technical committee has been established has the right to be represented on that committee. International organizations, governmental and non-governmental, in liaison with ISO, also take part in the work. ISO collaborates closely with the International Electrotechnical Commission (IEC) on all matters of electrotechnical standardization.

Draft International Standards adopted by the technical committees are circulated to the member bodies for voting. Publication as an International Standard requires approval by at least 75 % of the member bodies, casting a vote.

International Standard ISO 9591 was prepared by Technical Committee ISO/TC 156, *Corrosion of metals and alloys*.

Annex A forms an integral part of this International Standard.

iteh STANDARD PREVIEW  
(standards.iteh.ai)  
SIST ISO 9591:1999  
<https://standards.iteh.ai/catalog/standards/sist/d227f8eb-c5e5-4b41-af0f-bcf8ee9df8f8/sist-iso-9591-1999>

© ISO 1992

All rights reserved. No part of this publication may be reproduced or utilized in any form or by any means, electronic or mechanical, including photocopying and microfilm, without permission in writing from the publisher.

International Organization for Standardization  
Case Postale 56 • CH-1211 Genève 20 • Switzerland

Printed in Switzerland

# Corrosion of aluminium alloys — Determination of resistance to stress corrosion cracking

## 1 Scope

**1.1** This International Standard specifies a method for the determination of resistance to stress corrosion cracking (SCC) of aluminium alloys.

**1.2** This International Standard covers the method of sampling, the types of specimens, the loading procedure, the type of environment and the interpretation of results.

**1.3** This International Standard is aimed at the determination of the resistance to SCC as a function of the chemical composition, the method of manufacture and heat treatment of aluminium alloys.

**1.4** This International Standard applies to cast and wrought aluminium alloys in the form of castings, semi-finished products, parts and weldments.

**1.5** Since most natural and many artificial environments contain chlorides, this International Standard can be used to compare the performance of products employed under marine atmospheres and in environments containing chlorides providing that the failure mechanism is not changed. However, the results of this test should not be considered as an absolute criterion for the quality of alloys.

## 2 Normative references

The following standards contain provisions which, through reference in this text, constitute provisions of this International Standard. At the time of publication, the editions indicated were valid. All standards are subject to revision, and parties to agreements based on this International Standard are encouraged to investigate the possibility of applying the most recent editions of the standards indicated below. Members of IEC and ISO maintain registers of currently valid International Standards.

ISO 7539-1:1987, *Corrosion of metals and alloys — Stress corrosion testing — Part 1: General guidance on testing procedures.*

ISO 7539-2:1989, *Corrosion of metals and alloys — Stress corrosion testing — Part 2: Preparation and use of bent-beam specimens.*

ISO 7539-3:1989, *Corrosion of metals and alloys — Stress corrosion testing — Part 3: Preparation and use of U-bend specimens.*

ISO 7539-4:1989, *Corrosion of metals and alloys — Stress corrosion testing — Part 4: Preparation and use of uniaxially loaded tension specimens.*

ISO 7539-5:1989, *Corrosion of metals and alloys — Stress corrosion testing — Part 5: Preparation and use of C-ring specimens.*

ISO 7539-6:1989, *Corrosion of metals and alloys — Stress corrosion testing — Part 6: Preparation and use of pre-cracked specimens.*

ISO 7539-7:1989, *Corrosion of metals and alloys — Stress corrosion testing — Part 7: Slow strain rate testing.*

## 3 Definitions

For the purposes of this International Standard, the definitions given in ISO 7539-1 apply.

## 4 General principles

**4.1** This International Standard specifies two methods of loading:

- under constant total strain;
- under constant load.

**ISO 9591:1992(E)**

It does not cover slow strain rate test methods and determination of maximum admissible stress by the method of permanent deformation for aluminium alloys, although an effort is now being made to apply such methods to these alloys (see ISO 7539-7).

**4.2** This International Standard specifies two methods of immersion in the solution:

- alternate immersion;
- continuous immersion (subject to agreement between the interested parties).

**4.3** The evaluation criteria for corrosion cracking of alloys are

$\sigma_{SCC}$	the threshold stress, which is the maximum stress under which no failure of the samples occurs during the fixed period of the test;
$\tau_{SCC}$	the time of failure, which is the moment of the appearance of the first visible crack (or under magnification up to $\times 30$ ) for specimens under constant strain.

**4.4** The selection of the method of loading, the value of stresses, corrosive environment and criteria of evaluation can be the subject of an agreement between the interested parties and should be defined by the test programme.

## 5 Apparatus and materials

### 5.1 Loading apparatus

Tensile stresses in the specimens are produced with yokes, stressing screws, springs, lever devices and special testing machines.

### 5.2 Construction materials

If in contact with the salt solution, they shall not be affected by the corrodent to such an extent that they can cause contamination of the solution and change its corrosiveness.

**5.2.1** Use of inert plastics or glass is recommended where feasible.

**5.2.2** Metallic components which are in contact with the solution should be made from corrosion-resistant alloys (e.g. titanium or stainless steel), or protected with a suitable corrosion-resistant coating that also satisfies 5.2.

### 5.3 Specimen holders

They should be designed to electrically insulate the specimens from each other and from any bare metal parts. When this is not possible, as in the case of certain stressing bolts or jigs, the bare metal contacting the specimen should be isolated from the corrodent by a suitable coating. Protective coatings should be of a type that will not leach inhibiting or accelerating ions or protective oils or leave any residue, e.g. vapour, on the non-coated portions of the specimen. In particular, coatings containing chromates should be avoided. It is recommended that all samples should be degreased after coating.

### 5.4 Apparatus for alternate immersion in solutions

**5.4.1** Any suitable mechanism may be used to accomplish the immersion portion of the cycle provided that:

- a) it achieves the specified rate of immersion and removal; and
- b) the apparatus is constructed of suitable inert materials.

The usual methods of alternate immersion are

- a) specimens are placed on a movable rack that is periodically lowered into a stationary tank containing the solution;
- b) specimens are placed on a corrosion wheel arrangement which rotates every 10 min through  $60^\circ$  and thereby passes the specimens through a stationary tank of solution;
- c) specimens are placed in a stationary tray open to the atmosphere and the solution is moved by air pressure, by a non-metallic pump, or by gravity drain from the reservoir to the tray.

**5.4.2** The rate of immersion and removal of the specimens from the solution should be as rapid as possible without jarring them. For purposes of standardization, an arbitrary limit shall be adopted such that no more than 2 min elapse from the time of immersion in the solution or exhibiting in the air.

## 6 Sampling

**6.1** In general, this International Standard specifies three specimen orientations for thick products and two for thin products. The orientation diagram is given in figure 1. In figure 1a), the first direction refers to the specimen axis and the second direction refers to the direction of crack growth.

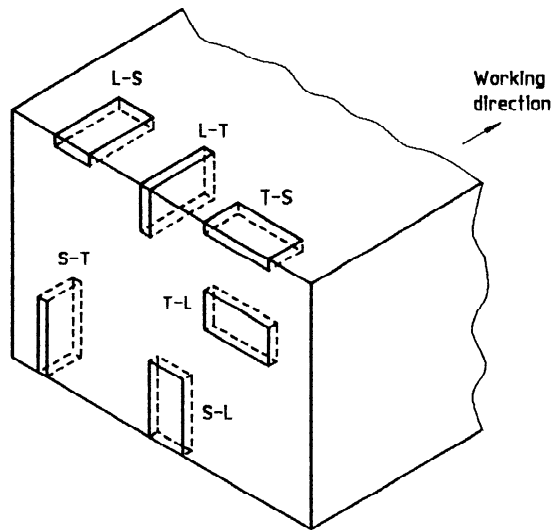

L-T Longitudinal-long transverse direction  
 L-S Longitudinal-short transverse direction  
 T-L Long transverse-longitudinal direction  
 T-S Long transverse-short transverse direction  
 S-L Short transverse-longitudinal direction  
 S-T Short transverse-long transverse direction

a) General procedure

iTeh STANDARD PREVIEW  
 (standards.iteh.ai)

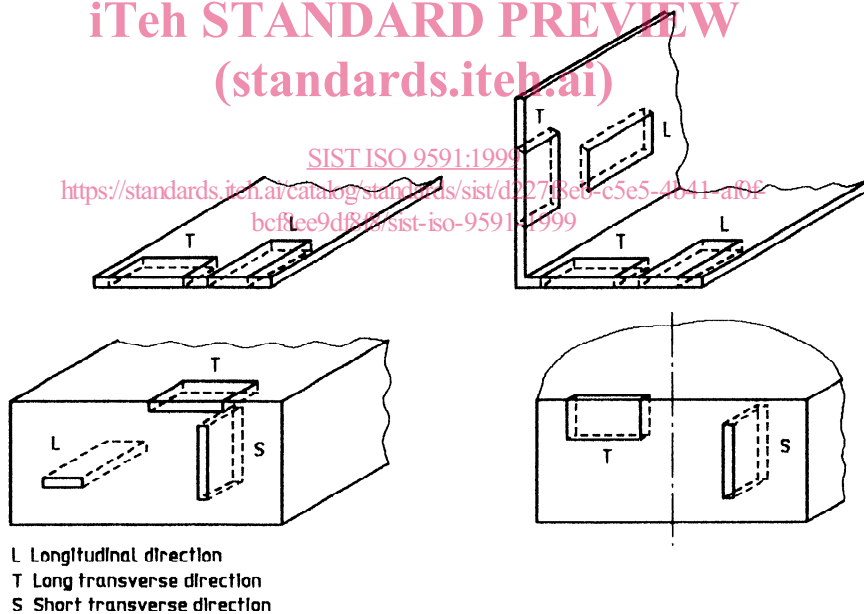

L Longitudinal direction  
 T Long transverse direction  
 S Short transverse direction

b) Recommended procedure

Figure 1 — Specimen orientation

## ISO 9591:1992(E)

**6.2** Unless otherwise specified, tests should be performed in the short transverse direction (S) for thick products and in the long transverse direction (T) for thin products. In rolled or extruded sections that are approximately round or square, the samples should be oriented in the transverse (diametrical) direction.

In the case of forgings and, more generally, when the structure of the test pieces is not obvious, it is recommended that the grain direction be determined by macroetching or by metallographic examination, in order to select specimens in the most susceptible (short transverse or long transverse) directions (see annex A).

**6.3** The number of specimens to be submitted to testing should be agreed between the interested parties, but for each case at one stress level it is recommended that no less than four adjacent specimens shall be tested, and at several testing levels, no less than three specimens.

## 7 Specimens

### 7.1 Type and sizes

Specimens as defined by ISO 7539-2 to ISO 7539-6 can be used.

**7.1.1** Tension specimens, C-ring specimens or bend specimens can be taken from thick products, for example from plates or forgings.

**7.1.2** Tension specimens, bent beam specimens or U-bend specimens can be taken from thin products, for example from sheets.

**7.1.3** When specimens are taken from weldments where the weld is perpendicular to the stress axis, the weld should be placed in the middle of the specimen.

**7.1.4** The comparison of different alloys and tempers should be conducted on specimens of the same type and size. Where possible, specimens should be heat treated before final machining, otherwise consideration must be given to the removal of oxidation products from the surface (see 7.2.4).

### 7.2 Surface preparation

**7.2.1** Specimens with surface defects (of mechanical or metallurgical origin) should be discarded.

**7.2.2** The surface quality of a specimen should comply with the following:

- without mechanical machining, in the as-supplied condition;

- with mechanical machining: the arithmetical mean deviation of the profile ( $R_a$ ) less than or equal to  $1 \mu\text{m}$  is recommended, unless it is required to simulate an as-manufactured surface condition;
- the surface condition of welded specimens should be agreed between the interested parties.

**7.2.3** Machining practices should not alter the metallurgical structure of the specimens and should be designed to minimize the generation of residual stresses.

**7.2.4** Test specimens should be degreased with an organic solvent (e.g. petroleum ether or acetone). Alternative surface treatments, for example pickling or etching, may be agreed between the interested parties. However, it should be recognized that chemical treatments may induce crack initiation in some tempers and alloys. In this case chemical treatment is not recommended.

### 7.3 Specimen identification

Specimens should be identified by a suitable method (see ISO 7539-1) and the markings should be protected against corrosion.

### 7.4 Precautions

After degreasing or pickling, the test region of the specimens should not be touched prior to testing.

## 8 Test environments

The test environment should be relevant to the intended application. Unless otherwise agreed, the following environments are recommended.

**8.1** Analytical grade chemicals are recommended for the preparation of the corrosive solutions.

**8.2** The solution should be prepared using distilled or deionized water. The minimum resistivity should be  $10^5 \Omega \cdot \text{cm}$ .

**8.3** For alternate immersions, an aqueous 3,5 % (m/m)  $\pm$  1 % (m/m) sodium chloride solution should be used. The pH of this solution, when freshly prepared for the test, shall be between 6,4 and 7,2, following adjustment, if necessary (see 8.5).

**8.4** For continuous immersion, an aqueous solution 2,0 % (m/m)  $\pm$  0,1 % (m/m) sodium chloride and 0,5 % (m/m)  $\pm$  0,05 % (m/m) sodium chromate ( $\text{Na}_2\text{CrO}_4$ ) should be used.

The pH of this solution should be adjusted to within  $3,0 \pm 0,2$  with hydrochloric acid. The pH should be



checked regularly during the test and adjusted, if necessary (see 8.5).

**8.5** Only diluted hydrochloric acid or sodium hydroxide solution should be used to adjust the pH of test solutions.

**8.6** The temperature and humidity of the laboratory should be controlled to ensure that the samples dry out between consecutive immersion periods during alternate immersion testing.

The relative humidity of the air should be controlled and maintained between 40 % and 75 %.

A temperature of  $25\text{ °C} \pm 3\text{ °C}$  is recommended to ensure the reproducibility of results.

**8.7** Before the freshly prepared solution is used, its temperature should be within  $3\text{ °C}$  of the specified air temperature. Thereafter, no control of the solution temperature is required. Instead, the ambient temperature is controlled and the solution is allowed to reach temperature equilibrium.

**8.8** The minimum ratio between the volume of test solution and the exposed area of specimens (including any uncoated accessories made from aluminium alloys) should be  $35\text{ ml/cm}^2$  for alloys exposed under alternate immersion conditions, and  $10\text{ ml/cm}^2$  for alloys exposed under continuous immersion conditions in sodium chloride/sodium chromate solution.

**8.9** Evaporation losses should be made up by daily additions of water of the required purity (see 8.2).

**8.10** Fresh solution should be prepared weekly. At the same time, the portions of the apparatus in contact with the solution should be cleaned by flushing with water.

## 9 Stress considerations

The loads should be such that the stresses are elastic. The elastic stresses are calculated from the equations given in ISO 7539-2 to ISO 7539-5.

## 10 Procedure

**10.1** The specimens should be exposed to the test environment as soon as possible after stressing.

**10.2** During alternate immersion, the specimens are totally immersed in the sodium chloride solution for 10 min of each hour and then removed from the solution and allowed to dry for 50 min.

A mild circulation of air is recommended and stagnant air conditions should be avoided.

Drying by forced air blast on the specimens is not recommended because of the difficulty in maintaining uniform drying of large groups of specimens.

The tests are usually carried out without interruption during a given exposure time.

**10.3** The test duration will depend upon the composition and heat treatment of the alloy, the specimen size, the environment and the method of stressing. Usually, test durations of between 10 days and 90 days are employed.

When the purpose of the test is to control the quality of production lots or to determine the characteristics laid down in the standard documents concerning alloys, the test duration shall be as required in pertinent specifications or shall form the subject of an agreement between the interested parties.

**10.4** It is forbidden to test simultaneously specimens of dissimilar alloy composition in the same salt solution.

For maximum reproducibility, do not expose specimens of low alloy content to the solution used for specimens of high alloy content if the alloying element differs appreciably from the base metal in the galvanic series in salt water. For example, specimens of copper-free aluminium alloys should not be exposed with specimens from alloys containing more than about 0,5 % copper.

**10.5** After exposure, unfailed specimens under constant strain should be unloaded, rinsed with water, and then cleaned in concentrated nitric acid (60 % to 70 %) at room temperature to remove corrosion products. They should then be rinsed with water and dried prior to more detailed examination.

## 11 Assessment of results

**11.1** Test specimens exposed under constant strain, which show questionable corrosion after cleaning, may require metallographic examination. For specimens under constant load, a metallographic examination may be used for failures occurring after more than 10 days, to check if failure is due to stress corrosion or to another form of corrosion. A specimen that reveals only transgranular pitting corrosion or pitting plus ductile failure shall not be considered as an SCC failure.

**11.2** Optical metallographic examination of a cross-section may be used to distinguish between stress corrosion, intergranular corrosion and transgranular pits. A specimen that reveals intergranular cracks deeper than transgranular pits shall be considered as an SCC failure. Intergranular corrosion not deeper than transgranular pits shall not be considered as an SCC failure.