



Designation: E 580 – 02

Standard Practice for Application of Ceiling Suspension Systems for Acoustical Tile and Lay-in Panels in Areas Requiring Seismic Restraint¹

This standard is issued under the fixed designation E 580; the number immediately following the designation indicates the year of original adoption or, in the case of revision, the year of last revision. A number in parentheses indicates the year of last reapproval. A superscript epsilon (ϵ) indicates an editorial change since the last revision or reapproval.

This standard has been approved for use by agencies of the Department of Defense.

1. Scope

1.1 This practice covers acoustical ceiling suspension systems and their additional requirements for application in areas subject to light to moderate seismic disturbance such as Uniform Building Code Seismic Zone 2, the BOCA Basic National Building Code where A_v is less than 0.20 but greater than 0.10, and the Standard Building Code (SBC) where A_v is less than 0.20 but greater than 0.05. This practice also covers areas subject to moderate to severe seismic disturbance such as Uniform Building Code Seismic Zones 3 and 4, the BOCA Basic National Building Code where A_v is greater than 0.20, and the SBC where A_v is greater than 0.20. The application of this practice is to be determined by local authorities. Current seismic maps published by recognized authorities such as those previously mentioned, should be consulted. Related material such as Open File 82-1033² and MS-812 Seismicity Map³ may also be consulted.

1.2 Specification C 635 and Practice C 636 cover suspension systems and their application without special regard to seismic restraint needs. They remain applicable and should be followed when this practice is specified.

1.3 This practice is not intended to stifle research and development of new products or methods which may simplify this specified application method. A variation, however, must be substantiated by verifiable engineering data.

1.4 A ceiling area of 144 ft² (13.4 m²) or less, surrounded by walls that connect directly to the structure above shall be exempt from this practice.

1.5 *This standard does not purport to address all of the safety concerns, if any, associated with its use. It is the responsibility of the user of this standard to establish appropriate safety and health practices and determine the applicability of regulatory limitations prior to use.*

¹ This practice is under the jurisdiction of ASTM Committee E33 on Environmental Acoustics and is the direct responsibility of Subcommittee E33.04 on Application.

Current edition approved April 10, 2002. Published July 2002. Originally published as E 580 – 76. Last previous edition E 580 – 00.

² Open File 82-1033 Probabilistic Estimate of Maximum Acceleration in Rock published by United States Geological Survey.

³ MS-8125 Seismicity Map of the Conterminous United States and Adjacent Areas, 1965–1974 published by United States Geological Survey.

2. Referenced Documents

2.1 ASTM Standards:

C 635 Specification for the Manufacture, Performance, and Testing of Metal Suspension Systems for Acoustical Tile and Lay-in Panel Ceilings⁴

C 636 Practice for Installation of Metal Ceiling Suspension Systems for Acoustical Tile and Lay-in Panels⁴

2.2 Other Standards:

National Electric Code, 1993⁵

Uniform Building Code, 1994⁶

BOCA Basic Building Code, 1993⁷

3. Areas Subject to Light to Moderate Seismic Disturbance

3.1 Suspension System Components:

3.1.1 The actual average weight of the ceiling system, including grid, panel or tile, light fixtures, and air terminals must be 2.5 lb/ft² (12.2 kg/m²) or less. All other services must be supported independently from the ceiling system. For ceilings that have an average weight greater than 2.5 lb/ft², the ceiling may be installed as specified in Section 4. Other deviations or variations must be substantiated by verifiable engineering data.

3.1.2 The main runners and cross runners of the ceiling system and their splices, intersection connectors, and expansion devices shall be designed and constructed to carry a mean ultimate test load of not less than 60 lb (27.2 kg) in tension with a 5° misalignment of the members in any direction and in compression. Instead of a 5° misalignment, the load may be applied with a 1-in. (25.4-mm) eccentricity on a sample not more than 24 in. (609 mm) long on each side of the splice.

3.1.3 Evaluation of test results shall be made on the basis of the mean values resulting from tests of not fewer than three identical specimens, provided the deviation of any individual test result from the mean value does not exceed $\pm 10\%$.

⁴ Annual Book of ASTM Standards, Vol 04.06.

⁵ Available from National Fire Protection Association, Batterymarch Park, Quincy, MA 02269.

⁶ Available from International Conference of Building Officials, 5360 S. Workman Mill Rd., Whittier, CA 90601.

⁷ Available from Building Officials and Code Administrators International, 4051 W. Flossmoor Rd., Country Club Hills, IL 60477.

3.2 Suspension System Application:

3.2.1 All perimeter closure angles or channels shall provide a support ledge of approximately 7/8 in. (22.2 mm) or greater.

3.2.2 The end of a grid member (or tile) that rests on the ledge or molding shall have at least 3/8-in. (9.5-mm) clearance from an edge or wall as shown in Fig. 1. Reveal (shadow) edge wall closures should accommodate these clearances as shown in Fig. 2. Ends of main runners and cross members shall be tied together to prevent their spreading.

3.2.3 Direct concealed suspended ceiling systems shall have positively connected stabilizer struts or mechanically connected cross runner at a maximum spacing of 60 in. (1524 mm) perpendicular to the main runners (see Fig. 3). Stabilizer bars shall occur within 24 in. (609 mm) of each wall.

3.2.4 Suspension Wire Application:

3.2.4.1 Suspension wires of soft, annealed, galvanized steel wire shall not be smaller than No. 12 gage spaced at 4 ft (1219 mm) on center or No. 10 gage at 5 ft (1524 mm) on center along each main runner unless calculations justifying the increased spacing are provided.

3.2.4.2 Each vertical wire shall be attached to the ceiling suspension member and to the support above with a minimum of three turns with a connection device capable of carrying not less than a 100-lb (45.4-kg) allowable load.

3.2.4.3 Suspension wires shall not hang more than one in six out of plumb unless countersloping wires are provided.

3.2.4.4 Wires shall not attach to or bend around interfering material or equipment. A trapeze or equivalent device shall be used where obstructions preclude direct suspension. Trapeze suspensions shall be a minimum of back-to-back 1 1/4-in. (31.75 mm) cold-rolled channels for spans exceeding 48 in. (1219 mm).

3.2.4.5 For perimeter closure angles that provide a support ledge of less than 7/8 in. (22.2 mm), the terminal ends of each cross runner or main runner shall be independently supported within 8 in. (203 mm) from each wall or ceiling discontinuity as shown in Fig. 3. This support may be a No. 12-gage hanger wire or other support that prevents the grid from falling. This wire does not need to be vertical but should not have a slope greater than one in six out of plumb. A 3/8-in. (9.5-mm) grid end clearance from a wall should be maintained.

3.2.5 The intent of the preceding provisions is to provide an unrestrained ceiling system that will accommodate the move-

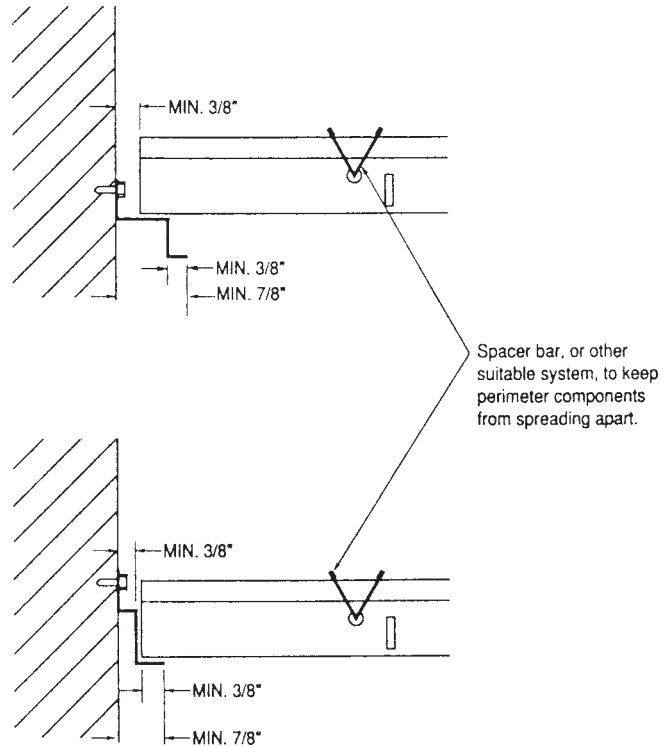

FIG. 2 Light to Moderate Treatment of Cross Runners and Main Runners at Terminal Ends When Using Reveal (Shadow) Edge Wall Closures

ment of the structure during a seismic event. The objective is to have a free-floating ceiling. Nothing may be installed which prevents the ceiling system from moving. All ceiling penetrations (columns, sprinklers, etc.) and independently supported fixtures or services are to be considered as perimeter closures that also must allow the noted clearances by using suitable escutcheons or closure details.

3.2.6 For essential facilities, perimeter support of each cross runner and main runner, as mentioned in 3.2.4.5, is required. In addition, a 1/2-in. (12.7-mm) grid end clearance from a wall should be maintained.

3.3 Light Fixture Application:

3.3.1 All lighting fixtures shall be positively attached to the suspended ceiling system by mechanical means as specified in the National Electrical Code, Section 410-16(c) unless independently supported. The attachment device, a minimum of two per fixture, shall have a capacity of 100 % of the lighting fixture weight acting in any direction.

3.3.2 Surface-mounted lighting fixtures shall be attached to the ceiling system with positive clamping devices that completely surround the supporting members. Safety wires shall be attached between the clamping device and the adjacent ceiling hanger or to the structure above. In no case shall the fixture exceed the design carrying capacity of the supporting members.

3.3.3 Pendant-hung lighting fixtures shall be supported directly from the structure above using No. 9-gage wire or an approved alternate support without using the ceiling suspension system for direct support.

3.3.4 Lighting fixtures weighing less than 56 lb (25.3 kg) shall have, in addition to the requirements outlined in 3.3, two

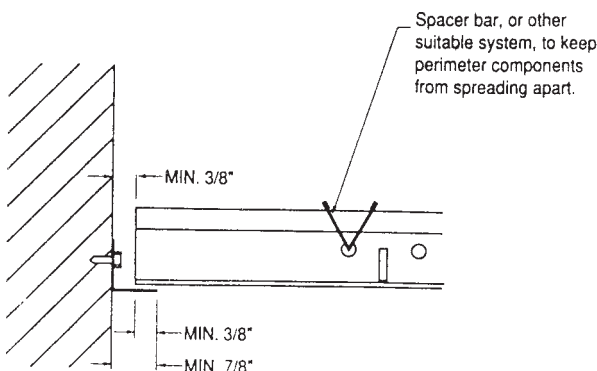

FIG. 1 Light to Moderate Treatment of Cross Runners, Main Runners, and Wall Closures at Terminal Ends