



Designation: E 803 – 91 (Reapproved 2002)

## Standard Test Method for Determining the $L/D$ Ratio of Neutron Radiography Beams<sup>1</sup>

This standard is issued under the fixed designation E 803; the number immediately following the designation indicates the year of original adoption or, in the case of revision, the year of last revision. A number in parentheses indicates the year of last approval. A superscript epsilon ( $\epsilon$ ) indicates an editorial change since the last revision or reapproval.

### 1. Scope

1.1 This test method defines an empirical technique for the measurement of the effective collimation ratio,  $L/D$ , of neutron radiography beams. The technique is based upon analysis of a neutron radiographic image and is independent of measurements and calculations based on physical dimensions of the collimator system. The values derived by this technique should be more accurate than those based on physical measurements, particularly for poorly defined apertures.

### 2. Referenced Documents

#### 2.1 ASTM Standards:

- E 748 Practices for Thermal Neutron Radiography of Materials<sup>2</sup>
- E 1316 Terminology for Nondestructive Examinations<sup>2</sup>

### 3. Summary of Test Method

3.1 Determination of neutron beam  $L/D$  ratio using the NU (no umbra) technique<sup>3</sup> is accomplished by radiographing the NU device with the neutron beam to be measured and subsequently analyzing the radiograph by one of three methods. Each of the three methods is based upon the determination of that point at which the umbral shadow width reaches zero. See Fig. 1. A key feature of the NU technique is that  $L/D$  can be determined accurately without the need for expensive instrumentation. Neutron radiography practices are discussed in Practices E 748 and the terms are defined in Terminology E 1316.

### 4. Significance and Use

4.1 The quality of a neutron radiographic image is dependent upon many factors. The  $L/D$  ratio is one of those factors

and constitutes a numerical definition of the geometry of the neutron beam. The  $L/D$  ratio required for a specific neutron radiographic examination is dependent upon the thickness of the specimen and the physical characteristics of the particular element of interest. Use of this test method allows the radiographer and the user to determine and periodically check the effective collimation ratio.

### 5. Apparatus

5.1 *NU Device* (see Figs. 2(a), 2(b), and 3) employs neutron absorbing rods positioned at various distances from the image plane. In practice this device consists of cadmium and nylon rods located in V-grooves accurately machined in the surface of an aluminum channel section set at a  $45 \pm 1/4^\circ$  angle to the side support plate. Near the image plane end the V-grooves are machined on 0.283-cm centers. After 21 V grooves, counting one on the end, the grooves are machined on 0.707-cm centers to the source end. The 0.64-mm diameter cadmium and nylon rods are laid into the V-grooves and secured with neutron transparent adhesive tape. The aluminum channel is supported by side plates to maintain the  $45 \pm 1/4^\circ$  angle relative to the image plane. While cadmium rods with diameters other than 0.64 mm may be used, the exact rod diameter must be known and the depth of the V grooves must be adjusted accordingly.

5.2 A single A unit as shown in Fig. 2(b) is used for  $L/D$  values expected to be less than 150. Alternately, a single A unit used with appropriate spacers may be used to accommodate a wide range of  $L/D$  values.

### 6. Procedure

6.1 Place the NU device against the cassette with the finely spaced rods nearest the cassette.

6.2 Align the plane of the cassette perpendicular to the axis of the neutron beam.

6.3 Expose the single-emulsion film and NU device for a time span that will produce a nominal background film density of  $2.5 \pm 0.4$ .

6.4 Process the exposed film in accordance with the manufacturer's recommendations.

6.5 Analyze the resultant image in accordance with one or more of the three methods outlined in Section 7.

<sup>1</sup> This test method is under the jurisdiction of Committee E07 on Nondestructive Testing and is the direct responsibility of Subcommittee E07.05 on Radiology (Neutron) Method.

Current edition approved May 15, 1991. Published July 1991. Originally published as E 803 – 86. Last previous edition E 803 – 86.

<sup>2</sup> *Annual Book of ASTM Standards*, Vol 03.03.

<sup>3</sup> Newacheck, R. L., and Underhill, P. E., "The NU Method for Determining  $L/D$  Ratio Of Neutron Radiography Facilities," Aerotest Operations, Inc., Report A.O. 77-27, June 1977.

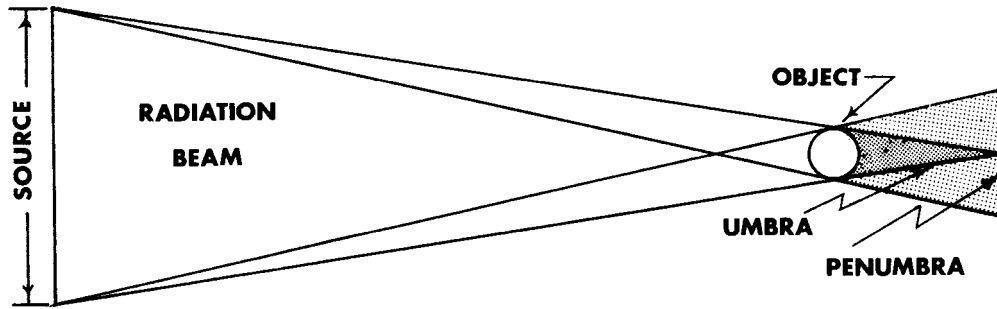
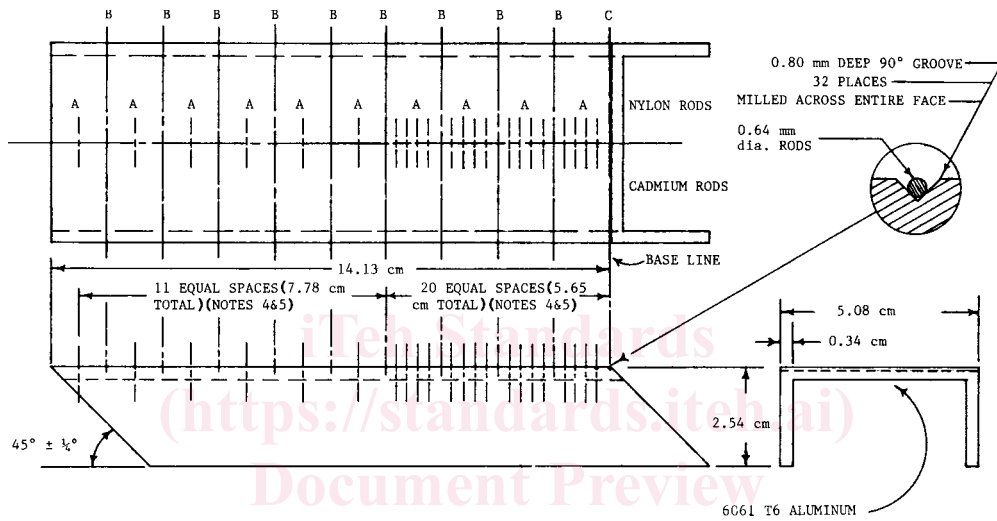

FIG. 1 Diagram of Zero Umbra Image Configuration



NOTE 1—Rods at “A” positions are 1 cm each side of center line (22 ea.)

NOTE 2—Rods at “B” positions are 2 cm each side of center line (9 ea.)

NOTE 3—Rods at “C” positions are 2.5 cm each side of center line (1 ea.)

NOTE 4—All dimensions from base line to reduce accumulative errors

NOTE 5—Rod arrangement shown for single system device. For an add-on device, to form a double system, extend the 11 spaces for 7.78 cm to 19 spaces for 13.43 cm and eliminate the close spacing (20 for 5.65 cm)

NOTE 6—Rods held tightly in position with one layer of transparent tape

2(a) Support Channel Subassembly with Rod Spacing

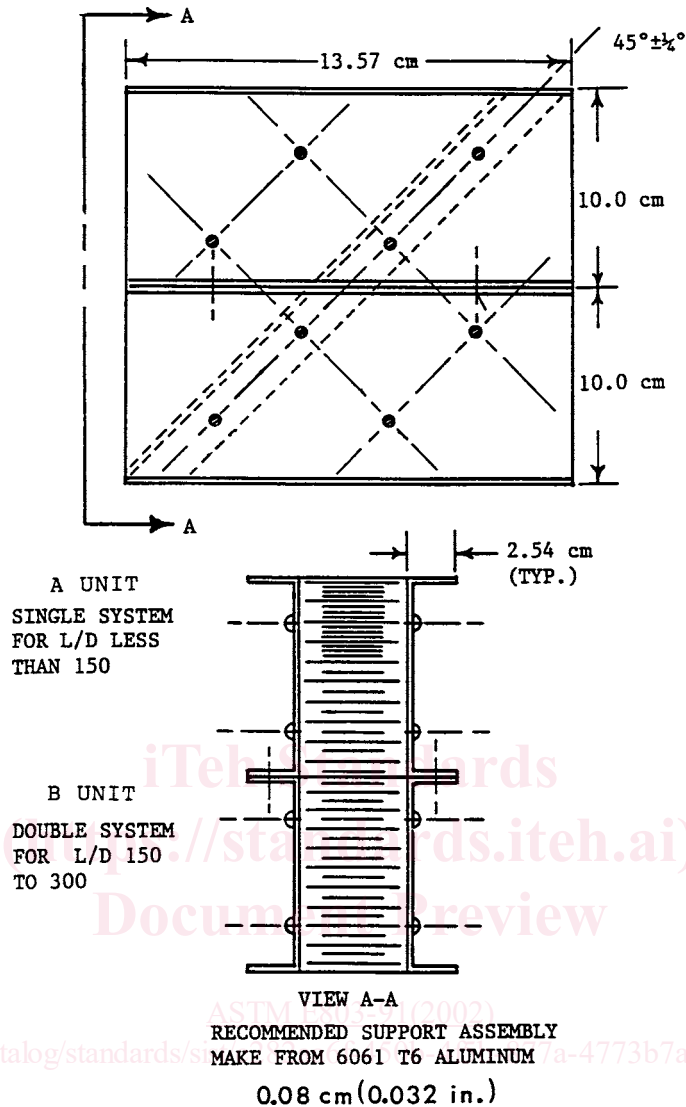

2(b) L/D Apparatus Assembly

## 7. Data Analysis

7.1 *Visual Analysis*—A visual determination of the  $L/D$  ratio can be made directly from the neutron radiograph. When observing the individual rod images, the umbral image can be recognized as the “white” line along the center of the rod image. This “white” line will decrease in width for the rods located farther and farther from the film. At some point the umbral images will disappear. Beyond this point a less intense white line will appear and increase in width with increasing rod distance. Use of a 5 to 10-power magnifier will aid in determining the point at which the “white” line disappears and then increases in width with a decreased intensity. Based on the visual observation, determine the rod with zero umbral width and then determine its distance ( $b$ ) from the cassette. The  $L/D$  ratio is as follows:

$$L/D = (b/\text{rod diameter})$$

7.2 *Microdensitometric Analysis*—The second data analysis method is based on a microdensitometric scan across the cadmium rod images beginning with the “0” position rod nearest the film. A typical scan is shown in Fig. 4. A densitometer aperture of  $20 \times 300 \mu\text{m}$  and no horizontal expansion is suggested for this method. The value of  $b$  is obtained from the intersection of a straight line originating from the tip (low film density) of the scan of the “0” rod and a curved line through the tips of the remaining wave forms as shown in Fig. 4. This method gives the best results for  $L/D$  ratios up to a few hundred. Higher  $L/D$  ratios cannot be determined by this method due to the inability to obtain a stable wave form for large values of  $b$ .

7.3 *Alternative Microdensitometric Analysis*—This method also uses scanning microdensitometric traces for  $L/D$  ratio determinations and is applicable for both high and low  $L/D$  ratios. For this method the recommended microdensitometer