

# TECHNICAL SPECIFICATION

**Marine energy – Wave, tidal and other water current converters –  
Part 1: Terminology**

(<https://standards.iteh.ai>)  
Document Preview

IEC TS 62600-1:2011

<https://standards.iteh.ai/catalog/standards/iec/153dd09-2483-4148-af34-54f44e50ffd8/iec-ts-62600-1-2011>

Withhold



## THIS PUBLICATION IS COPYRIGHT PROTECTED

Copyright © 2011 IEC, Geneva, Switzerland

All rights reserved. Unless otherwise specified, no part of this publication may be reproduced or utilized in any form or by any means, electronic or mechanical, including photocopying and microfilm, without permission in writing from either IEC or IEC's member National Committee in the country of the requester.

If you have any questions about IEC copyright or have an enquiry about obtaining additional rights to this publication, please contact the address below or your local IEC member National Committee for further information.

Droits de reproduction réservés. Sauf indication contraire, aucune partie de cette publication ne peut être reproduite ni utilisée sous quelque forme que ce soit et par aucun procédé, électronique ou mécanique, y compris la photocopie et les microfilms, sans l'accord écrit de la CEI ou du Comité national de la CEI du pays du demandeur.

Si vous avez des questions sur le copyright de la CEI ou si vous désirez obtenir des droits supplémentaires sur cette publication, utilisez les coordonnées ci-après ou contactez le Comité national de la CEI de votre pays de résidence.

IEC Central Office  
3, rue de Varembe  
CH-1211 Geneva 20  
Switzerland  
Email: [inmail@iec.ch](mailto:inmail@iec.ch)  
Web: [www.iec.ch](http://www.iec.ch)

### About IEC publications

The technical content of IEC publications is kept under constant review by the IEC. Please make sure that you have the latest edition, a corrigenda or an amendment might have been published.

- Catalogue of IEC publications: [www.iec.ch/searchpub](http://www.iec.ch/searchpub)

The IEC on-line Catalogue enables you to search by a variety of criteria (reference number, text, technical committee,...). It also gives information on projects, withdrawn and replaced publications.

- IEC Just Published: [www.iec.ch/online\\_news/justpub](http://www.iec.ch/online_news/justpub)

Stay up to date on all new IEC publications. Just Published details twice a month all new publications released. Available on-line and also by email.

- Electropedia: [www.electropedia.org](http://www.electropedia.org)

The world's leading online dictionary of electronic and electrical terms containing more than 20 000 terms and definitions in English and French, with equivalent terms in additional languages. Also known as the International Electrotechnical Vocabulary online.

- Customer Service Centre: [www.iec.ch/webstore/custserv](http://www.iec.ch/webstore/custserv)

If you wish to give us your feedback on this publication or need further assistance, please visit the Customer Service Centre FAQ or contact us:

Email: [csc@iec.ch](mailto:csc@iec.ch)  
Tel.: +41 22 919 02 11  
Fax: +41 22 919 03 00



<https://standards.iteh.ai/document/iec-ts-62600-1-2011>  
<https://standards.iec.org/15346d09-2483-4148-af34-54f44e50ffd8/iec-ts-62600-1-2011>

# TECHNICAL SPECIFICATION

---

**Marine energy – Wave, tidal and other water current converters –  
Part 1: Terminology**

(<https://standards.iteh.ai>)  
Document Preview

IEC TS 62600-1:2011

<https://standards.iteh.ai/standards/iec/153dd09-2483-4148-af34-54f44e50ffd8/iec-ts-62600-1-2011>

INTERNATIONAL  
ELECTROTECHNICAL  
COMMISSION

PRICE CODE

U

---

ICS 27.140

ISBN 978-2-88912-829-7

## CONTENTS

|                                                           |    |
|-----------------------------------------------------------|----|
| FOREWORD.....                                             | 3  |
| INTRODUCTION.....                                         | 5  |
| 1 Scope.....                                              | 6  |
| 2 Terms and definitions.....                              | 6  |
| Bibliography.....                                         | 26 |
| Figure 1 – Six degrees of freedom – Floating device.....  | 9  |
| Figure 2 – Six degrees of freedom – Submerged device..... | 9  |
| Figure 3 – Wave height and wave period.....               | 23 |

Withdrawing

iTech Standards  
(<https://standards.iteh.ai>)  
Document Preview

## INTERNATIONAL ELECTROTECHNICAL COMMISSION

**MARINE ENERGY –  
WAVE, TIDAL AND OTHER WATER CURRENT CONVERTERS –****Part 1: Terminology****FOREWORD**

- 1) The International Electrotechnical Commission (IEC) is a worldwide organization for standardization comprising all national electrotechnical committees (IEC National Committees). The object of IEC is to promote international co-operation on all questions concerning standardization in the electrical and electronic fields. To this end and in addition to other activities, IEC publishes International Standards, Technical Specifications, Technical Reports, Publicly Available Specifications (PAS) and Guides (hereafter referred to as "IEC Publication(s)"). Their preparation is entrusted to technical committees; any IEC National Committee interested in the subject dealt with may participate in this preparatory work. International, governmental and non-governmental organizations liaising with the IEC also participate in this preparation. IEC collaborates closely with the International Organization for Standardization (ISO) in accordance with conditions determined by agreement between the two organizations.
- 2) The formal decisions or agreements of IEC on technical matters express, as nearly as possible, an international consensus of opinion on the relevant subjects since each technical committee has representation from all interested IEC National Committees.
- 3) IEC Publications have the form of recommendations for international use and are accepted by IEC National Committees in that sense. While all reasonable efforts are made to ensure that the technical content of IEC Publications is accurate, IEC cannot be held responsible for the way in which they are used or for any misinterpretation by any end user.
- 4) In order to promote international uniformity, IEC National Committees undertake to apply IEC Publications transparently to the maximum extent possible in their national and regional publications. Any divergence between any IEC Publication and the corresponding national or regional publication shall be clearly indicated in the latter.
- 5) IEC itself does not provide any attestation of conformity. Independent certification bodies provide conformity assessment services and, in some areas, access to IEC marks of conformity. IEC is not responsible for any services carried out by independent certification bodies.
- 6) All users should ensure that they have the latest edition of this publication.
- 7) No liability shall attach to IEC or its directors, employees, servants or agents including individual experts and members of its technical committees and IEC National Committees for any personal injury, property damage or other damage of any nature whatsoever, whether direct or indirect, or for costs (including legal fees) and expenses arising out of the publication, use of, or reliance upon, this IEC Publication or any other IEC Publications.
- 8) Attention is drawn to the Normative references cited in this publication. Use of the referenced publications is indispensable for the correct application of this publication.
- 9) Attention is drawn to the possibility that some of the elements of this IEC Publication may be the subject of patent rights. IEC shall not be held responsible for identifying any or all such patent rights.

The main task of IEC technical committees is to prepare International Standards. In exceptional circumstances, a technical committee may propose the publication of a technical specification when

- the required support cannot be obtained for the publication of an International Standard, despite repeated efforts, or
- the subject is still under technical development or where, for any other reason, there is the future but no immediate possibility of an agreement on an International Standard.

Technical specifications are subject to review within three years of publication to decide whether they can be transformed into International Standards.

IEC 62600-1, which is a technical specification, has been prepared by IEC technical committee 114: Marine energy – Wave, tidal and other water current converters.

The text of this technical specification is based on the following documents:

|               |                  |
|---------------|------------------|
| Enquiry draft | Report on voting |
| 114/65/DTS    | 114/76/RVC       |

Full information on the voting for the approval of this technical specification can be found in the report on voting indicated in the above table.

This publication has been drafted in accordance with the ISO/IEC Directives, Part 2.

The committee has decided that the contents of this publication will remain unchanged until the stability date indicated on the IEC web site under "<http://webstore.iec.ch>" in the data related to the specific publication. At this date, the publication will be

- transformed into an International standard,
- reconfirmed,
- withdrawn,
- replaced by a revised edition, or
- amended.

A bilingual version of this publication may be issued at a later date.

iTech Standards  
(<https://standards.itih.ai>)  
Document Preview

IEC TS 62600-1:2011

<https://standards.itih.ai/standards/iec/15/dd09-2483-4148-af34-54f44e50ffd8/iec-ts-62600-1-2011>

## INTRODUCTION

This Technical Specification has been developed as a tool for the international marine energy community, to assist in creating clarity and understanding. The wave, tidal and water current energy industry has recently experienced a period of rapid growth and sector development. With this expansion, it became apparent that a glossary of terms for the sector was required. The aim of this Technical Specification is to present clear and consistent language that will aid the development of programs, projects, and future standards.

This Technical Specification lists the terms that the marine energy industry commonly uses. It is an evolving document that will change as new terms and symbols are added. The terminologies herein have been harmonized with IEC 60050 and other IEC documents as far as possible.

Withdrawing

iTech Standards  
(<https://standards.iteh.ai>)  
Document Preview

IEC TS 62600-1:2011  
<https://standards.iteh.ai/catalog/standards/iec/151dd09-2483-4148-af34-54f44e50ffd8/iec-ts-62600-1-2011>

# MARINE ENERGY – WAVE, TIDAL AND OTHER WATER CURRENT CONVERTERS –

## Part 1: Terminology

### 1 Scope

This part of IEC 62600 defines the terms relevant to ocean and marine renewable energy. For the purposes of this Technical Specification, sources of ocean and marine renewable energy are taken to include wave, tidal current, and other water current energy converters.

Terms relating to conventional dam and tidal barrage, offshore wind, marine biomass, ocean thermal and salinity gradient energy conversion are not included in the scope of this Technical Specification.

This Technical Specification is intended to provide uniform terminology to facilitate communication between organizations and individuals in the marine renewable energy industry and those who interact with them.

### 2 Terms and definitions

For the purposes of this document, the following terms and definitions apply.

#### 2.1

##### **added mass**

extra mass associated with the additional force necessary to accelerate a body through a fluid compared to the same acceleration in a vacuum

NOTE 1 In general, added mass is a variable that depends on the state of the unsteady motion and is not a constant.

NOTE 2 In a viscous (real) fluid, the added mass would include kinetic energy of a fluid layer entrained by the accelerating body.

#### 2.2

##### **added mass at infinity**

limit of the mass corresponding to the added mass as the frequency tends to infinity

NOTE The value of added mass at infinity is normally necessary for time domain modelling of wave-body interaction.

#### 2.3

##### **added mass coefficient**

ratio between added mass and the mass of the water displaced by the submerged body

#### 2.4

##### **amplitude control**

method to obtain the optimum oscillatory motion amplitude to capture a maximum of wave energy

NOTE For a simple oscillating system, the object of amplitude control is to obtain a given oscillatory velocity amplitude that should be related with the wave excitation force.



**2.5****annual energy production** (marine energy converter)

estimate of total energy production of a marine energy converter system during a one-year period obtained by applying its power performance assessment to a prospective marine energy resource characterization and assuming 100 % availability

NOTE Actual annual energy production is unlikely to exceed this estimate.

[IEC 60050-415:1999, 415-05-09, modified]

**2.6****array** (marine energy)

**farm** of marine energy converters arranged specifically so as to enhance energy capture

NOTE Array spacing is dictated by hydrodynamic considerations and may be very closely packed so as to constitute a single platform or an arrangement of identical devices.

**2.7****attenuator device**

energy converter which is aligned parallel to the predominant direction of wave incidence

**2.8****availability** (marine energy converter)

ability of a marine energy conversion system to be in a state to perform a necessary function under given conditions at a given instant of time or over a given duration, assuming that the necessary external resources are provided

NOTE 1 For continuously running equipment availability equates to:  $\text{uptime}/(\text{uptime} + \text{downtime})$ .

NOTE 2 Where reliability is specified in Mean Time Between Failures (MTBF) and maintainability in Mean Time To Repair (MTTR), availability also equates to:  $\text{MTBF}/(\text{MTBF} + \text{MTTR})$ .

[IEC 60050-191:1990, 191-02-05, modified]

**2.9****capture area** (tidal)

equal to the power captured by the hydrodynamically functional part of a TEC divided by power per square metre of the incident tidal stream

**2.10****capture length** (wave)

capture width

equal to the power captured by the hydrodynamically functional part of a WEC divided by power per metre of the incident wave field

**2.11****centre of buoyancy**

centroid of the submerged volume

**2.12****centre of flotation**

point coinciding with the centroid of the water-plane area

NOTE The water-plane area is the cross-sectional area of the floating body at mean water level in calm water.

**2.13****chart datum**

reference level of water, typically from a selected phase of the tide at a specific location

NOTE Different hydrographic organizations have differing conventions for defining chart datum.

**2.14**

**conversion efficiency (resource to wire)**

measure of the overall effectiveness of a marine energy converter calculated as the ratio of electrical power output in relation to the incident power in the water resource

NOTE 1 For WECs, conversion efficiency (resource to wire) is sometimes referred to as wave-to-wire conversion efficiency.

NOTE 2 Conversion efficiency (resource to wire) is normally calculated over extended periods (e.g. tidal cycle, years, etc.).

**2.15**

**current profile**

variation in velocity throughout the water column, typically displayed as a function of height above the sea bed

**2.16**

**deep water (offshore)**

spatial location where the depth of the water is greater than or equal to half the wave length

NOTE The deep water (offshore) spatial location is based on the kinematic properties of waves. The dispersion equation is

$$L = \frac{gT^2}{2\pi} \tanh \frac{2\pi d}{L}$$

where

- $L$  is the wave length;
- $d$  is the water depth;
- $T$  is the period;
- $g$  is the gravitation acceleration.

In deep water, the dispersion equation may be simplified to

$$L = \frac{gT^2}{2\pi} = 1,56 T^2$$

**2.17**

**degree of freedom**

independent displacements and/or rotations that specify the orientation of a body or system

NOTE 1 A marine body may experience three linear and three rotational motions as depicted in Figures 1 and 2.

NOTE 2 The principal axis is parallel to the mean water surface and aligned with the direction of incident energy, and the rotations act about the centre of gravity.

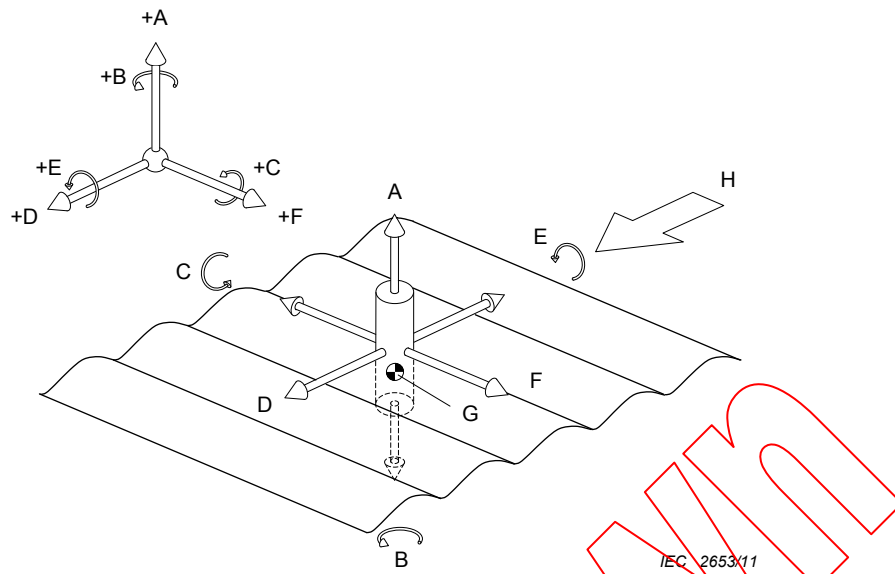

**Key**

- |   |       |   |       |   |                   |
|---|-------|---|-------|---|-------------------|
| A | Heave | D | Surge | G | Centre of gravity |
| B | Yaw   | E | Roll  | H | Incident energy   |
| C | Pitch | F | Sway  |   |                   |

**Figure 1 – Six degrees of freedom – Floating device**

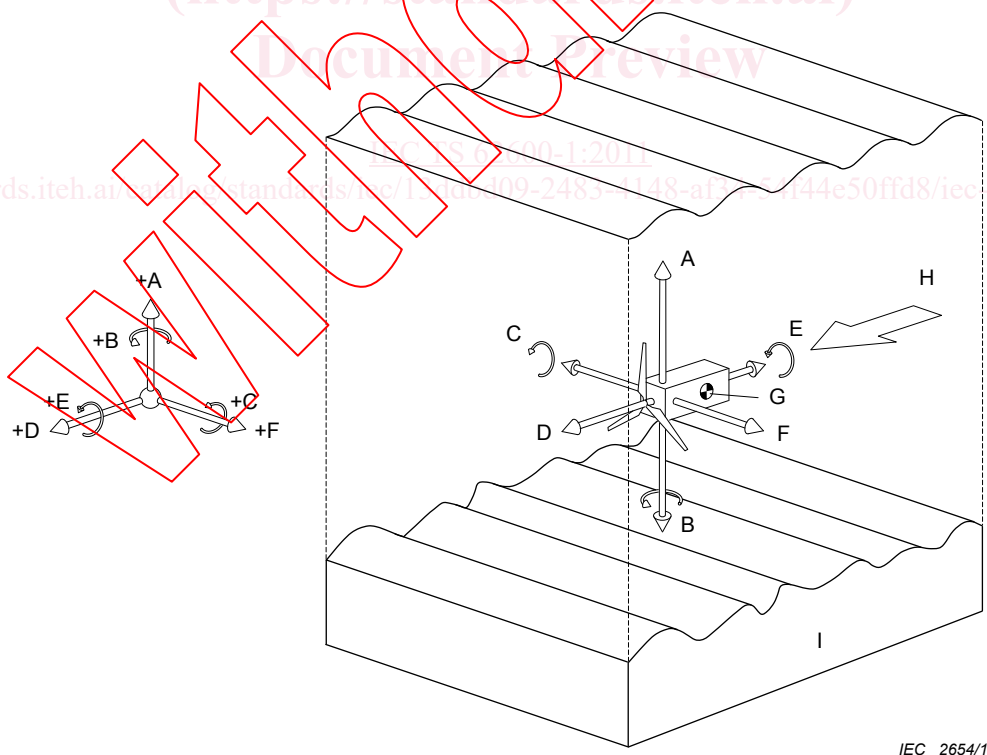

**Key**

- |   |       |   |       |   |                   |
|---|-------|---|-------|---|-------------------|
| A | Heave | D | Surge | G | Centre of gravity |
| B | Yaw   | E | Roll  | H | Incident energy   |
| C | Pitch | F | Sway  | I | Seabed            |

**Figure 2 – Six degrees of freedom – Submerged device**