



SLOVENSKI STANDARD
SIST EN 3475-504:2004
01-maj-2004

Aerospace series - Cables, electrical, aircraft use - Test methods - Part 504: Torsion

Aerospace series - Cables, electrical, aircraft use - Test methods - Part 504: Torsion

Luft- und Raumfahrt - Elektrische Leitungen für Luftfahrt, Verwendung - Prüfverfahren - Teil 504: Torsion

iTeh STANDARD PREVIEW

Série aérospatiale - Câbles électriques à usage aéronautique - Méthodes d'essai - Partie 504: Torsion

[SIST EN 3475-504:2004](https://standards.iteh.ai/catalog/standards/sist/9eedf6f-f28e-45a4-b6b5-50269b6826f1/sist-en-3475-504-2004)

Ta slovenski standard je istoveten z: EN 3475-504:2002

ICS:

49.060 Štejni inštrumenti in oprema za letalstvo in zrakoplovstvo
Aerospace electric equipment and systems

SIST EN 3475-504:2004 en

iTeh STANDARD PREVIEW
(standards.iteh.ai)

[SIST EN 3475-504:2004](https://standards.iteh.ai/catalog/standards/sist/9eedfe6f-f28e-45a4-b6b5-30209bb826f1/sist-en-3475-504-2004)

<https://standards.iteh.ai/catalog/standards/sist/9eedfe6f-f28e-45a4-b6b5-30209bb826f1/sist-en-3475-504-2004>

EUROPEAN STANDARD
NORME EUROPÉENNE
EUROPÄISCHE NORM

EN 3475-504

January 2002

ICS 49.060

English version

**Aerospace series - Cables, electrical, aircraft use - Test
methods - Part 504: Torsion**

Série aérospatiale - Câbles électriques à usage
aéronautique - Méthodes d'essai - Partie 504: Torsion

Luft- und Raumfahrt - Elektrische Leitungen für Luftfahrt,
Verwendung - Prüfverfahren - Teil 504: Torsion

This European Standard was approved by CEN on 6 August 2001.

CEN members are bound to comply with the CEN/CENELEC Internal Regulations which stipulate the conditions for giving this European Standard the status of a national standard without any alteration. Up-to-date lists and bibliographical references concerning such national standards may be obtained on application to the Management Centre or to any CEN member.

This European Standard exists in three official versions (English, French, German). A version in any other language made by translation under the responsibility of a CEN member into its own language and notified to the Management Centre has the same status as the official versions.

CEN members are the national standards bodies of Austria, Belgium, Czech Republic, Denmark, Finland, France, Germany, Greece, Iceland, Ireland, Italy, Luxembourg, Malta, Netherlands, Norway, Portugal, Spain, Sweden, Switzerland and United Kingdom.

[SIST EN 3475-504:2004](https://standards.iteh.ai/catalog/standards/sist/9eedfe6f-f28e-45a4-b6b5-30209bb826f1/sist-en-3475-504-2004)

<https://standards.iteh.ai/catalog/standards/sist/9eedfe6f-f28e-45a4-b6b5-30209bb826f1/sist-en-3475-504-2004>



EUROPEAN COMMITTEE FOR STANDARDIZATION
COMITÉ EUROPÉEN DE NORMALISATION
EUROPÄISCHES KOMITEE FÜR NORMUNG

Management Centre: rue de Stassart, 36 B-1050 Brussels

Foreword

This document (EN 3475-504:2002) has been prepared by the European Association of Aerospace Manufacturers (AECMA).

After enquiries and votes carried out in accordance with the rules of this Association, this Standard has received the approval of the National Associations and the Official Services of the member countries of AECMA, prior to its presentation to CEN

This European Standard shall be given the status of a national standard, either by publication of an identical text or by endorsement, at the latest by July 2002, and conflicting national standards shall be withdrawn at the latest by July 2002.

According to the CEN/CENELEC Internal Regulations, the national standards organizations of the following countries are bound to implement this European Standard : Austria, Belgium, Czech Republic, Denmark, Finland, France, Germany, Greece, Iceland, Ireland, Italy, Luxembourg, Malta, Netherlands, Norway, Portugal, Spain, Sweden, Switzerland and the United Kingdom.

1 Scope

This standard specifies a method of checking the resistance to damage under torsion of insulated conductors or finished cables.

It shall be used together with EN 3475-100.

2 Normative references

This European Standard incorporates by dated or undated reference provisions from other publications. These normative references are cited at the appropriate places in the text and the publications are listed hereafter. For dated references, subsequent amendments to or revisions of any of these publications apply to this European Standard only when incorporated in it by amendment or revision. For undated references the latest edition of the publication referred to applies.

EN 3475-100 Aerospace series – Cables, electrical, aircraft use – Test methods – Part 100: General

3 Preparation of a specimen

A specimen 250 mm long is pre-aged for 50 h in an oven at temperature T_4 (specified in the product standard).

iTeh STANDARD PREVIEW
(standards.iteh.ai)

4 Apparatus

SIST EN 3475-504:2004

<https://standards.iteh.ai/catalog/standards/sist/9eedfe6f-f28e-45a4-b6b5-9420900e2014/sist-en-3475-504-2004>

The apparatus shall consist basically of two clamps for the specimen, axially aligned and face to face, and at such a distance that the specimen is taut (see figure 1).

One of the clamps shall be able to turn 360° on both sides of the specimen axis, so that the effects of torsion and untwisting are applied on the taut test piece.

The other clamp shall be capable of movement parallel to the axis of the specimen, so that it is kept taut by means of a load defined in the technical specification. It shall not rotate.

The apparatus shall be placed in a chamber at temperature T_3 , specified in the product standard.

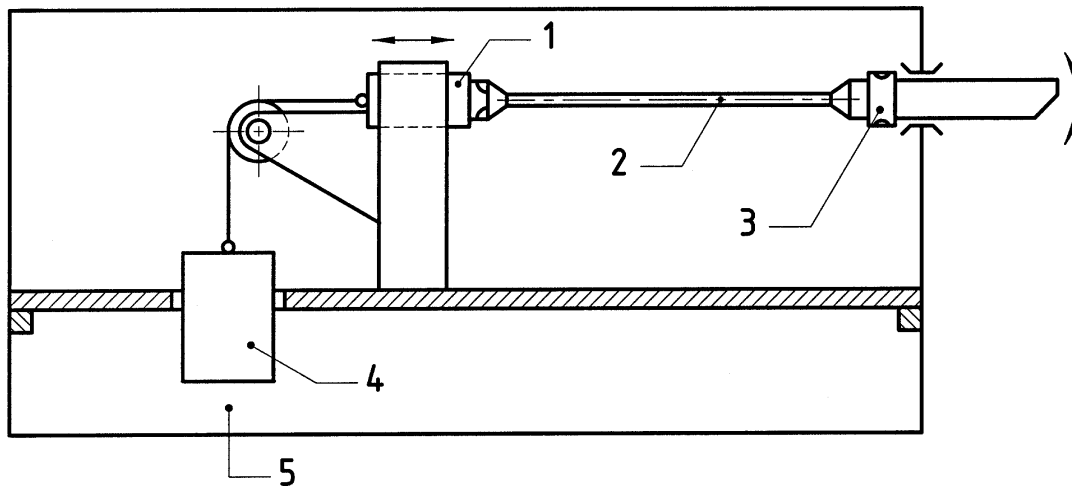
**Key**

- 1 Sliding attachment
- 2 Specimen
- 3 Rotating attachment
- 4 Counter-weight
- 5 Heating chamber

Figure 1 – General arrangement
 iTeh STANDARD PREVIEW
 (standards.iteh.ai)

5 Method

[SIST EN 3475-504:2004](https://standards.iteh.ai/catalog/standards/sist/9eedfe6f-f28e-45a4-b6b5-30209bb826f1/sist-en-3475-504-2004)

5.1 Procedure

<https://standards.iteh.ai/catalog/standards/sist/9eedfe6f-f28e-45a4-b6b5-30209bb826f1/sist-en-3475-504-2004>

The aged specimen shall be secured in the torsion apparatus and stretched by a load defined in the technical specification. The whole unit shall then be placed in a chamber brought up to a temperature T_3 and the torsion tests shall be carried out at this temperature.

Each torsion cycle corresponds to the rotation of the specimen 360° in one direction, then 720° in the other direction and once more 360° in the initial direction, bringing the specimen back to position zero.

5.2 Requirements

100 cycles shall be carried out in this manner at a speed of five to six cycles per minute.

The equipment shall then be removed from the heat chamber and the specimen from the attachment device. A visual inspection shall then be made of the specimen to detect any possible debonding from the insulation. Any debonding of layers either along the insulation or at the ends shall be considered as a defect.