Aerospace — Double-shank ball-ends, in corrosion-resistant steel, swaged on aircraft control wire rope — Dimensions and loads

Aéronautique et espace — Embouts à sphère centrale, en acier résistant à la corrosion, à sertir sur câbles de commande d'aéronefs — Dimensions et charges

(<https://standards.iteh.ai>)
Document Preview

[ISO 9747:2000](https://standards.iteh.ai/catalog/standards/iso/bd8af424-cda2-4be0-8ebd-e2d17b0b719c/iso-9747-2000)

<https://standards.iteh.ai/catalog/standards/iso/bd8af424-cda2-4be0-8ebd-e2d17b0b719c/iso-9747-2000>



PDF disclaimer

This PDF file may contain embedded typefaces. In accordance with Adobe's licensing policy, this file may be printed or viewed but shall not be edited unless the typefaces which are embedded are licensed to and installed on the computer performing the editing. In downloading this file, parties accept therein the responsibility of not infringing Adobe's licensing policy. The ISO Central Secretariat accepts no liability in this area.

Adobe is a trademark of Adobe Systems Incorporated.

Details of the software products used to create this PDF file can be found in the General Info relative to the file; the PDF-creation parameters were optimized for printing. Every care has been taken to ensure that the file is suitable for use by ISO member bodies. In the unlikely event that a problem relating to it is found, please inform the Central Secretariat at the address given below.

iTeh Standards
(<https://standards.iteh.ai>)
Document Preview

[ISO 9747:2000](https://standards.iteh.ai/catalog/standards/iso/bd8af424-cda2-4be0-8ebd-e2d17b0b719c/iso-9747-2000)

<https://standards.iteh.ai/catalog/standards/iso/bd8af424-cda2-4be0-8ebd-e2d17b0b719c/iso-9747-2000>

© ISO 2000

All rights reserved. Unless otherwise specified, no part of this publication may be reproduced or utilized in any form or by any means, electronic or mechanical, including photocopying and microfilm, without permission in writing from either ISO at the address below or ISO's member body in the country of the requester.

ISO copyright office
Case postale 56 • CH-1211 Geneva 20
Tel. + 41 22 749 01 11
Fax + 41 22 749 09 47
E-mail copyright@iso.ch
Web www.iso.ch

Printed in Switzerland

Foreword

ISO (the International Organization for Standardization) is a worldwide federation of national standards bodies (ISO member bodies). The work of preparing International Standards is normally carried out through ISO technical committees. Each member body interested in a subject for which a technical committee has been established has the right to be represented on that committee. International organizations, governmental and non-governmental, in liaison with ISO, also take part in the work. ISO collaborates closely with the International Electrotechnical Commission (IEC) on all matters of electrotechnical standardization.

International Standards are drafted in accordance with the rules given in the ISO/IEC Directives, Part 3.

Draft International Standards adopted by the technical committees are circulated to the member bodies for voting. Publication as an International Standard requires approval by at least 75 % of the member bodies casting a vote.

International Standard ISO 9747 was prepared by Technical Committee ISO/TC 20, *Aircraft and space vehicles*, Subcommittee SC 12, *Mechanical system parts*.

Annex A forms a normative part of this International Standard.

iTeh Standards
(<https://standards.itih.ai>)
Document Preview

[ISO 9747:2000](https://standards.itih.ai/catalog/standards/iso/bd8af424-cda2-4be0-8ebd-e2d17b0b719c/iso-9747-2000)

<https://standards.itih.ai/catalog/standards/iso/bd8af424-cda2-4be0-8ebd-e2d17b0b719c/iso-9747-2000>

Aerospace — Double-shank ball-ends, in corrosion-resistant steel, swaged on aircraft control wire rope — Dimensions and loads

1 Scope

This International Standard specifies the characteristics of double-shank ball-ends in corrosion-resistant steel swaged on aircraft control wire rope.

2 Normative references

The following normative documents contain provisions which, through reference in this text, constitute provisions of this International Standard. For dated references, subsequent amendments to, or revisions of, any of these publications do not apply. However, parties to agreements based on this International Standard are encouraged to investigate the possibility of applying the most recent editions of the normative documents indicated below. For undated references, the latest edition of the normative document referred to applies. Members of ISO and IEC maintain registers of currently valid International Standards.

ISO 2020-1:1997, *Aerospace — Preformed flexible steel wire rope for aircraft controls — Part 1: Dimensions and loads.*

ISO 8074:1985, *Aerospace — Surface treatment of austenitic stainless steel parts.*

ISO 10955:1999, *Aerospace — End fittings and turnbarrels for aircraft control wire rope — Technical specification.*

ISO 13715:2000, *Technical drawings — Edges of undefined shape — Vocabulary and indication on drawings.*

EN 2465:—¹⁾, *Aerospace series — Steel FE-PA11 — Softened — Bars $D_e \leq 100$ mm.*²⁾

SAE AMS 2431/6A, *Peening Media, Glass Shot.*

SAE AMS 5639G, *Steel, Corrosion Resistant, Bars, Wire, Forgings, Tubing and Rings, 19Cr 10Ni, Solution Heat Treated.*

SAE AMS 5641F, *Steel, Corrosion Resistant, Bars, Wire, and Forgings, 18.5Cr 10Ni 0.22Se Free-Machining; Swaging or Upsetting, Solution Heat Treated.*

3 Configuration, dimensions, loads and masses

Configuration, dimensions, loads and masses shall be in accordance with Figure 1 and Table 1.

¹⁾ To be published.

²⁾ AECMA.

Dimensions in millimetres
Surface roughness in micrometres

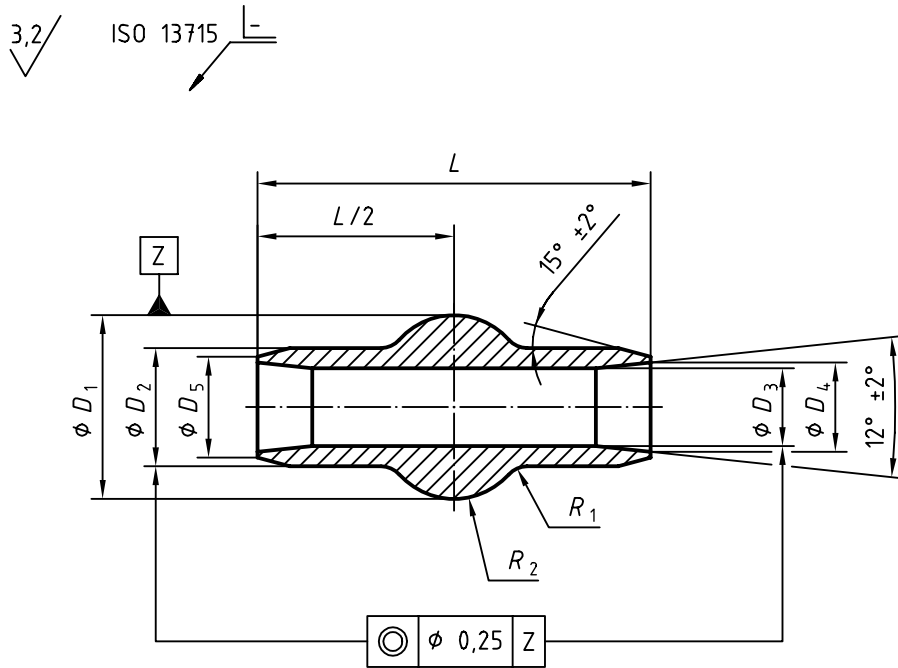

Figure 1

Table 1

Dimensions in millimetres

Wire rope ^a		D_1	D_2	D_3	D_4	D_5	L	R_1	R_2	Mass	Minimum breaking load ^a
Code	Nominal diameter		+0,1 0	+0,1 0	+0,1 0	0 -0,2	+0,5 0	$\pm 0,25$	$\pm 0,25$	g/piece ≈	kN
16	1,6	5,5	3,5	1,9	2,2	3	9	0,8	2	0,5	2,15
24	2,4	7	4,5	2,8	3	3,5	13	1	3	1,1	4,45
32	3,2	9	5,5	3,6	4	5	18	1,2	4	2,7	8,9
40	4	11	6,5	4,4	4,9	5,5	22	1,5		3,5	12,45
48	4,8	12,5	7,5	5,2	5,8	6,5	26	1,6	5	5,6	18,6
56	5,6	14	9	6	6,6	7,5	30	2		8,2	24,9
64	6,4	16	10	6,8	7,5	8,5	34		6	12,1	31,2

^a In accordance with ISO 2020-1