

INTERNATIONAL STANDARD

**ISO
9775**

First edition
1990-12-15

Small craft — Remote steering systems for single outboard motors of 15 kW to 40 kW power

iTeh STANDARD PREVIEW
*Navires de plaisance — Appareils à gouverner commandés à distance
pour moteurs hors-bord uniques de puissance comprise entre 15 kW et
40 kW*
(standards.iteh.ai)

ISO 9775:1990

<https://standards.iteh.ai/catalog/standards/sist/541c9624-8b12-4344-9119-a0e4ef829834/iso-9775-1990>



Reference number
ISO 9775:1990(E)

Foreword

ISO (the International Organization for Standardization) is a worldwide federation of national standards bodies (ISO member bodies). The work of preparing International Standards is normally carried out through ISO technical committees. Each member body interested in a subject for which a technical committee has been established has the right to be represented on that committee. International organizations, governmental and non-governmental, in liaison with ISO, also take part in the work. ISO collaborates closely with the International Electrotechnical Commission (IEC) on all matters of electrotechnical standardization.

Draft International Standards adopted by the technical committees are circulated to the member bodies for voting. Publication as an International Standard requires approval by at least 75 % of the member bodies casting a vote.

International Standard ISO 9775 was prepared by Technical Committee ISO/TC 188, *Small craft*.

ISO 9775:1990

NOTE 1 This International Standard specifies requirements and test methods for remote steering systems as cited in clause 1. They are thus more specialized requirements than those given in a parallel document, ISO 8848, *Small craft — Remote steering systems*.

© ISO 1990

All rights reserved. No part of this publication may be reproduced or utilized in any form or by any means, electronic or mechanical, including photocopying and microfilm, without permission in writing from the publisher.

International Organization for Standardization
Case Postale 56 • CH-1211 Genève 20 • Switzerland

Printed in Switzerland

Small craft — Remote steering systems for single outboard motors of 15 kW to 40 kW power

1 Scope

This International Standard specifies requirements and test methods for remote push-pull cable steering systems and their major component items, used for small craft with a single outboard motor of 15 kW to 40 kW power.

2 Definitions

For the purposes of this International Standard, the following definitions apply.

2.1 steering system: Assembly including all components necessary to transmit remote manual effort to the outboard motor.

2.2 boat-mounted steering system: System in which an output ram guide tube is secured to the boat.

2.3 motor-mounted steering system: System in which an output ram guide tube is secured to the engine.

2.4 drag link: Device in a motor-mounted steering system by which the linear force of the output ram is transmitted to the motor steering arm.

2.5 helm: Mechanism, exclusive of a steering-wheel or other means for manual application of controlling force, by which controlling force is fed into a steering system cable or other force-transmission means.

2.6 minimum retained system performance: System capability after test(s) such that at least 90 % of the steering arc normally available each side of the mid-position may be obtained by exertion of no more than 27 N·m of torque at the helm, through the wheel or other normal control.

This criterion does not define steering system performance while a boat is underway but is intended to provide quantitative limits for design and test purposes.

3 General requirements

3.1 When steering systems are factory-installed in the boat, the complete system shall be supplied. In outboard motor-boats, the system shall be supplied complete to the interface point at the ram output end as shown in figure 1.

Dimensions in millimetres

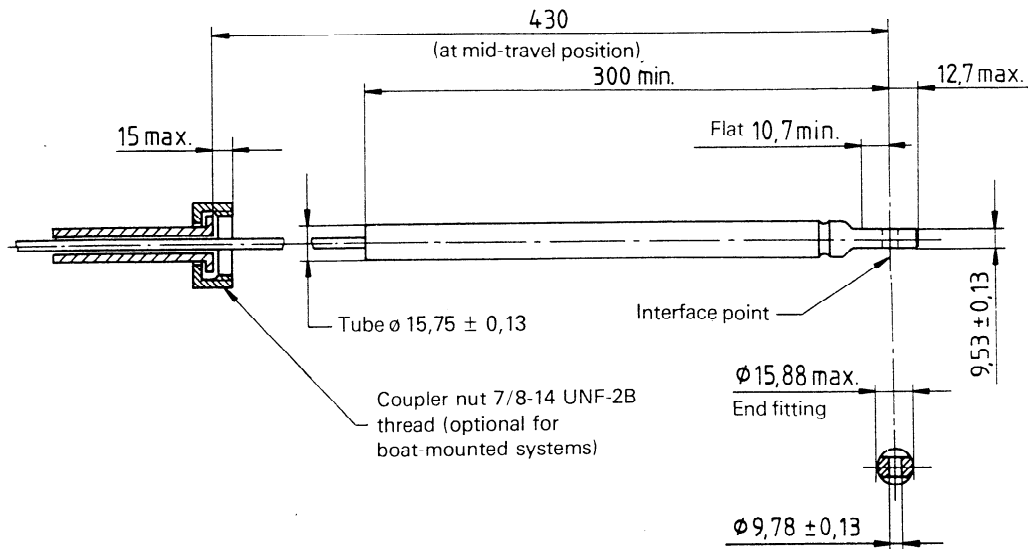

NOTE — Minimum travel: 100 mm each side of mid-travel position;
maximum travel: 115 mm each side of mid-travel position.

Figure 1 — Output ram
(standards.itech.ai)

3.2 The steering system selected shall be installed in accordance with this International Standard.

and complying with the requirements in 3.5.1 to 3.5.3.

3.3 It shall be specified whether the boat is suitable for motor-mounted steering systems, boat-mounted steering systems or both. If the boat is suitable for boat-mounted steering systems, it shall also be specified whether well mounting, transom mounting or both (see figure 2) may be used.

3.5.1 Loose lock-washers, fasteners with metallic distorting threads and adhesive are prohibited.

3.4 All threaded fasteners use of which affects safe operation of the steering system shall incorporate locking means.

3.5.2 Plain, threaded jam nuts are prohibited except that they may be used to permit adjustment and shall be designed so that total separation of parts or other complete loss of steering will not occur should they loosen.

3.5 Threaded fasteners use of which affects safe operation of the steering system and which are intended to be mounted or adjusted when installing the steering system in the boat, and which may be expected to be disturbed by installation or adjustment procedures, shall be locked by a locking device provided with instructions for correct assembly

NOTE 2 For assemblies not intended to be disassembled for installation, the choice of locking means is within the discretion of the system manufacturer.

3.5.3 A locking device shall be so designed that its presence can be determined by visual inspection or feel by a layman after installation.

3.6 Connection fittings including quick-disconnect fittings relying upon a spring or springs to maintain the connection shall not be used.

Dimensions in millimetres

NOTE — If the swivel is mounted in the motor well side fitting, the motor well shall provide for 380 mm mid-travel position from the swivel axis to the motor axis.

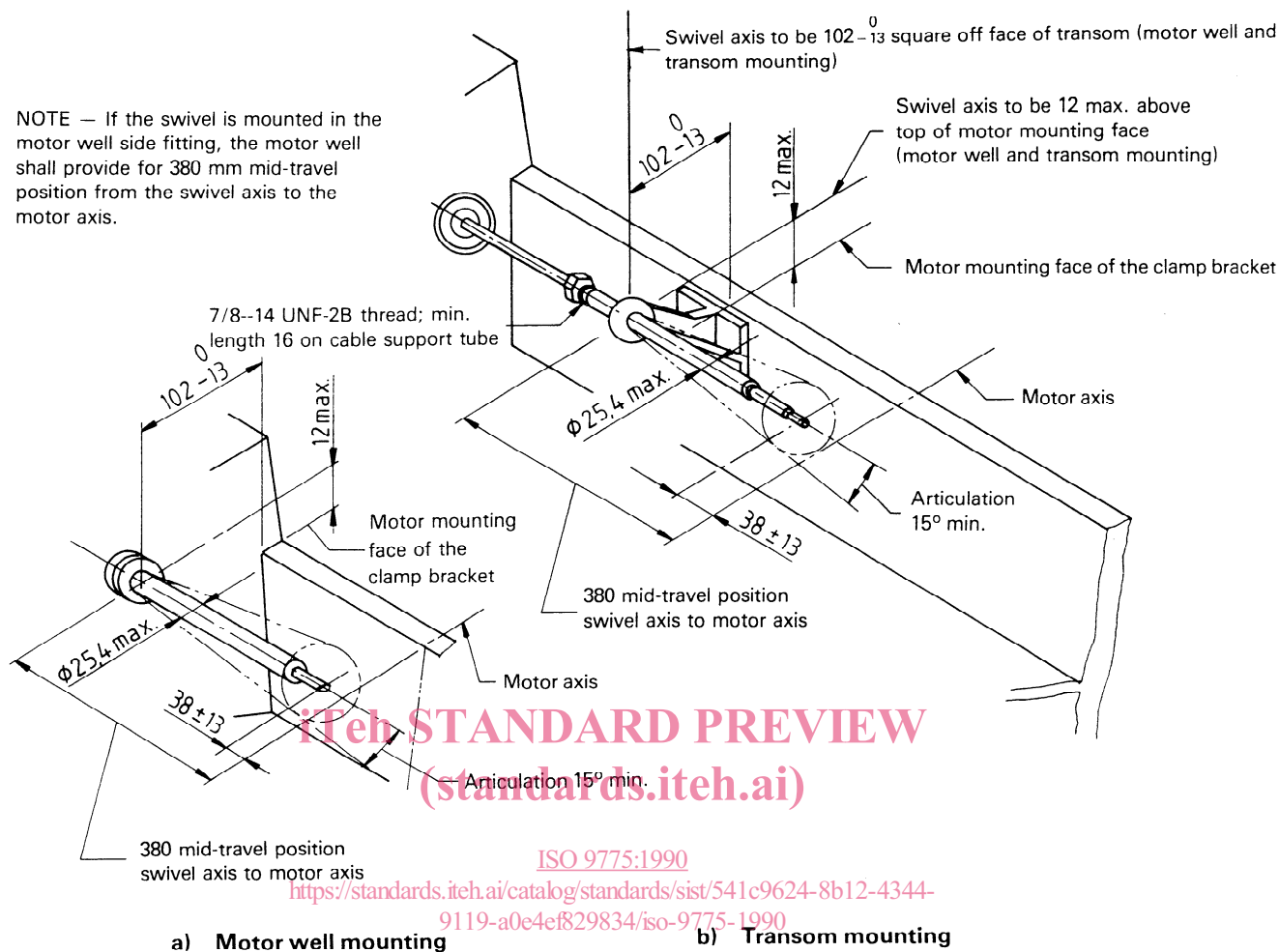

NOTE — Minimum travel : 100 mm each side of mid-travel position;
maximum travel : 115 mm each side of mid-travel position.

Figure 2 — Boat-mounted steering system

4 Outboard motor requirements

4.1 The steering stops on the outboard motor shall permit at least 30° of angular movement to either side.

4.2 Outboard motors shall meet the applicable dimensional requirements indicated in figure 3 and figure 4.

4.3 The necessary fittings to attach an outboard motor to the steering output ram shown in figure 1 shall be supplied with the outboard motor.

4.4 The outboard motor shall be designed so that, with any combination of motor turn and tilt, there shall be no damaging interference between the motor, its accessories, and both the boat-mounted system installed as shown in figure 2 and the

motor-mounted system, provided the motor is designed for both systems. Appropriate written information and installation instructions shall be provided, clearly indicating the type of steering system(s) that should be used.

4.5 Outboard motors shall be designed so that the geometry ensures that a static load of 2 200 N, applied at the steering-arm connection point normal to the steering arm in its normal plane of operation, throughout the maximum steering arc, will not result in steering output ram loadings greater than those specified in 7.2.1.

4.6 The steering arm of the outboard motor shall be provided with a 3/8-24 UNF thread, or a plain hole of 9,65 mm to 9,9 mm diameter at the connection point.

5 Steering system requirements

5.1 Motor-mounted steering systems shall meet the dimensional requirements indicated in figure 1, figure 3 and figure 4.

5.2 Boat-mounted steering systems for outboard motor installations shall meet the dimensional requirements indicated in figure 1 and figure 2. When a joint as shown in figure 2 is replaced by a universal joint with two movement axes, the axis perpendicular to the transom face shall be located 0 to 13 mm above the motor clamp bracket horizontal mounting face. The second axis shall be 100 mm to 115 mm from the inner surface of the transom and shall be not more than 28,5 mm from the first axis toward the motor.

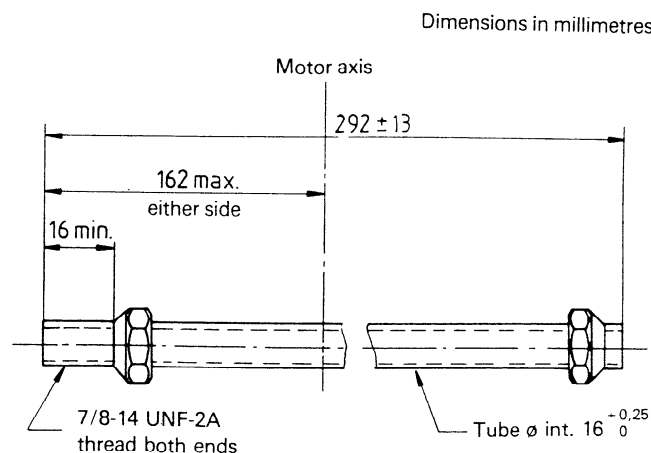

NOTE — The tube may be threaded equal length on both ends or reversible for port steering installations.

Figure 3 — Motor-mounted steering tube

iTech STANDARD PREVIEW
(standards.itech.ai)

ISO 9775:1990

<https://standards.itech.ai/catalog/standards/sist/541c9624-8b12-4344-9119-a0e4ef829834/iso-9775-1990>

5.3 Steering cables shall be marked at the engine end with a steering system length which shall be the length from the steering-wheel shaft centre to the hole centre in the steering output ram at the mid-travel position.

The steering cable shall also be marked by the manufacturer that the maximum power permissible is 40 kW.

5.4 Installation instructions for steering helms shall include recommendations for the maximum diameter and deepest wheel dish (see figure 5) that may be used with the helm. In addition, the maximum diameter and deepest wheel dish information shall be permanently marked on the helm assembly to be visible when the helm is installed with the wheel removed.

The helm assembly shall be permanently marked as above with the indication that the maximum permissible power is 40 kW.

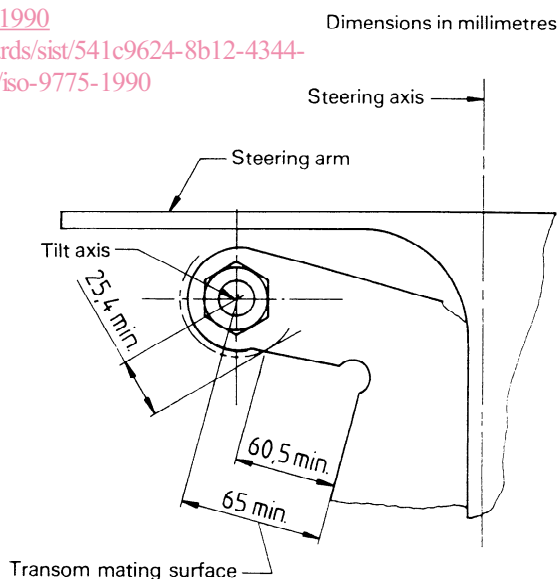
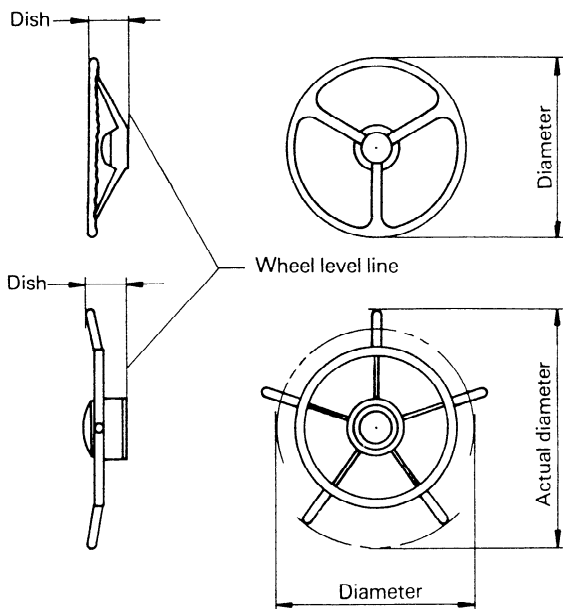

Figure 4 — Motor-mounted steering tilt axis



NOTE — The standard quoted diameter is taken as the actual diameter minus 50 mm.

Figure 5 — Steering-wheels

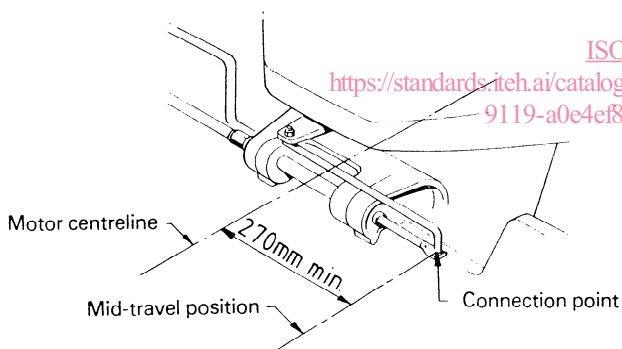

Figure 6 — Motor-mounted steering system

5.5 Steering systems and components shall be capable of meeting the applicable test requirements specified in clause 7.

5.6 Plastics and elastomers which may be exposed to sunlight shall be chosen to resist degradation by ultraviolet radiation.

5.7 Plastics and elastomers which may be installed in engine compartments shall be chosen to resist degradation by saline atmospheres, fuel, oil and heat.

6 Installation

6.1 Except for installations specifically intended for boats or outboard motors with special requirements, either the motor-mounted or the boat-mounted steering system shall be used.

6.2 If installing motor-mounted steering systems in outboard motor-boats, steering cables or other force-transmission means shall be selected so that, as installed and at mid-travel position, the output ram or equivalent component connection point shall reach at least 270 mm beyond the motor centreline as indicated in figure 6.

6.3 If installing boat-mounted steering systems in outboard motor-boats, steering cables or other force-transmission means shall be selected so that, as installed and at mid-travel position, the output ram or equivalent component connection point will reach at least to the motor centreline. The cable shall be attached to the boat to position the cable-anchor swivel with respect to the transom-motor centreline as specified in figure 2.

6.4 Cables shall be installed with as few bends as practicable. Bends should have as large a radius as practicable and the radius shall not be smaller than the manufacturer's recommended minimum.

6.5 Steering-wheels and helm shafts shall be selected to fit each other. Current fit configurations are shown in figure 7.

6.6 Steering systems and components as installed shall be capable of meeting the test requirements in 7.1.

6.7 If the steering cable passes through the side of an outboard motor well below the static float plane, the cable access port shall be appropriately sealed.

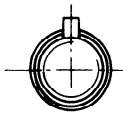

NOTE — Hub keyway: 4,79 mm min. and 5,07 mm max.

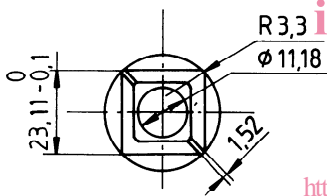
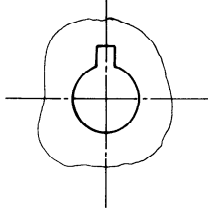
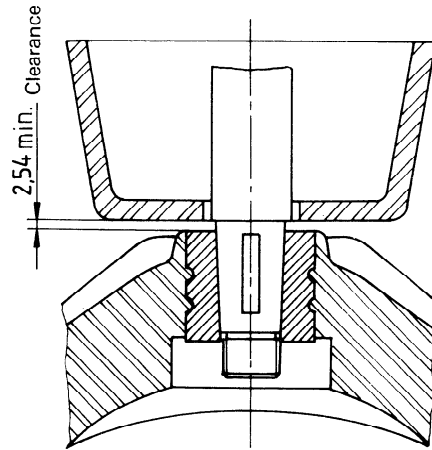
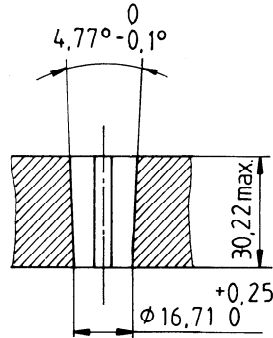
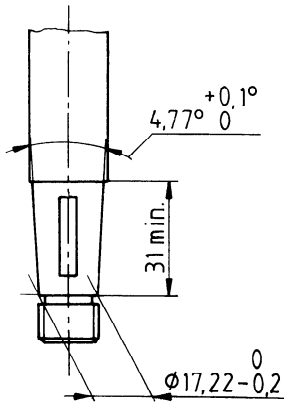

STANDARD PREVIEW
(standards.iteh.ai)

ISO 9775:1990

<https://standards.iteh.ai/catalog/standards/sist/541c9621-8b12-4344-9119-a0e4ef829834/iso-9775-1990>

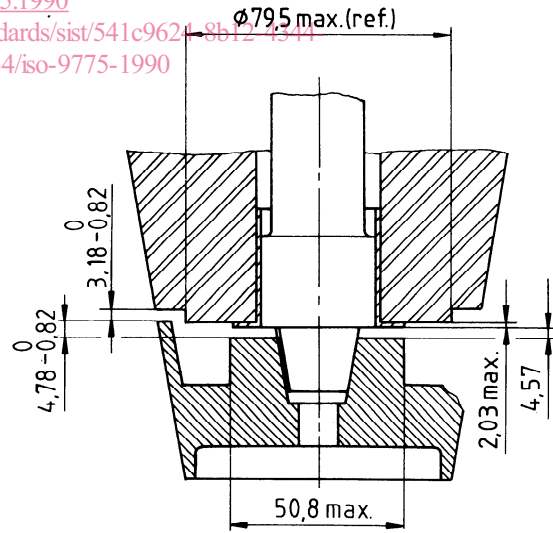
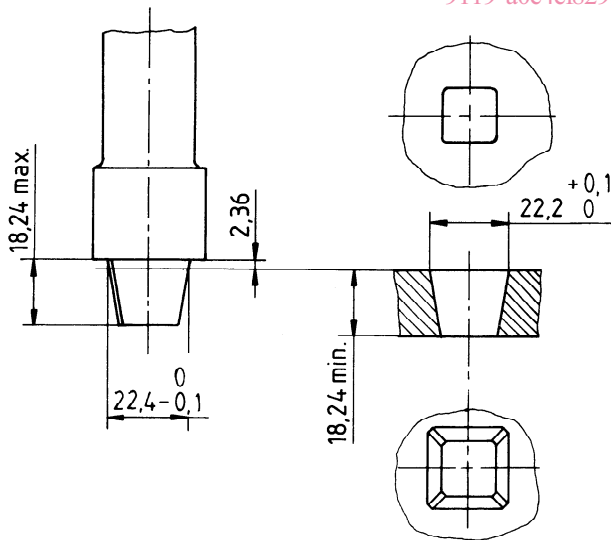

a) Clearance to shoulder

b) Hub

c) Steering shaft and wheel fit

Figure 7 — Steering shafts and steering-wheel hubs

7 Test requirements

7.1 As-installed tests

These tests are intended to establish the acceptability of the design strength of steering systems as installed in a boat to the interface with the outboard motor.

7.1.1 Steering systems shall withstand a static load in either direction of 2 200 N applied at the connection hole of the steering output ram along the axis of the steering output ram without deformation that, following the test, will cause any loss in steering capability or any dimensional change that results in non-compliance with figure 2. The permanent deformation shall not exceed 6,35 mm measured along the axis of the output ram.

7.1.2 Steering systems shall withstand a single tangential load in either direction of 450 N applied as appropriate:

- at any point on the steering-wheel rim,
- at the centre-point of any handgrip of an external spoke steering-wheel, or
- at the point of maximum leverage on other steering devices,

and a subsequent separate single axial load of 670 N, in each direction, distributed over not more than 100 mm of the rim, spoke or handgrip, at any location maintaining minimum retained system performance. Upon application of the indicated loads there shall be no fracture of the mounting surface or boat structure, nor deformation such that the required loads cannot be achieved.

A test for minimum retained system performance shall be performed on the steering system in its condition at the end of the load tests. Repairs to the system are not allowed prior to testing for minimum retained system performance. Failure to maintain minimum retained system performance or the separation of components necessary for steering control including separation of any portion of the helm, transom, or motor well mounts from the boat as a result of the application of the load forces specified in this clause all constitute failure.

7.2 Component tests

These tests are intended to establish minimum acceptable design criteria for components of steering systems.

7.2.1 Steering cable and output assembly tests

7.2.1.1 Each steering output and cable assembly (including boat-mounted system hardware) and each integral fitting shall withstand an axial load of 6 000 N in tension and compression, applied at the connection hole of the steering output ram throughout its travel range, without severance of components.

7.2.1.2 A separate cantilever load of 600 N shall be applied at the centreline of the hole in the steering output ram, with at least 190 mm of the ram unsupported, without more than 1,25 mm of permanent deflection at the ram hole.

7.2.1.3 The output ram of a push-pull steering cable shall withstand a cyclic load of $\pm 1\,100$ N applied as shown in figure 8, without causing separation of components. This load shall be applied for 50 000 reversals through the cable cross-hole.

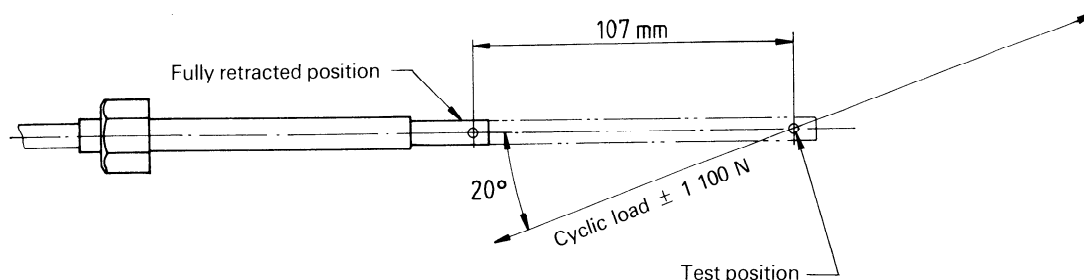

Figure 8 — Output ram fatigue test