



# SLOVENSKI STANDARD

## SIST EN 3757:2010

01-januar-2010

5 YfcbUj h\_U!`NU\_cj bY'a UhjWz̄gUa cnUdjfUbYz̄dfYa ] bYz̄gUa cj Ufcj UbYz̄  
Xj cglfUbg\_Yz̄]n`lcd`ctbccXdcfbY[ U`Y\_`Uza UnUbY'n`AcG&!`?'`Ug]z̄\_UY`U.`-\$`ADU  
ftdf]`hYa dYfUi fj`c\_c`jWz̄# %` `š7

Aerospace series - Nuts, anchor, self-locking, floating, self-aligning, two lug, in heat resisting steel, MoS2 lubricated - Classification: 900 MPa (at ambient temperature)/315 °C

iTeh STANDARD PREVIEW

Luft- und Raumfahrt - Anniemuttern, selbstsichernd, schwenkbar, beiderseitiger Flansch, aus hochwarmfestem Stahl, MoS2-geschmiert - Klasse: 900 MPa (bei Raumtemperatur)/315 °C

SIST EN 3757:2010

<https://standards.iteh.ai/catalog/standards/sist/e690e0bd-5425-4781-aff3-b382f1a2e310e210>

Série aérospatiale - Écrous à river, à freinage interne, flottants, orientables, double patte, acier résistant à chaud, lubrifiés MoS2 - Classification: 900 MPa (à température ambiante)/315 °C

Ta slovenski standard je istoveten z: EN 3757:2009

### ICS:

49.030.30 Matice Nuts

SIST EN 3757:2010 en

**iTeh STANDARD PREVIEW**  
**(standards.iteh.ai)**

SIST EN 3757:2010

<https://standards.iteh.ai/catalog/standards/sist/e690e0bd-5425-4781-aff3-eb4882b75ef6/sist-en-3757-2010>

EUROPEAN STANDARD

EN 3757

NORME EUROPÉENNE

EUROPÄISCHE NORM

November 2009

ICS 49.030.30

English Version

**Aerospace series - Nuts, anchor, self-locking, floating, self-aligning, two lugs, in heat resisting steel, MoS2 lubricated - Classification: 900 MPa (at ambient temperature) / 315 °C**

Série aérospatiale - Écrous à river, à freinage interne, flottants, orientables, double patte, acier résistant à chaud, lubrifiés MoS2 - Classification : 900 MPa (à température ambiante) / 315 °C

Luft- und Raumfahrt - Anniemuttern, selbstsichernd, schwenkbar, beiderseitiger Flansch, aus hochwarmfestem Stahl, MoS2-geschmiert - Klasse: 900 MPa (bei Raumtemperatur) / 315 °C

This European Standard was approved by CEN on 17 October 2009.

CEN members are bound to comply with the CEN/CENELEC Internal Regulations which stipulate the conditions for giving this European Standard the status of a national standard without any alteration. Up-to-date lists and bibliographical references concerning such national standards may be obtained on application to the CEN Management Centre or to any CEN member.

This European Standard exists in three official versions (English, French, German). A version in any other language made by translation under the responsibility of a CEN member into its own language and notified to the CEN Management Centre has the same status as the official versions.

CEN members are the national standards bodies of Austria, Belgium, Bulgaria, Cyprus, Czech Republic, Denmark, Estonia, Finland, France, Germany, Greece, Hungary, Iceland, Ireland, Italy, Latvia, Lithuania, Luxembourg, Malta, Netherlands, Norway, Poland, Portugal, Romania, Slovakia, Slovenia, Spain, Sweden, Switzerland and United Kingdom.



EUROPEAN COMMITTEE FOR STANDARDIZATION  
COMITÉ EUROPÉEN DE NORMALISATION  
EUROPÄISCHES KOMITEE FÜR NORMUNG

Management Centre: Avenue Marnix 17, B-1000 Brussels

**Contents**

Page

Foreword.....	3
1 Scope .....	4
2 Normative references .....	4
3 Required characteristics .....	5
4 Designation .....	7
5 Marking .....	7
6 Technical specification .....	7

**iTeh STANDARD PREVIEW**  
**(standards.iteh.ai)**

SIST EN 3757:2010

<https://standards.iteh.ai/catalog/standards/sist/e690e0bd-5425-4781-aff3-eb4882b75ef6/sist-en-3757-2010>

## Foreword

This document (EN 3757:2009) has been prepared by the Aerospace and Defence Industries Association of Europe - Standardization (ASD-STAN).

After enquiries and votes carried out in accordance with the rules of this Association, this Standard has received the approval of the National Associations and the Official Services of the member countries of ASD, prior to its presentation to CEN.

This European Standard shall be given the status of a national standard, either by publication of an identical text or by endorsement, at the latest by May 2010, and conflicting national standards shall be withdrawn at the latest by May 2010.

Attention is drawn to the possibility that some of the elements of this document may be the subject of patent rights. CEN [and/or CENELEC] shall not be held responsible for identifying any or all such patent rights.

According to the CEN/CENELEC Internal Regulations, the national standards organizations of the following countries are bound to implement this European Standard: Austria, Belgium, Bulgaria, Cyprus, Czech Republic, Denmark, Estonia, Finland, France, Germany, Greece, Hungary, Iceland, Ireland, Italy, Latvia, Lithuania, Luxembourg, Malta, Netherlands, Norway, Poland, Portugal, Romania, Slovakia, Slovenia, Spain, Sweden, Switzerland and the United Kingdom.

**ITEH STANDARD PREVIEW**  
**(standards.iteh.ai)**

[SIST EN 3757:2010](https://standards.iteh.ai/catalog/standards/sist/e690e0bd-5425-4781-aff3-eb4882b75ef6/sist-en-3757-2010)

[https://standards.iteh.ai/catalog/standards/sist/e690e0bd-5425-4781-aff3-  
eb4882b75ef6/sist-en-3757-2010](https://standards.iteh.ai/catalog/standards/sist/e690e0bd-5425-4781-aff3-eb4882b75ef6/sist-en-3757-2010)

**EN 3757:2009 (E)****1 Scope**

This European Standard specifies the characteristics of self-locking, floating, self-aligning, two lugs anchor nuts, in heat resisting steel, MoS<sub>2</sub>-lubricated.

Classification: 900 MPa <sup>1)</sup> / 315 °C <sup>2)</sup>.

**2 Normative references**

The following referenced documents are indispensable for the application of this document. For dated references, only the edition cited applies. For undated references, the latest edition of the referenced document (including any amendments) applies.

EN 2424:2008, *Aerospace series — Marking of aerospace products*

EN 2491, *Aerospace series — Molybdenum disulphide dry lubricants — Coating methods*

EN 9100, *Quality Management Systems — Requirements for Aviation, Space and Defense Organizations*

EN 9133, *Aerospace series — Quality management systems — Qualification procedure for aerospace standard parts*

ISO 5855-2, *Aerospace — MJ threads — Part 2: Limit dimensions for bolts and nuts*

ISO 5858, *Aerospace — Nuts, self-locking, with maximum operating temperature less than or equal to 425 °C — Procurement specification*

ISO 8788, *Aerospace — Nuts, metric — Tolerances of form and position*

ISO 12273, *Aerospace — Nuts, anchor, self-locking, floating, self-aligning, two lug, with MJ threads, classifications: 900 MPa (at ambient temperature)/235 °C, 900 MPa (at ambient temperature)/315 °C and 900 MPa (at ambient temperature)/425 °C — Dimensions*

TR 3791, *Aerospace series — Materials for self-locking nuts, threaded inserts and screw thread inserts of temperature classes ≤ 425 °C <sup>3)</sup>*

---

1) Corresponds to the minimum tensile stress which the nut is able to withstand at ambient temperature without breaking or cracking when tested with a bolt of a higher strength class.

2) Maximum temperature that the nut is able to withstand, without permanent alteration to its original characteristics, after ambient temperature has been restored. The maximum temperature is conditioned by the surface treatment.

3) Published as ASD-STAN Technical Report at the date of publication of this standard.

### 3 Required characteristics

#### 3.1 Configuration — Dimensions — Masses

See Figure 1 and Table 1.

Dimensions and tolerances are in conformity with ISO 12273, expressed in millimetres and apply before MoS<sub>2</sub> lubrication.

Details of form not stated are at the manufacturer's option.

#### 3.2 Tolerances of form and position

ISO 8788.

#### 3.3 Materials

TR 3791.

#### 3.4 Surface treatment

EN 2491, thickness not specified, mandatory on threads, optional on other surfaces.

6,3 / [ 3,2 / ]

These values in micrometres apply before surface treatment. They do not apply to threads punched holes or sheared edges, the surface texture of which will be as achieved by usual manufacturing methods.

Remove sharp edges 0.1 to 0.4.

[SIST EN 3757:2010](https://standards.itih.ai/catalog/standards/sist/e690e0bd-5425-4781-aff3-eb4882b75ef6/sist-en-3757-2010)

<https://standards.itih.ai/catalog/standards/sist/e690e0bd-5425-4781-aff3-eb4882b75ef6/sist-en-3757-2010>

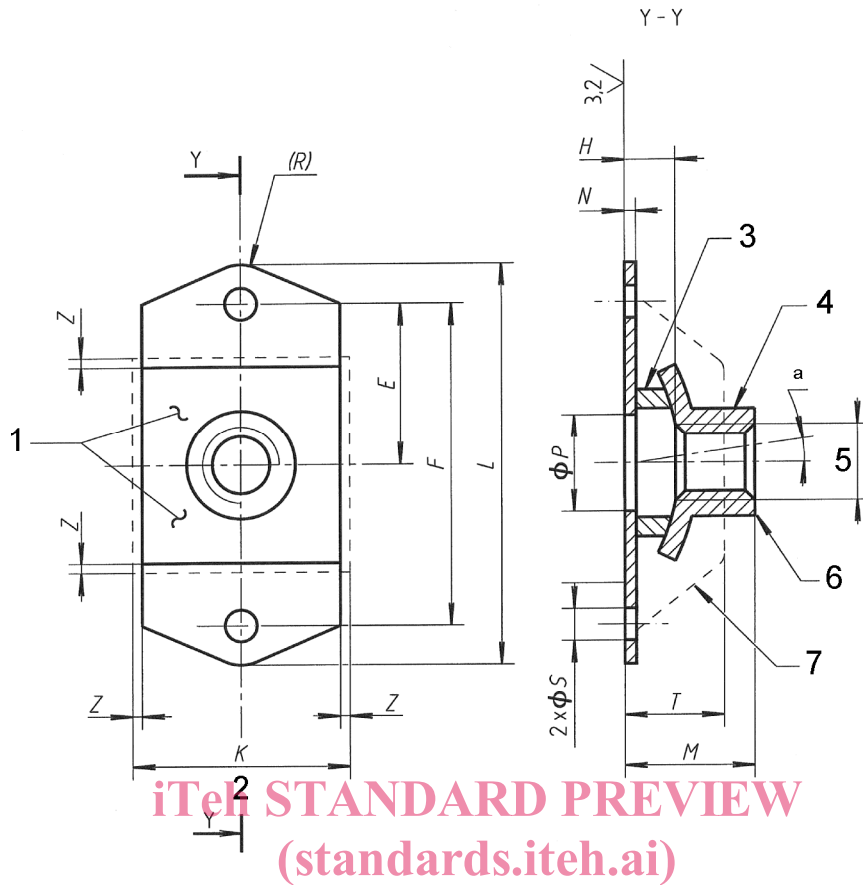
**Key**

- 1 Marking
- 2 Float inclusive
- 3 Convex washer
- 4 Threaded element
- 5 Thread
- 6 Form out-of-round in this area to achieve the self-locking torque requirements. Tooling marks are permitted in this area.
- 7 Cage
- a 8° minimum alignment in any direction from central position

**Figure 1**