

INTERNATIONAL STANDARD

ISO
9787

First edition
1990-12-01

Manipulating industrial robots — Coordinate systems and motions

iTeh STANDARD PREVIEW
*Robots manipulateurs industriels — Systèmes de coordonnées et
mouvements*
(standards.iteh.ai)

ISO 9787:1990

<https://standards.iteh.ai/catalog/standards/sist/eb60f8cc-2c28-4446-b5aa-8c099f64b033/iso-9787-1990>



Reference number
ISO 9787:1990(E)

Foreword

ISO (the International Organization for Standardization) is a worldwide federation of national standards bodies (ISO member bodies). The work of preparing International Standards is normally carried out through ISO technical committees. Each member body interested in a subject for which a technical committee has been established has the right to be represented on that committee. International organizations, governmental and non-governmental, in liaison with ISO, also take part in the work. ISO collaborates closely with the International Electrotechnical Commission (IEC) on all matters of electrotechnical standardization.

Draft International Standards adopted by the technical committees are circulated to the member bodies for voting. Publication as an International Standard requires approval by at least 75 % of the member bodies casting a vote.

International Standard ISO 9787 was prepared by Technical Committee ISO/TC 184, *Industrial automation systems and integration*.

Annex A of this International Standard is for information only.

[ISO 9787:1990](https://standards.iteh.ai/catalog/standards/sist/eb60f8cc-2c28-4446-b5aa-8c099f64b033/iso-9787-1990)

<https://standards.iteh.ai/catalog/standards/sist/eb60f8cc-2c28-4446-b5aa-8c099f64b033/iso-9787-1990>

© ISO 1990

All rights reserved. No part of this publication may be reproduced or utilized in any form or by any means, electronic or mechanical, including photocopying and microfilm, without permission in writing from the publisher.

International Organization for Standardization
Case Postale 56 • CH-1211 Genève 20 • Switzerland

Printed in Switzerland

Introduction

ISO 9787 is one of a series of International Standards dealing with the manipulating industrial robots. Other documents cover such topics as safety, general characteristics, performance criteria and related testing methods, terminology, and mechanical interfaces. It is noted that these standards are interrelated and are also related to other International Standards.

iTeh STANDARD PREVIEW
(standards.iteh.ai)

[ISO 9787:1990](https://standards.iteh.ai/catalog/standards/sist/eb60f8cc-2c28-4446-b5aa-8c099f64b033/iso-9787-1990)

<https://standards.iteh.ai/catalog/standards/sist/eb60f8cc-2c28-4446-b5aa-8c099f64b033/iso-9787-1990>

Manipulating industrial robots — Coordinate systems and motions

1 Scope

This International Standard defines and specifies three robot coordinate systems; it also gives the axis nomenclature. It is intended to aid in robot alignment, testing, and programming.

This International Standard applies to all manipulating industrial robots as defined in ISO/TR 8373.

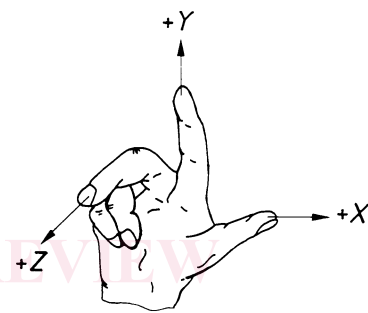

Figure 1 — Right-hand coordinate system

2 Normative reference

The following standard contains provisions which, through reference in this text, constitute provisions of this International Standard. At the time of publication, the edition indicated was valid. All standards are subject to revision, and parties to agreements based on this International Standard are encouraged to investigate the possibility of applying the most recent edition of the standard indicated below. Members of IEC and ISO maintain registers of currently valid International Standards.

ISO/TR 8373:1988, *Manipulating industrial robots — Vocabulary*.

3 Definitions

For the purposes of this International Standard, the definitions given in ISO/TR 8373 apply.

4 Defined coordinate systems

All coordinate systems described in this International Standard are defined by the right-hand rule as shown in figure 1.

A , B and C define rotary motions about axes respectively parallel to X , Y and Z .

Positive A , B and C are in the directions to advance right-hand screws in the positive X , Y and Z directions respectively (see figure 2).

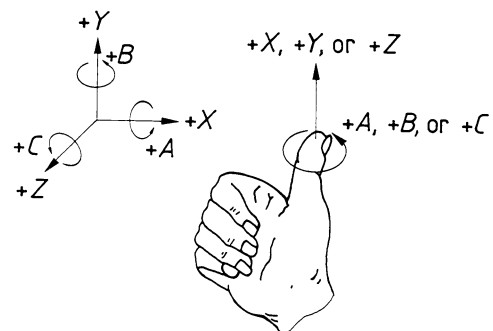

Figure 2 — Rotary motions

The three coordinate systems described are the World, Base, and Mechanical Interface, each referring to the plane in which the X - Y axes lie (e.g. the X - Y axes of the base coordinate system lie in the plane of the base mounting surface). The Z axis is

perpendicular to the X - Y plane. Figure 3 shows an example of the three coordinate systems described in this International Standard.

Although this International Standard defines only three coordinate systems, others may be defined.

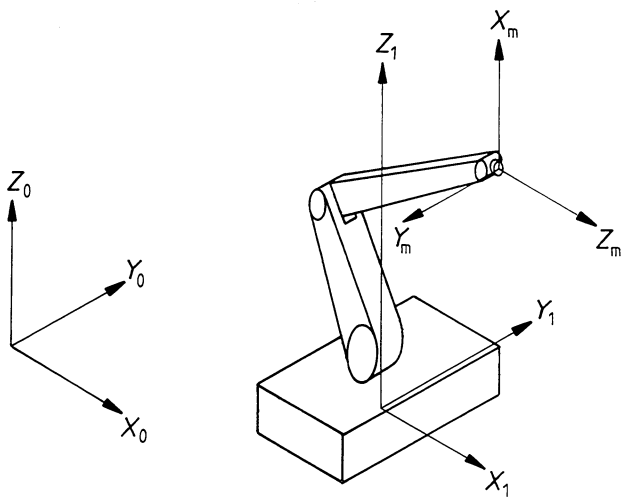

Figure 3 — Coordinate systems

5 World coordinate system

5.1 Notation

$X_0 - Y_0 - Z_0$

5.2 Origin

The origin of the world coordinate system is to be defined by the users according to their requirements.

5.3 $+Z_0$ axis

The $+Z_0$ axis is colinear but in the opposite direction to the acceleration of gravity vector.

5.4 $+X_0$ axis

The $+X_0$ axis is to be defined by the users according to their requirements.

6 Base coordinate system

6.1 Notation

$X_1 - Y_1 - Z_1$

6.2 Origin

The origin shall be defined by the manufacturer of the robot.

6.3 $+Z_1$ axis

The $+Z_1$ axis is in the direction of the mechanical structure of the robot pointing away from the base mounting surface.

6.4 $+X_1$ axis

The $+X_1$ axis points away from the origin and passes through the projection of the centre point of the robot working space, C_w , on to the plane of the base mounting surface (see figure 4). When the robot configuration precludes this convention, the direction of the $+X_1$ axis shall be defined by the manufacturer.

NOTE 1 Examples of the application of the base and mechanical interface coordinate systems are found in annex A.

STANDARD PREVIEW
(standards.iteh.ai)

ISO 9787:1990

<https://standards.iteh.ai/catalog/standards/sist/eb60f8cc-2c28-4446-b57a-8e099f67b033/iso-9787-1990>

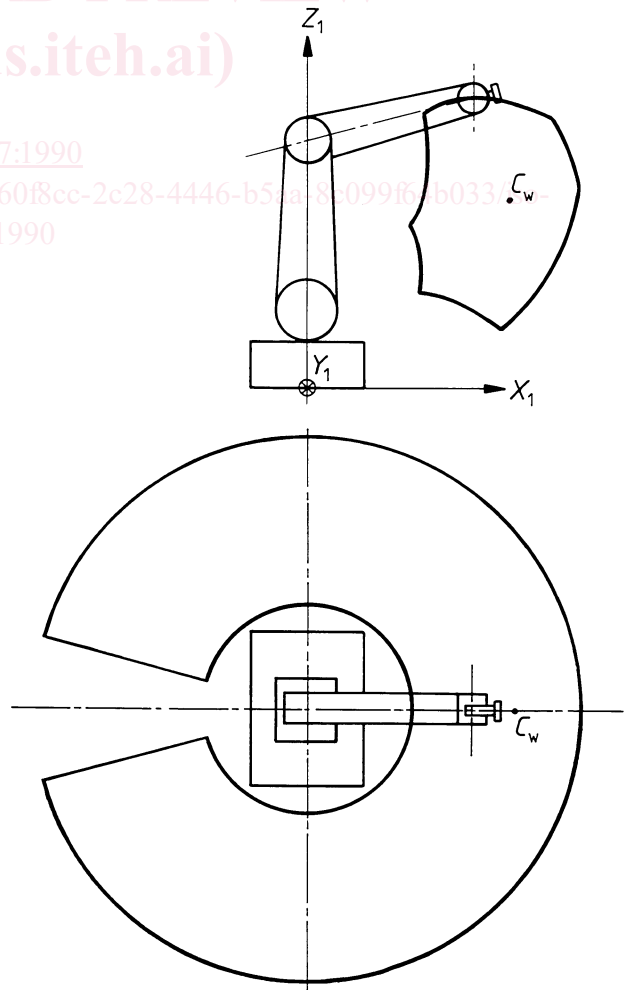

Figure 4 — Example of robot working space

7 Mechanical interface coordinate system

7.1 Notation

$X_m - Y_m - Z_m$ ($m =$ number of robot axes (n) + 1)

7.2 Origin

The origin is the centre of the mechanical interface.

7.3 $+Z_m$ axis

The $+Z_m$ axis points away from the mechanical interface toward the end effector.

7.4 $+X_m$ axis

The $+X_m$ axis is defined by the intersection of the plane of the mechanical interface and the plane $X_1 Z_1$ (or a plane parallel to $X_1 Z_1$) such that the origin of the mechanical interface coordinate system lies on the line of intersection, with the robot primary and secondary axes in their mid-positions. When the robot configuration precludes this convention, the position of the primary axes shall be defined by the manufacturer. The $+X_m$ axis points away from the Z_1 axis. In the case where Z_1 and X_m are parallel, the $+X_m$ axis is in the same direction as the $+Z_1$ axis.

NOTE 2 Examples of the application of the base and mechanical interface coordinate systems are found in annex A.

8 Robot motions

8.1 Linear motions

When linear motions of the end effector are defined in the base coordinate system, they are designated by the following directions:

+ or $-x$ along or parallel to the X_1 axis;

+ or $-y$ along or parallel to the Y_1 axis;

+ or $-z$ along or parallel to the Z_1 axis.

8.2 Rotary motions

Under consideration.

9 Robot axis nomenclature

If the axes are numerically designated, axis 1 shall be the first motion closest to the base mounting surface, axis 2 the second motion, and so on, and axis n the motion to which the mechanical interface is attached.

NOTE 3 Examples of robot axis nomenclature are found in annex A.

Annex A
(informative)

Examples of application for different mechanical structures

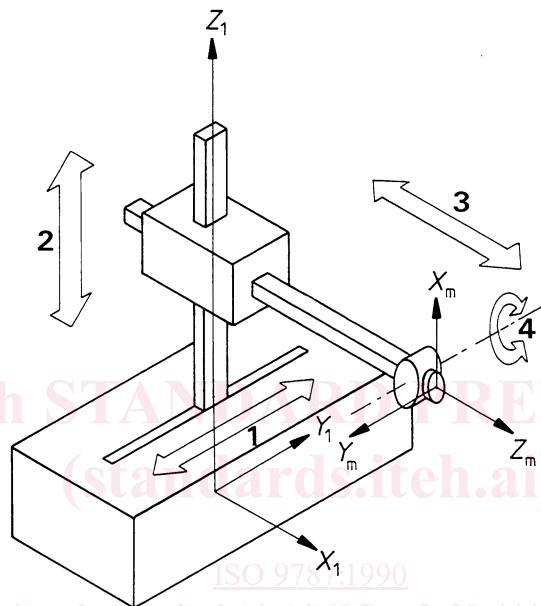

Figure A.1 — Rectangular robot

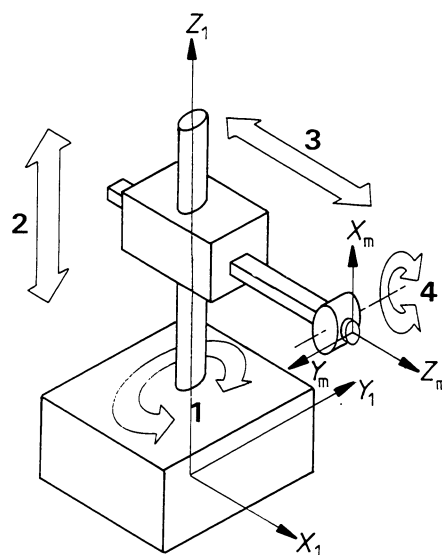

Figure A.2 — Cylindrical robot

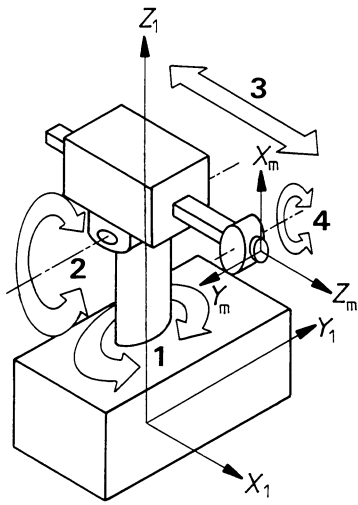

Figure A.3 — Polar robot

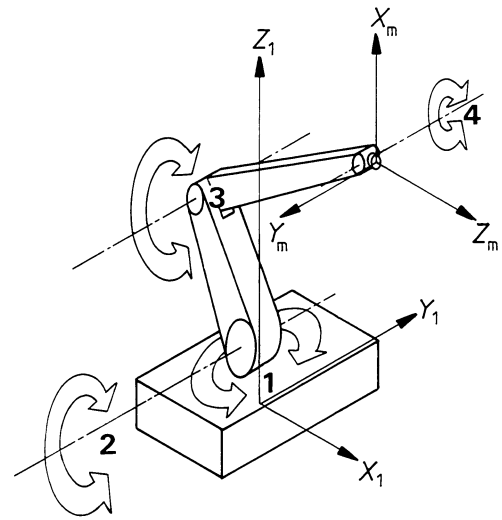

Figure A.4 — Revolute robot

iTeh STANDARD PREVIEW
(standards.iteh.ai)

ISO 9787:1990
<https://standards.iteh.ai/catalog/standards/iso/9787-1990>

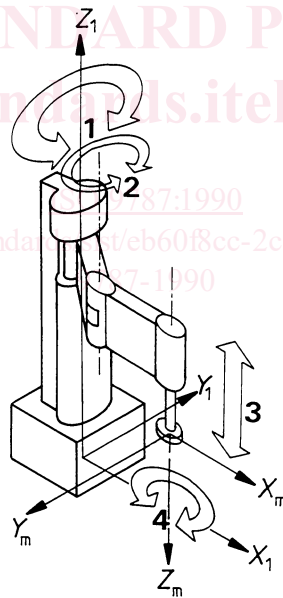

Figure A.5 — Polar robot

