



Designation: C 110 – 02

Standard Test Methods for Physical Testing of Quicklime, Hydrated Lime, and Limestone¹

This standard is issued under the fixed designation C 110; the number immediately following the designation indicates the year of original adoption or, in the case of revision, the year of last revision. A number in parentheses indicates the year of last reapproval. A superscript epsilon (ϵ) indicates an editorial change since the last revision or reapproval.

This standard has been approved for use by agencies of the Department of Defense.

1. Scope

1.1 These test methods cover physical testing of quicklime and hydrated lime, and of limestone not otherwise covered in ASTM standards.²

NOTE 1—Quicklime and hydrated lime have a high affinity for moisture and carbon dioxide. Caution should be taken to protect both hydrated and quicklime during sampling, storage, and testing (see Practice C 50).

1.2 The test procedures appear in the following order:

	Section
Air Entrainment	13
Apparent Loose Density of Hydrated Lime, Pulverized Quicklime, and Limestone	16
Apparent Packed Density of Hydrated Lime, Pulverized Quicklime, and Limestone	17
Autoclave Expansion of Hydrated Lime	8
Dry Brightness of Pulverized Limestone	15
Dry Screening by Air Jet Sieve	19
Fineness of Pulverized Quicklime and Hydrated Lime by Air Permeability	18
Limestone Grindability	20
Particle Size of Pulverized Limestone	14
Plasticity of Lime Putty	7
Popping and Pitting of Hydrated Lime	9
Residue and Sieve Analysis	5
Settling Rate of Hydrated Lime	11
Slaking Rate of Quicklime	12
Specific Gravity of Hydrated Lime Products	21
Standard Consistency of Lime Putty	6
Water Retention of Hydrated Lime	10
Wet Sieve Analysis of Agricultural Liming Materials	22

1.3 The values stated in SI units are to be regarded as the standard.

1.4 *This standard does not purport to address all of the safety concerns, if any, associated with its use. It is the responsibility of the user of this standard to establish appropriate safety and health practices and determine the applicability of regulatory limitations prior to use.*

2. Referenced Documents

2.1 ASTM Standards:

- C 25 Test Methods for Chemical Analysis of Limestone, Quicklime, and Hydrated Lime³
- C 28 Specification for Gypsum Plasters³
- C 50 Practice for Sampling, Inspection, Packing, and Marking of Lime and Limestone Products³
- C 51 Terminology Relating to Lime and Limestone (as used by the Industry)³
- C 91 Specification for Masonry Cement³
- C 109 Test Method for Compressive Strength of Hydraulic Cement Mortars (Using 2-in. or 50-mm Cube Specimens)³
- C 117 Test Method for Material Finer than 75-Micrometre (No. 200) Sieve in Mineral Aggregates by Washing⁴
- C 136 Test Method for Sieve Analysis of Fine and Coarse Aggregates⁴
- C 150 Specification for Portland Cement³
- C 185 Test Method for Air Content of Hydraulic Cement Mortar³
- C 188 Test Method for Density of Hydraulic Cement³
- C 204 Test Method for Fineness of Hydraulic Cement by Air Permeability Apparatus³
- C 207 Specification for Hydrated Lime for Masonry Purposes³
- C 230 Specification for Flow Table for Use in Tests of Hydraulic Cement³
- C 305 Practice for Mechanical Mixing of Hydraulic Cement Pastes and Mortars of Plastic Consistency³
- C 430 Test Method for Fineness of Hydraulic Cement by the 45- μ m (No. 325) Sieve³
- C 472 Test Methods for Physical Testing of Gypsum, Gypsum Plasters and Gypsum Concrete³
- C 670 Practice for Preparing Precision and Bias Statements for Test Methods for Construction Materials⁴
- C 702 Practice for Reducing Field Samples of Aggregate to Testing Size⁴
- C 778 Specification for Standard Sand³
- C 1005 Specification for Weights and Weighing Devices for Use in the Physical Testing of Hydraulic Cements³

¹ These test methods are under the jurisdiction of ASTM Committee C07 on Lime and are the direct responsibility of Subcommittee C07.06 on Physical Tests.

Current edition approved June 10, 2002. Published August 2002. Originally published as C 110 – 34 T. Last previous edition C 110 – 00a.

² For tests on limestone as aggregate, see Vol 04.02 of the *Annual Book of ASTM Standards*. For tests on limestone as building stone, see Vol 04.05 of the *Annual Book of ASTM Standards*.

³ *Annual Book of ASTM Standards*, Vol 04.01.

⁴ *Annual Book of ASTM Standards*, Vol 04.02.

- D 75 Practice for Sampling Aggregates⁵
- E 11 Specification for Wire and Cloth Sieves for Testing Purposes⁶
- E 29 Practice for Using Significant Digits in Test Data to Determine Conformance with Specifications⁶
- E 691 Practice for Conducting an Interlaboratory Study to Determine the Precision of a Test Method⁶

3. Terminology

3.1 *Definitions*—Unless otherwise specified, for definitions of terms used in this standard see Terminology C 51.

4. General Procedures

4.1 *Sampling*—Samples of lime and limestone for chemical analysis shall be taken and prepared in accordance with the requirements of Practice C 50 applicable to the material to be tested.

4.2 Calculation:

4.2.1 The calculations included in the individual procedures sometimes assume that the exact weight specified has been used. Accurately weighed samples which are approximately but not exactly equal to the weight specified may be used provided appropriate corrections are made in the calculation. Unless otherwise stated, weights of all samples and residues should be recorded to the nearest 0.0001 g.

4.2.2 In all mathematical operations on a set of observed values, the equivalent of two more places of figures than in the single observed values shall be retained. For example, if observed values are read or determined to the nearest 0.1 mg, carry numbers to the nearest 0.001 mg in calculation.

4.3 *Rounding Figures*—Rounding of figures to the nearest significant place required in the report should be done after the calculations are completed, in order to keep the final results free from calculation errors. The rounding procedure should follow the principle outlined in Practice E 29.

5. Residue and Sieve Analysis

5.1 Significance and Use:

5.1.1 This test method determines the residue obtained from slaking quicklime. Residue, in this case, is largely unreacted material such as uncalcined limestone or dolomite, overburned quicklime, or gross impurities, or a combination of these.

5.2 Apparatus:

5.2.1 The sieves used shall conform to the requirements of Specification E 11. Preferably the sieves should have a 4-in. depth.

5.2.2 If sieve calibrations are required, follow the method as outlined in Test Method C 430.

5.2.3 *Spray Nozzle* conforming to the requirements of Test Method C 430.⁷

5.2.4 *Pressure Gage* shall be 3-in. (75-mm) minimum diameter, and shall be graduated in 1-psi (6.9 kPa) increments, and shall have a maximum capacity of 30-psi (207 kPa). The accuracy at 10 psi (69 kPa) shall be ± 0.25 psi (± 1.7 kPa).⁷

5.2.5 Attach a pressure gage to the water faucet and a rubber tubing to the output side of the pressure gage. On the other end of the rubber tubing attach the spray nozzle (see 5.2.3).

5.3 Residue of Quicklime:

5.3.1 Select a representative 2.5-kg (5-lb) sample of the quicklime. Break lime selected for this test so as to entirely pass a 25.0-mm (1-in.) square mesh screen. Test the pulverized lime as received. Place the sample in a box of wood or of some material of similarly low thermal conductivity, and an experienced operator should slake it with sufficient water at 21 to 27°C (70 to 80°F) to produce the maximum quantity of lime putty, carefully avoiding “burning” or “drowning” the lime. Allow it to stand for 1 h and then wash through an 850- μ m (No. 20) sieve by a stream of water having a moderate pressure. Do not rub any material through the sieve. Continue the washing until the residue on the screen appears to consist entirely of coarse particles, but in no case continue the washing for more than 30 min. Dry the residue to constant weight at a temperature of 100 to 107°C (212 to 225°F) and calculate the percentage residue, based on the original weight of the sample.

5.4 Sieve Analysis of Hydrated Lime:

5.4.1 Select a 100-g sample of the hydrated lime as received and place on a 600- μ m (No. 30) sieve, which is nested above a 75- μ m (No. 200) sieve. Wash the material through the sieves by means of a stream of water from the nozzle attached to a rubber tubing (see 5.2.5) after adjusting the water pressure to 10 psi (69 kPa) ± 0.25 psi (± 1.7 kPa). Carefully wash the sample through the sieves without allowing any splashing over the sides of the sieve. After the sample is washed through the top sieve, separate the two sieves and continue washing through the 75- μ m (No. 200) sieve until the water coming through the sieve is clear, that is, no particles can be seen in a beaker of the rinse water, but in no case continue the washing longer than 30 min. Take care not to let water accumulate on the 75- μ m (No. 200) sieve, because the openings will become clogged and the operation cannot be completed in 30 min.

5.4.2 Calculate the percentage residue retained on each sieve, based on the original weight of the sample. The weight of the material retained on the 600- μ m (No. 30) sieve shall be added to the weight of the material retained on the 75- μ m sieve to obtain the correct weight of the material retained on the 75- μ m sieve.

5.5 Sieve Analysis of Limestone and Dry Quicklime:

5.5.1 Select the desired sieves and nest them with the coarsest sieves on top. Weigh a 100-g sample of the material to be tested and place it on the top sieve. Conduct the sieving operation by means of a lateral and vertical motion of the sieve accompanied by a jarring action to keep the sample moving continuously over the surface of the sieve. Continue sieving until not more than 1 % of the residue passes any sieve during 1 min. If mechanical sieving is used, the device shall be such as to impart the type of agitation described in the hand sieving operation. Continue the shaking for a period of 15 min.

5.5.2 Weigh the residue retained on each sieve to the nearest 0.1 g. Report the results of the sieve analysis as follows: (1) total percentages passing each sieve, (2) total percentages retained on each sieve, or (3) percentages retained between

⁵ Annual Book of ASTM Standards, Vol 04.03.

⁶ Annual Book of ASTM Standards, Vol 14.02.

⁷ A wet washing spray attachment, Soiltest Model CL-364, or equivalent has been found suitable for this purpose. Available from Soiltest, Inc., 86 Albrecht Drive, P.O. Box 8004, Lake Bluff, IL 60044-8004.

consecutive sieves, depending upon the form of the specification for the use of the material under test.

5.6 Precision and Bias:

5.6.1 No precision data are available due to the limited use of these test methods. Therefore, users are advised to develop their own laboratory precision. No statement is being made about the bias of these test methods.

6. Standard Consistency of Lime Putty

6.1 Significance and Use:

6.1.1 In order to measure certain physical properties of a lime putty, such as plasticity, it is necessary to have a uniform or standard consistency (viscosity), since the property measurement is affected by the consistency level.

6.2 Apparatus:

6.2.1 *Modified Vicat Apparatus*—The apparatus, constructed as shown in Fig. 1, shall consist of a bracket, *A*, bearing a movable brass rod, *B*, 6.3 mm in diameter and of suitable length to fit the Vicat bracket. A plunger, *C*, 12.5 mm in diameter, made of aluminum tubing, shall be attached to the lower end of the rod. The total weight of the rod with plunger shall be 30 g. The lower end of the plunger shall be closed without shoulders or curvature and the tube may be loaded with shot to the specified weight. The total weight required may also be obtained by means of a weight, *D*, screwed into the rod. The rod can be held in any position by means of a screw, *E*, and has a mark midway between the ends which moves under a scale, *F*, graduated in millimetres, attached to the bracket, *A*.

6.2.2 *Mold*—The conical ring mold shall be made of a noncorroding, nonabsorbent material, and shall have an inside diameter of 70 mm at the base and 60 mm at the top, and a height of 40 mm.

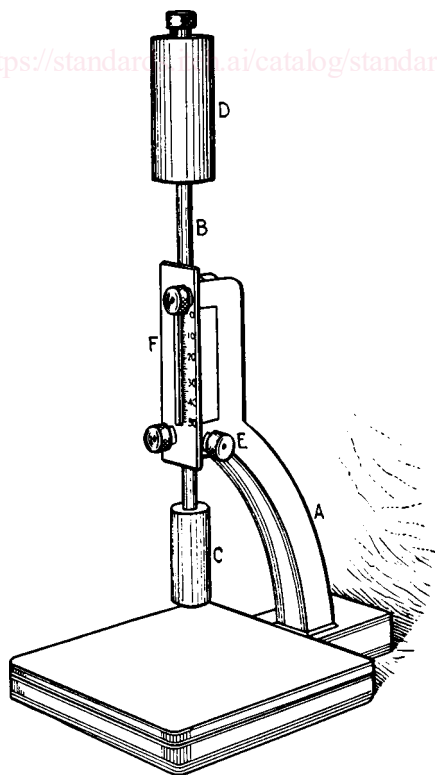

FIG. 1 Modified Vicat Apparatus

6.2.3 *Base Plate*—The base plate for supporting the ring mold shall be of plate glass and about 100 mm square.

6.2.4 Mechanical Mixers⁸

6.3 Standard Consistency Determination:

6.3.1 *Mechanical Mixing Procedure Using the Vac-U-Mixer*—To a measured amount of water contained in an 800-cm³ Vac-U-Mix bowl, add 300 g of hydrated lime and hand mix for 10 s with a stiff spatula (Note 2). Cover putty to prevent evaporation of water. After the applicable soaking period, 30 min maximum for Type S, special hydrated lime, and not less than 16 h nor more than 24 h for Type N, normal hydrated lime, insert the paddle assembly and mix the putty for 30 s with the mechanical mixer. Remove the paddle assembly and scrape down any putty adhering to it and to the sides of the mixing bowl. Remix for 30 s and determine the consistency as prescribed in 6.3. If the penetration is less than 15 mm, return all of the material to the mixer bowl, add additional water, and remix for 15 s. If the penetration is greater than 25 mm, repeat the test.

NOTE 2—Most lime hydrates will require 250 to 300 mL of water to produce a putty of proper consistency for this test if 300 g of lime are used.

6.3.2 *Mechanical Mixing Procedure Using the Hobart N-50 Mixer*—To a measured amount of water contained in the N-50 mixing bowl, add 600 g of hydrated lime and hand mix for 10 s with a stiff spatula (Note 3). Cover putty to prevent evaporation of water. After the applicable soaking period, 30 min maximum for Type S, special hydrated lime, and not less than 16 h nor more than 24 h for Type N, normal hydrated lime, insert the paddle assembly and mix the putty for 1 min at a slow speed. Stop the mixer and scrape down the paddle and the sides of the mixing bowl. Remix for 4 min at a slow speed. Determine the consistency as prescribed in 6.3.3. If the penetration is less than 15 mm, return all of the material to the mixing bowl, add additional water, and remix for 15 s. If the penetration is more than 25 mm, repeat the test.

NOTE 3—Most lime hydrates will require 500 to 600 mL of water to produce a putty of proper consistency for this test if 600 g of lime are used.

6.3.3 *Consistency Determination*—To determine consistency, place the mold with its larger end resting on the glass base plate and fill with the lime putty. Then strike off the putty flush with the top of the mold. Center the lime putty, confined in the ring mold resting on the plate, under the rod of the modified Vicat apparatus (Fig. 1). Bring the plunger end, *C*, in contact with the surface of the lime putty and take an initial reading. Release the rod and take the final reading 30 s after the plunger is released. The lime putty is of standard consistency when a penetration of 20 ± 5 mm is obtained. Record both the total amount of water required to bring the putty to standard consistency and the actual penetration. Proceed with the plasticity determination in accordance with 7.3.

6.4 Precision and Bias:

6.4.1 The precision and bias of this test method has not been determined.

⁸ A Vac-U-Mixer or an N-50 Hobart Mixer, or equivalent, has been found suitable for this purpose.

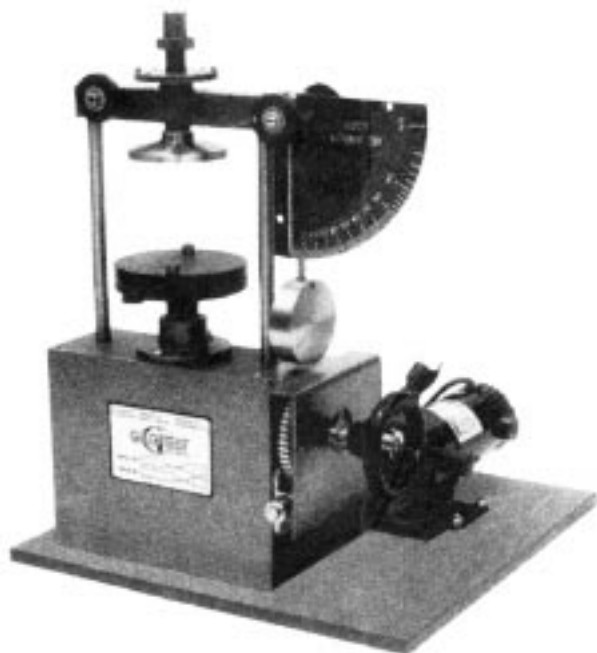

Constants of the Machine:

Absorption of Porcelain Base Plate—minimum of 40 g in 24 h. For rate of absorption of base plates see 7.2.3.2.

Dimension of Base Plate—25 mm (1 in.) in thickness by 100 mm (4 in.) in diameter.

Dimensions of Disk—0.8 mm (1/32 in.) in thickness by 76 mm (3 in.) in diameter.

Speed of Vertical Shaft—1 revolution in 6 min, 40 s.

Torque on Disk when Bob Reading is 100—1.41 N·m.

FIG. 2 Emley Plasticimeter

7. Plasticity of Lime Putty

7.1 Significance and Use:

7.1.1 This test method provides a measure of the degree of stiffening of lime putty of standard consistency as water is withdrawn from it by a standard suction base plate.

7.1.2 Plasticity is an important property when applying mixtures containing lime putty to porous or absorptive surfaces such as in plastering, stuccoing, and masonry construction.

7.2 Apparatus:

7.2.1 Determine the plasticity of lime putty using the plasticimeter shown in Fig. 2.⁹

7.2.2 *Cleaning and Care of Base Plates*— In making the plasticity determinations, much of the success attainable depends upon the condition of the base plates. In the case of porcelain plates which are reused, improper cleaning results in clogging of the pores with reduction in the rate of absorption. After a plate has been used, wipe the excess lime off and immerse the plate in clear water for not less than 2 h, after which transfer it without drying to a dilute solution of hydrochloric acid (HCl, 1 + 9) where it shall be kept immersed

for another 2 h. Then transfer to a receptacle containing running water for at least 1 h. The plate is then free of acid. After the removal of excess water, place the plate in an oven overnight at a temperature of between 100 and 110°C (212 and 230°F) for drying. Before using, cool the plate to room temperature.

7.2.3 Absorption of Plasticimeter Base Plates:

7.2.3.1 *Total Absorption*—Plasticimeter base plates when immersed in water at room temperature for a period of 24 h shall absorb not less than 40 g of water. Before making the determination, dry the porcelain plates overnight in an oven at temperatures of between 100 and 110°C (212 and 230°F) and permit to cool to room temperature. Dry the plaster plates overnight over calcium chloride at room temperature. After immersion and before weighing, wipe off the excess water with a damp cloth.

7.2.3.2 *Rate of Absorption (Note 4)*—When tested over an area 70 mm (2¾ in.) in diameter, the water absorbed shall be in accordance with the following:

Time, min	Water Absorbed, mL
1	8 to 14
2	5 to 7½
3	4 to 6½
4	4 to 6
5	3½ to 5½

NOTE 4—A convenient apparatus for determining the rate of absorption consists of a buret sealed onto an inverted glass funnel from which the stem has been removed. The diameter of the larger end of the funnel shall be ground so as to be 70 mm (2¾ in.) in internal diameter. The funnel may be attached to the plate on which the measurement is being made by melted paraffin. The paraffin should not be too hot. A little experience will indicate when it is of the proper consistency.

7.3 Plasticity Determination:

7.3.1 Lubricate a ring mold such as is described in 6.2.2 with a thin film of water, place on a porcelain base plate (see 7.2.2 and 7.2.3) or a disposable plaster base plate (see 7.2.3), fill with the paste which has been adjusted to standard consistency as described in 6.3.3, and strike off level. Remove the mold by raising it vertically without distorting the paste. Center the base plate and paste in the instrument and turn the carriage up by hand until the surface of the paste is in contact with the disk and the distance between the disk and the top of the base plate is 32 mm (1¼ in.). Throw the carriage into gear and start the motor. It is essential that the motor be started exactly 120 s after the first portion of the paste has been placed in the mold. Record the time when the first portion of paste is placed in the mold as zero time; the motor is therefore started at 2 min. Take care to protect the specimen from drafts during the test.

7.3.2 Record the scale reading at 1-min intervals until the test is completed. Consider the test complete when: (1) the scale reading reaches 100, (2) any reading is less than the one before, or (3) the scale reading remains constant for three consecutive readings (2 min) and the specimen has visibly ruptured or broken loose from the base plate. Note the time and the scale reading at the end of the test.

7.4 Calculation:

7.4.1 Calculate the plasticity figure as follows:

$$P = \sqrt{F^2 + (10T)^2} \quad (1)$$

⁹ The sole source of supply of the Emley Plasticimeter known to the committee at this time is Geotest Instrument Corporation, 910 University Place, Evanston, IL 60201, USA. If you are aware of alternative suppliers, please provide this information to ASTM International Headquarters. Your comments will receive careful consideration at a meeting of the responsible technical committee¹, which you may attend.

where

P = plasticity figure,

F = scale reading at the end of the test, and

T = time in minutes from the time when the first portion of paste was put in the mold to the end of the test.

7.5 Precision and Bias:

7.5.1 There are as yet insufficient analyzed data to permit preparation of a precision and bias statement for this test method. When data are collected and analyzed, precision and bias statements will be proposed.

8. Autoclave Expansion of Hydrated Lime

8.1 Significance and Use:

8.1.1 Expansion of pressed tablets of hydrated lime generally indicates the presence of unhydrated oxides of magnesium and calcium. The relation of the degree of expansion in this test method to field performance has not been determined.

8.2 Apparatus:

8.2.1 *Mold and Press*—A steel mold capable of producing a press tablet at least 0.032 m (1.25 in.) in diameter and 0.006 m (0.25 in.) thick, and able to sustain at least 88.9 kN (20 000 lbf) pressure from a suitable press. It should be provided with a release jig also.

8.2.2 *Autoclave*, capable of holding 1034 kPa (150 psi) for 2 h.

8.2.3 *Micrometer*, dial-type, capable of measuring 2.54 μ m (0.0001 in.).

8.2.4 *Microscope*, with graduated lens for measuring 0.10 mm.

8.3 Procedure:

8.3.1 Weigh out 15 g of hydrated sample, place in the mold, and press into a tablet. Press to 33.4 kN (7500 lbf) for 10 s, then increase pressure to 88.9 kN (20 000 lbf) or more. Hold for 10 s before releasing. Press tablet from mold with jig and draw three diameter lines across the surface of the tablet using a lead pencil. Draw two diameter lines normal to each other and draw the third bisecting the 90° angles of the other two. Measure the diameters with a dial micrometer and place the tablet on the autoclave rack. Use aluminum foil to protect the tablets from water dripping. Autoclave at 862 to 1034 kPa (125 to 150 psi) for 2 h. Begin timing when the pressure reaches 345 kPa (50 psi). After the autoclaving interval, allow the autoclave to cool, remove the tablet, and remeasure the diameters. Calculate the average percent expansion of the tablet from the before and after measurements.

8.4 Expansion of Hydrated Lime-Portland Cement-Aggregate:

8.4.1 Materials:

8.4.1.1 *Standard Cement*—Type I or Type II portland cement.

8.4.1.2 *Standard Aggregate*—Pulverized limestone, minus 212- μ m (No. 70) sieve, having less than 0.5 % silicon dioxide (SiO₂).

8.4.2 Procedure:

8.4.2.1 *Test Tablet*—Make up a pressed tablet in accordance with the procedure outlined in 8.3.1 using the following mixture for the sample:

Standard portland cement

14 g

Hydrated lime 8 g
Standard aggregate (pulverized limestone) 72 g

Blend the mix until homogeneous.

8.4.2.2 *Standard Tablet*—Make up a pressed tablet in accordance with the procedure outlined in 8.3.1 using the following mixture for the sample:

Standard portland cement 7 g
Standard aggregate (pulverized limestone) 16 g

Blend the mix until homogeneous.

8.4.2.3 Autoclave and calculate expansions of the test tablet and the standard tablet in accordance with 8.3.1.

8.4.2.4 Determine the autoclave expansion of hydrated lime for masonry purposes by subtracting the average percent expansion of the standard tablet from the sample tablet.

8.5 Precision and Bias:

8.5.1 No precision data are available due to the limited use of this test method. Therefore, users are advised to develop their own laboratory precision. No statement is being made about the bias of this test method.

9. Popping and Pitting of Hydrated Lime

9.1 Significance and Use:

9.1.1 Pops and pits are caused by the hydration and expansion of coarse particles of unhydrated lime or lime-impurity reaction products present in the hydrated lime. The level of popping and pitting in the sample is indicative of the potential for the appearance of surface defects in plastering applications.

9.2 Gauging Plaster:

9.2.1 The gauging plaster used for the popping and pitting test shall conform to the Test Methods section of Specification C 28 and shall have a setting time of not more than 1 h when tested in accordance with Test Methods C 472. Test the gauging plaster without lime in the manner described in 9.3 to ensure its freedom from pops and pits. If any pops or pits are found, provide another lot of gauging plaster that is free of pops and pits when subjected to this test.

9.3 Procedure:

9.3.1 Mix 100 g of hydrated lime with sufficient water to bring to such a consistency as to give a penetration of 20 \pm 5 mm when tested in accordance with 6.3.3. Mix into this putty, 25 g of gauging plaster (9.2.1), adding more water as required to maintain workable consistency. Spread on a glass plate to make a pat at least 150 by 200 mm (6 by 8 in.) by approximately 3 mm ($\frac{1}{8}$ in.) in thickness. Trowel to a smooth finish. Allow to stand overnight.

9.3.2 Place the specimen and plate on a rack in the steam bath so that water is not in contact with the specimen to be tested. Provide a sloping cover above the specimen to prevent condensed steam from dripping onto the surface of the specimen. Raise the temperature of the water in the steam bath to boiling and maintain at boiling for 5 h. Remove the specimens from the bath and examine for pops and pits.

9.3.3 The pitting potential of hydrated lime can be determined in conjunction with autoclave expansion as in 8.3.1. However, it is not necessary to measure diameter, if only the pitting potential is to be determined. After following the procedure for expansion in 8.3.1, examine the pressed tablet



under the measuring microscope, and count and measure the pits in millimetres.

10. Water Retention of Hydrated Lime

10.1 Significance and Use:

10.1.1 This test method measures the ability of the hydrated lime in a plastic mix with sand to retain water, and hence retain consistency of the mix, when subjected to an applied suction. This ability, measured as a percent of the original consistency, is indicative of the workability to be expected in a masonry containing the lime.

10.2 Proportioning and Mixing:

10.2.1 *Apparatus*—The apparatus used shall conform to Practice C 305.

10.2.2 *Proportions*—The mortar tested shall be composed of 500 g of lime and 1500 g of standard sand conforming to 13.2.4. If hydrated lime putty is used, use that weight of putty that is equivalent to 500 g of dry hydrated lime.

10.2.3 Mechanical Mixing:

10.2.3.1 Place the dry paddle and the dry bowl in the mixing position in the mixer.

10.2.3.2 Place a measured quantity of water in the bowl.

10.2.3.3 Add the lime to the water, then start the mixer and mix at slow speed (140 ± 5 r/min) for 30 s.

10.2.4 Add the entire quantity of sand slowly over a 30-s period while mixing at slow speed.

10.2.5 Stop the mixer, change to medium speed (285 ± 10 rpm) and mix for 30 s.

10.2.6 Stop the mixer and let the mortar stand for $1\frac{1}{2}$ min. (During the first 15 s of this interval, quickly scrape down into the batch any mortar that may have collected on the side of the bowl, then for the remainder of this interval cover the bowl with the lid.)

10.2.7 Finish the mixing for 1 min at medium speed.

10.2.8 In any case requiring a remixing interval, any mortar adhering to the side of the bowl shall be quickly scraped down into the batch prior to remixing.

10.3 Consistency:

10.3.1 *Apparatus*—The flow table and mold used for the measurement of consistency of the mortar shall conform to Specification C 230.

10.3.2 *Procedure*—Carefully wipe dry the flow table top and place the flow mold at the center. Immediately after completing the mixing operation, fill the mold with mortar gently pressed into place by the finger tips to ensure uniform filling free of voids. Smooth off the mortar level with the top of the mold by aid of a trowel, and remove the mold. Immediately drop the table through a height of 13 mm ($\frac{1}{2}$ in.), 25 times in 15 s. The flow is the resulting increase in diameter of the mortar mass, expressed as the percentage of the original diameter. The mortar may be adjusted, if the flow is below 100 %, by additions of water until the flow is within the range from 100 to 115 %. Make each adjustment by returning the mortar to the original mixing bowl, add water, and then mix at medium speed (285 ± 10 r/min) for 30 s. If the flow of the original mortar is greater than 115 %, prepare a new batch.

10.4 Water Retention Test:

10.4.1 *Apparatus*—The equipment used to determine water retention shall conform to either apparatus used for the water

retention test in Specification C 91 (see Figs. 3 and 4).

10.4.2 Procedure:

10.4.2.1 Adjust the mercury relief column or vacuum regulator to maintain a vacuum of 51 ± 3 mm as measured on the manometer or the vacuum gauge. Seat the perforated dish on the greased gasket of the funnel. Place a wetted filter paper in the bottom of the dish. Turn the stopcock to apply the vacuum to the funnel and check the apparatus for leaks and to determine that the required vacuum is obtained. Then turn the stopcock to shut off the vacuum from the funnel.

10.4.2.2 Immediately after the final consistency test (10.3.2), return all of the mortar to the bowl and remix the entire batch for 15 s at medium speed. Immediately after remixing the mortar, fill the perforated dish with the mortar to slightly above the rim. Tamp the mortar 15 times with the tamper. Apply ten of the tamping strokes at approximately uniform spacing adjacent to the rim of the dish and with the long axis of the tamping face held at right angles, to the radius of the dish. Apply the remaining five tamping strokes at random points distributed over the central area of the dish. The tamping pressure shall be just sufficient to ensure filling of the dish. On completion of the tamping, the top of the mortar should extend slightly above the rim of the dish. Smooth off the mortar by drawing the flat side of the straightedge (with the leading edge slightly raised) across the top of the dish. Then cut off the mortar to a plane surface flush with the rim of the dish by drawing the straightedge with a sawing motion across the top of the dish in two cutting strokes, starting each cut near the center of the dish. If the mortar is pulled away from the side of the dish during the process of cutting off the excess mortar, gently press the mortar back into contact with the side of the dish using the tamper.

10.4.2.3 Turn the stopcock to apply vacuum to the funnel. After suction for 60 s, quickly turn the stopcock to expose the funnel to atmospheric pressure. Immediately slide the perforated dish off the funnel, touch it momentarily on a damp cloth to remove droplets of water, and set the dish on the table. Then using the bowl scraper (rubber scraper as specified in Practice C 305), plow and mix the mortar in the dish for 15 s. Upon completion of mixing, place the mortar in the flow mold and determine the flow. Carry out the entire operation without interruption and as quickly as possible. Not more than 30 min should be required for completion, starting from the completion of the mixing of the mortar for the first flow determination.

10.4.3 Calculation:

10.4.3.1 Calculate the water retention value for the mortar as follows:

$$\text{Water retention value} = (A/B) \times 100 \quad (2)$$

where:

A = flow after suction, and

B = flow immediately after mixing.

10.5 Precision and Bias:

10.5.1 No precision data are available due to the limited use of this test method. Therefore, users are advised to develop their own laboratory precision.

11. Settling Rate of Hydrated Lime

11.1 Significance and Use:

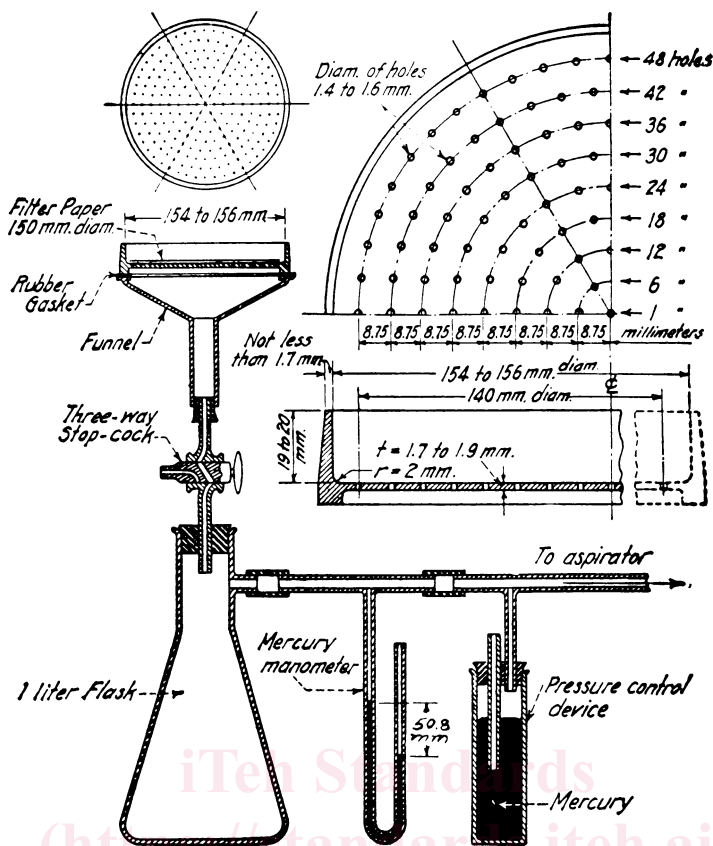

FIG. 3 Apparatus Assembly for the Water Retention Test

11.1.1 This test method provides a measure of the rate of settling of a hydrated lime slurry, a form in which this material is frequently used. In some applications a slow settling slurry is desirable; in others, fast settling is preferred.

11.2 Procedure:

11.2.1 Place 10.0 g of lime hydrate in a 100-mL glass-stoppered graduated cylinder (internal diameter about 24 mm). Wet with 50 mL of carbon dioxide (CO₂) free distilled water at 23 ± 1.7°C (73.4 ± 3°F) and mix thoroughly by alternately inverting and righting the cylinder slowly for a period of 2 min. Allow the graduate and contents to stand at 23 ± 1.7°C for 30 min and then dilute to the 100-mL mark with CO₂-free distilled water at 23 ± 1.7°C. Mix contents again thoroughly as before and allow to stand undisturbed at 23 ± 1.7°C for 24 h.

11.3 Report:

11.3.1 Report the sedimentation height in millilitres after ¼, ½, ¾, 1, 2, 4, and 24 h, reading the bottom of the meniscus.

NOTE 5—Slight variations in results of this test method on a sample run in different laboratories or by different operators are permissible. The test is not an absolute one, but is designed to distinguish between fast and slow settling hydrates.

11.4 Precision and Bias:

11.4.1 No precision data are available due to the limited use of this test method. Therefore, users are advised to develop their own laboratory precision.

12. Slaking Rate of Quicklime

12.1 Significance and Use:

12.1.1 The temperature rise in 30 s is a measure of the

reactivity of the softer-burned portion of the quicklime. Total slaking time provides a measure of the overall degree of reactivity of the material. Total temperature rise is largely dependent on the available lime content of the sample.

12.1.2 These slaking parameters provide an indication of the performance of the quicklime to be expected in industrial slaking systems. Slaking characteristics have an effect on lime slurry properties such as settling characteristics, viscosity, particle size, and reaction rate.

12.2 Apparatus:

12.2.1 Mechanical Stirrer¹⁰, speed 400 ± 50 r/min, fitted with a special stirring rod.

12.2.2 Modified Dewar Flask¹¹, 665-mL, fitted with special rubber gasket covers.

12.2.3 Thermometer, dial-type, 0 to 100°C range in 1°C increments or thermocouple with a response time equivalent to or faster than the dial thermometer.

12.2.4 Torsion Balance.

12.2.5 Sieve, 203-mm (8-in.), 3.35-mm (No. 6), conforming to Specification E 11.

12.2.6 An apparatus essentially the same as that illustrated in Fig. 5 and Fig. 6 shall be used. The apparatus consists of a covered reaction container fitted with a mechanical stirrer and thermometer. The quicklime charge shall be stirred with a mechanical stirrer fitted with a stainless steel rod, the end of which is formed into a loop to follow the contour of the

12.2 Apparatus:

12.2.1 Mechanical Stirrer¹⁰, speed 400 ± 50 r/min, fitted with a special stirring rod.

12.2.2 Modified Dewar Flask¹¹, 665-mL, fitted with special rubber gasket covers.

12.2.3 Thermometer, dial-type, 0 to 100°C range in 1°C increments or thermocouple with a response time equivalent to or faster than the dial thermometer.

12.2.4 Torsion Balance.

12.2.5 Sieve, 203-mm (8-in.), 3.35-mm (No. 6), conforming to Specification E 11.

12.2.6 An apparatus essentially the same as that illustrated in Fig. 5 and Fig. 6 shall be used. The apparatus consists of a covered reaction container fitted with a mechanical stirrer and thermometer. The quicklime charge shall be stirred with a mechanical stirrer fitted with a stainless steel rod, the end of which is formed into a loop to follow the contour of the

¹⁰ A Fisher 14-498, or equivalent, has been found suitable for this purpose.

¹¹ A Fisher 10-197, or equivalent, has been found suitable for this purpose.

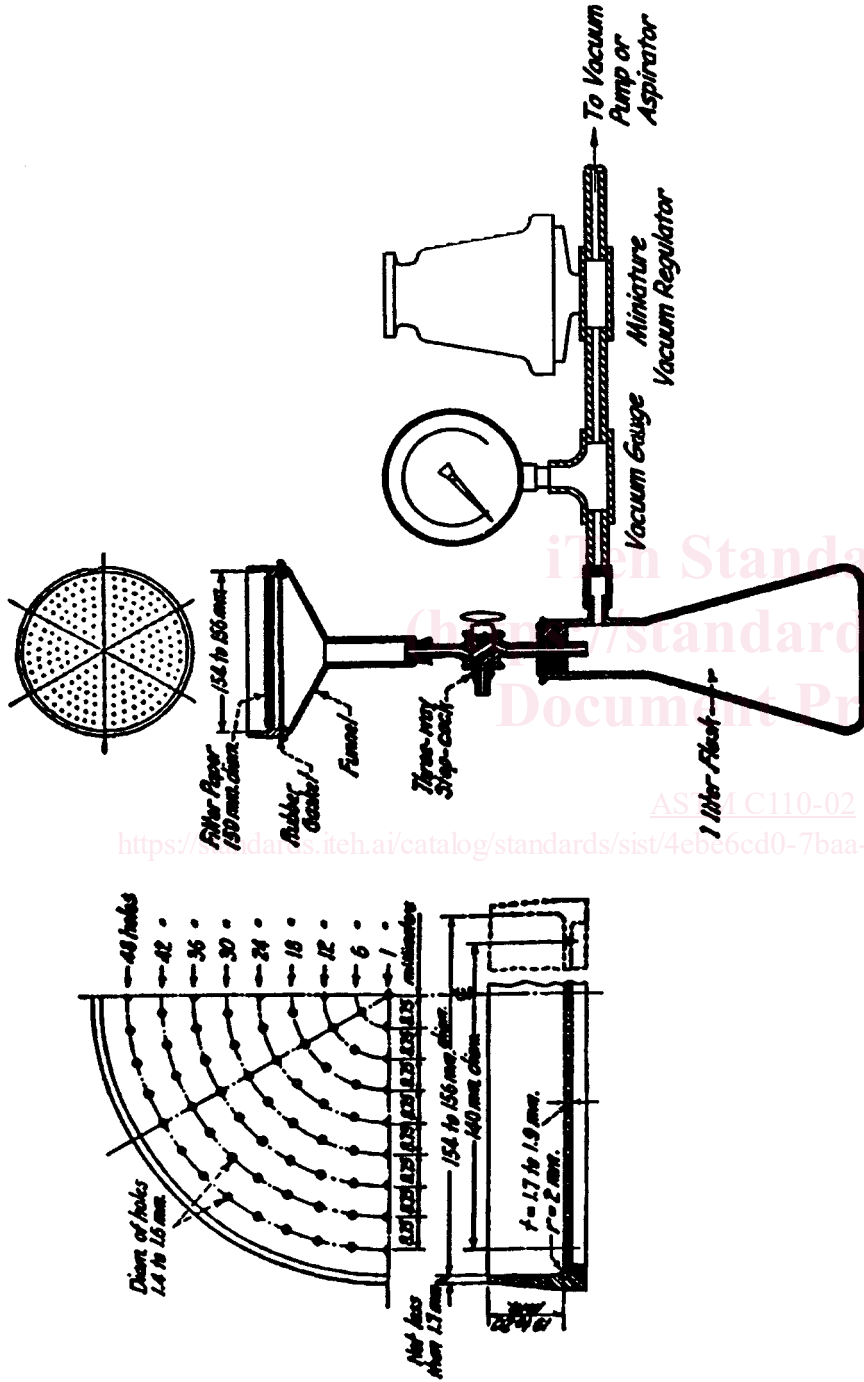

FIG. 4 Vacuum Gauge Apparatus Assembly for the Water Retention Test

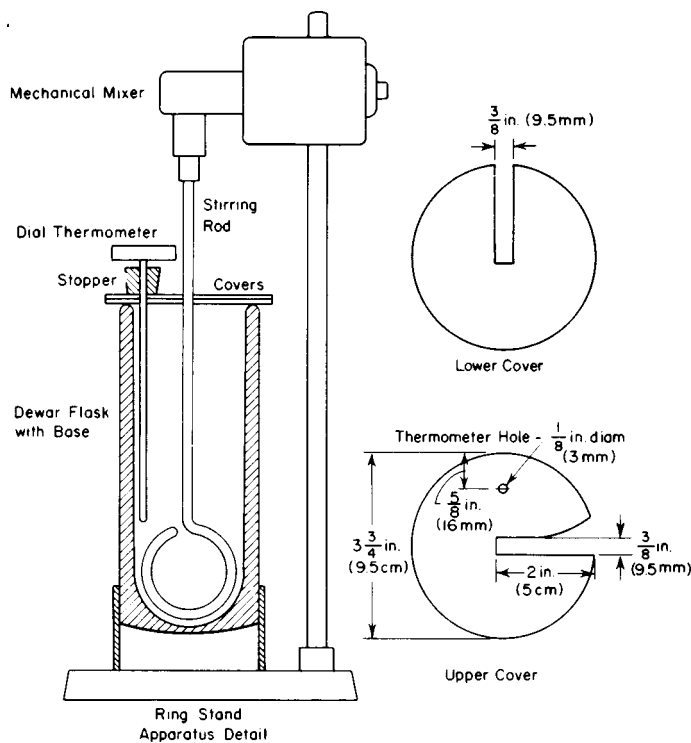

FIG. 5 Slaking Reactivity Apparatus

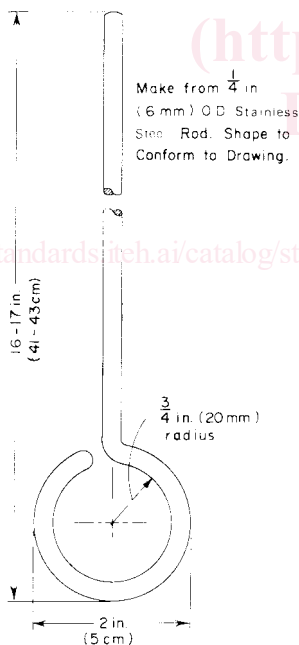

FIG. 6 Stirring Rod Detail

reaction container. The vacuum reaction flask shall be provided with a cover consisting of two circular pieces of gasket rubber sheet, approximately 3 mm ($\frac{1}{8}$ in.) thick. The first piece is provided with a single radial slot that slides over the stirring rod and the thermometer. The second piece (top) has a similar slot plus a hole to provide for the dial thermometer. When the two cover pieces are in place, the slot on the lower piece is at right angles to the slot on the upper piece with the thermometer stem extending through the lower slot. The apparatus may be assembled by any convenient supporting equipment.

12.3 Procedure:

12.3.1 Prepare the sample of quicklime (as rapidly as possible to prevent sample deterioration) so that a majority of the material passes a 3.35 mm (No. 6) sieve. Place the sample in an airtight container and allow to come to room temperature before testing. The slaking rate of lime is significantly affected by the particle size of the sample and must be as close to a 3.35 mm (No. 6) sieve as possible. It is not necessary that 100 % of the sample pass a 3.35 mm (No. 6) sieve, but all of the sample, including the plus 3.35 mm (plus No. 6) fraction, must be used in the test.

12.3.2 *Slaking Rate*—Adjust the temperature of about 500 mL of distilled water in accordance with the schedule given in Table 1, and add the specified amount to the Dewar flask. Set the agitator revolving at 400 ± 50 r/min. The temperature of the water in the flask must be $\pm 0.5^\circ\text{C}$ of the desired temperature. Quarter and weigh out the required amount of the prepared quicklime sample. Add the quicklime to the water without delay and simultaneously begin timing. Put the covers in place immediately. Take a reading at each 30 s interval.

12.3.3 Continue readings until less than 0.5°C temperature change is noted in each of three consecutive readings. The total active slaking time will then be the time at which the first of the three consecutive readings was taken. The temperature at this time will be considered the final reaction temperature. Subtract

TABLE 1 Schedule for Slaking Rate

	Material to Be Tested	
	Dolomitic	High Calcium
Temperature of water, $^\circ\text{C}$	40	25 ^A
Quantity of water, mL	400	400
Quantity of quicklime, g	120	100

^AInitial temperature of 40°C may be used, provided the report of results states the initial temperature.

the initial temperature from the final temperature to obtain the total temperature rise. Subtract the initial temperature from the temperature at 30 s for the temperature rise in 30 s. Subtract the initial temperature from the temperature at 3 min for the temperature rise in 3 min.

12.4 Report:

12.4.1 Record the actual temperature rise and plot a suitable curve showing temperature rise as the ordinate and time as the abscissa. The results may also be reported as:

12.4.1.1 Temperature rise in 30 s (or at any other designated time) in degrees Celsius,

12.4.1.2 Total temperature rise in degrees Celsius, and

12.4.1.3 Total active slaking time in minutes.

12.5 Precision and Bias:

12.5.1 Twelve laboratories cooperated in the testing of five high calcium quicklimes and four dolomitic quicklimes thereby obtaining the repeatability (*r*) and reproducibility (*R*) (Practice E 691) data contained in Table 2.

12.5.2 Due to the lack of a recognized industry standard, the bias of this test method has not been determined. The variety of reporting options also complicates obtaining a suitable bias statement.

13. Air Entrainment

13.1 Significance and Use:

13.1.1 Hydrated lime, particularly that containing an air-entraining additive, used in masonry mortar may contribute to the air content of the mortar. Certain specifications and applications of mortar place a limit on this air content.

13.2 Apparatus:

13.2.1 *Scales, Sieves, Glass Graduates, Tamper, Measure, Straightedge, Spatula, Tapping Stick, and Spoon*, conforming to the requirements given in Test Method C 185.

13.2.2 *Flow Table*, conforming to the requirements prescribed in Specification C 230.

13.2.3 *Mixing Apparatus*, conforming to the requirements as prescribed in Practice C 305.

13.2.4 The sand shall be a blend of equal parts by weight of graded Ottawa sand and standard 20–30 Ottawa sand. The fineness of graded Ottawa sand and standard 20–30 sand may be checked by using the methods described in Specification C 778.

13.3 Preparation of Mortar:

13.3.1 *Proportions for Mortar*—Portland cement-hydrated lime mortar for measurement of air entrainment shall be proportioned to conform, in batch size, to the unit weights by volume of cementitious material and aggregate as shown in Table 3. The portland cement shall conform to Specification C 150, and the hydrated lime to Specification C 207. The quantity of water, measured in millilitres, shall be such as to

TABLE 2 Precision Data

Material	Labs	Results in °C Rise		<i>r</i>	<i>R</i>
		Time	Range Tested		
High Calcium	12	30 s	12.3–44.4	1.56	4.21
High Calcium	11	3 min	32.1–56.1	1.72	4.72
Dolomitic	10	30 s	3.6–12.0	1.38	2.84
Dolomitic	9	3 min	21.2–36.4	1.62	3.72

TABLE 3 Unit Weights and Apparent Specific Gravities

Materials	Unit weight, kg/m ³ (lb/ft ³) ^A	Specific Gravity
Portland cement	1,504 (94)	3.15
Hydrated lime	800 (50)	2.30
Blended Ottawa sand	1,280 (80)	2.65

^AThe unit weight values listed for cementitious materials are assumed values commonly used in construction practice.

produce a flow of 110 ± 5 % as determined by the flow table. Proportions for the generally used batch sizes based on Table 2 material unit weight shall contain the weights as prescribed in Table 4.

13.3.2 *Mixing of Mortars*—Mix the mortar in accordance with the procedure for mixing pastes in Practice C 305.

13.3.3 *Determination of Flow*—Determine the flow in accordance with the Procedure section of Test Method C 109.

13.4 Procedure:

13.4.1 If the mortar has the correct flow, use a separate portion of the mortar for the determination of entrained air. Determine the weight of 400 mL of mortar in accordance with Test Method C 185.

13.5 Calculation:

13.5.1 Calculate the air content of the mortar and report it to the nearest 0.1 % as follows:

$$D = (W_1 + W_2 + W_3 + V_w) / [(W_1/S_1) + (W_2/S_2) + (W_3/S_3) + V_w]A = 100 - (W_m/4D) \tag{3}$$

where:

- D* = density of air-free mortar,
- W*₁ = weight of portland cement, g,
- W*₂ = weight of hydrated lime, g,
- W*₃ = weight of blended Ottawa sand, g,
- V*_w = water used, mL,
- S*₁ = specific gravity of portland cement,
- S*₂ = specific gravity of hydrated lime,
- S*₃ = specific gravity of blended Ottawa sand,
- A* = volume % of entrained air, and
- W*_m = weight of 400 mL of mortar, g.

NOTE 6—For lime/sand mortars, *W*₁ and *S*₁ should be dropped from the calculation.

13.6 Precision and Bias:

13.6.1 The single operator within laboratory standard deviation has been found to be 0.56 % air content throughout the range of 8 % to 19 % air content. Therefore results of two properly conducted tests by the same operator on similar batches of mortar should not differ by more than 1.6 % air content.

13.6.2 The multilaboratory standard deviation has been found to be 1.0 % air content throughout the range of 8 % to

TABLE 4 Weight of Materials for Mortar Batch

Mortar Type	Proportions by Volume	Portland Cement (g)	Hydrated Lime (g)	Blended Ottawa Silica Sand (g)
M	1:¼:3¾	470.0	62.5	1,500
S	1:½:4½	376.0	100.0	1,440
N	1:1:6	282.0	150.0	1,440
O	1:2:9	188.0	200.0	1,440
Lime/Sand	1:3		300.0	1,400