



SLOVENSKI STANDARD
SIST EN 4012:2004

01-maj-2004

Aerospace series - Nuts, bihexagonal, self-locking, in heat resisting nickel base alloy NI-P100HT (Inconel 718), MoS2 coated - Classification: 1 500 MPa (at ambient temperature)/425°C

Aerospace series - Nuts, bihexagonal, self-locking, in heat resisting nickel base alloy NI-P100HT (Inconel 718), MoS2 coated - Classification: 1 500 MPa (at ambient temperature)/425°C

iTeh STANDARD PREVIEW
(standards.iteh.ai)

[SIST EN 4012:2004](https://standards.iteh.ai/catalog/standards/sist/cebf8893-5d26-4c64-aad2-2bb52ff3854e/sist-en-4012-2004)

<https://standards.iteh.ai/catalog/standards/sist/cebf8893-5d26-4c64-aad2-2bb52ff3854e/sist-en-4012-2004>

Ta slovenski standard je istoveten z: EN 4012:2003

ICS:

49.030.30 Matice Nuts

SIST EN 4012:2004 en

iTeh STANDARD PREVIEW
(standards.iteh.ai)

[SIST EN 4012:2004](#)

<https://standards.iteh.ai/catalog/standards/sist/ceb8893-5d26-4c64-aad2-2bb52ff3854e/sist-en-4012-2004>

EUROPEAN STANDARD
NORME EUROPÉENNE
EUROPÄISCHE NORM

EN 4012

January 2003

ICS 49.030.30

English version

Aerospace series - Nuts, bihexagonal, self-locking, in heat resisting nickel base alloy NI-P100HT (Inconel 718), MoS₂ coated - Classification: 1 500 MPa (at ambient temperature)/425°C

This European Standard was approved by CEN on 2 June 2002.

CEN members are bound to comply with the CEN/CENELEC Internal Regulations which stipulate the conditions for giving this European Standard the status of a national standard without any alteration. Up-to-date lists and bibliographical references concerning such national standards may be obtained on application to the Management Centre or to any CEN member.

This European Standard exists in three official versions (English, French, German). A version in any other language made by translation under the responsibility of a CEN member into its own language and notified to the Management Centre has the same status as the official versions.

CEN members are the national standards bodies of Austria, Belgium, Czech Republic, Denmark, Finland, France, Germany, Greece, Hungary, Iceland, Ireland, Italy, Luxembourg, Malta, Netherlands, Norway, Portugal, Slovakia, Spain, Sweden, Switzerland and United Kingdom.

<https://standards.iteh.ai/catalog/standards/sist/ceb8893-5d26-4c64-aad2-2bb52ff3854e/sist-en-4012-2004>



EUROPEAN COMMITTEE FOR STANDARDIZATION
COMITÉ EUROPÉEN DE NORMALISATION
EUROPÄISCHES KOMITEE FÜR NORMUNG

Management Centre: rue de Stassart, 36 B-1050 Brussels

Contents

page

Foreword.....	3
1 Scope	3
2 Normative references	3
3 Required characteristics	4
3.1 Configuration - Dimensions - Tolerances – Masses	4
3.2 Material.....	4
3.3 Surface coating	4
4 Designation.....	5
5 Marking	5
6 Technical specification	5

iTeh STANDARD PREVIEW
(standards.iteh.ai)

[SIST EN 4012:2004](https://standards.iteh.ai/catalog/standards/sist/cebf8893-5d26-4c64-aad2-2bb52ff3854e/sist-en-4012-2004)

<https://standards.iteh.ai/catalog/standards/sist/cebf8893-5d26-4c64-aad2-2bb52ff3854e/sist-en-4012-2004>

Foreword

This document (EN 4012:2003) has been prepared by the European Association of Aerospace Manufacturers – Standardization (AECMA-STAN).

After enquiries and votes carried out in accordance with the rules of this Association, this Standard has received the approval of the National Associations and the Official Services of the member countries of AECMA, prior to its presentation to CEN.

This European Standard shall be given the status of a national standard, either by publication of an identical text or by endorsement, at the latest by July 2003, and conflicting national standards shall be withdrawn at the latest by July 2003.

According to the CEN/CENELEC Internal Regulations, the national standards organizations of the following countries are bound to implement this European Standard: Austria, Belgium, Czech Republic, Denmark, Finland, France, Germany, Greece, Hungary, Iceland, Ireland, Italy, Luxembourg, Malta, Netherlands, Norway, Portugal, Slovakia, Spain, Sweden, Switzerland and the United Kingdom.

1 Scope

This standard specifies the characteristics of self-locking bihexagonal nuts in NI-P100HT, MoS₂ coated, for aerospace applications.

iTeh STANDARD PREVIEW
(standards.iteh.ai)

Classification : 1 550 MPa ¹⁾ / 425 °C ²⁾

[SIST EN 4012:2004](#)

<https://standards.iteh.ai/catalog/standards/sist/cebfb8893-5d26-4c64-aad2-2bb52fb3854e/sist-en-4012-2004>

2 Normative references

- | | |
|------------|--|
| ISO 4095 | Fasteners for aerospace construction - Bi-hexagonal wrenching configuration |
| ISO 5855-2 | Aerospace - MJ threads - Part 2 : Limit dimensions for bolts and nuts |
| EN 2424 | Aerospace series – Marking of aerospace products |
| EN 2491 | Aerospace series – Molybdenum disulphide dry lubricants – Coating methods |
| EN 2952 | Aerospace series – Heat resisting alloy NI-PH2601 – Solution treated and cold worked – Bar for forged fasteners – $D \leq 50$ mm – $1270 \text{ MPa} \leq R_m \leq 1550 \text{ MPa}$ ³⁾ |
| EN 4048 | Aerospace series – Nuts, self-locking, MJ threads, in heat resisting nickel base alloy NI-PH2601 (Inconel 718), MoS ₂ coated – Classification: 1 550 MPa (at ambient temperature) /425 °C – Technical specification ³⁾ |

1) The strength class of the bolt concerned which can withstand the load at ambient temperature when tested at 100 % load without cracking or breaking of the nut.

2) Maximum test temperature of the parts

3) Published as AECMA Prestandard at the date of publication of this standard

3 Required characteristics

3.1 Configuration - Dimensions - Tolerances – Masses

See figure 1 and table 1. Dimensions and tolerances are in millimetres. They apply before surface coating.

3.2 Material

EN 2952

3.3 Surface coating

EN 2491

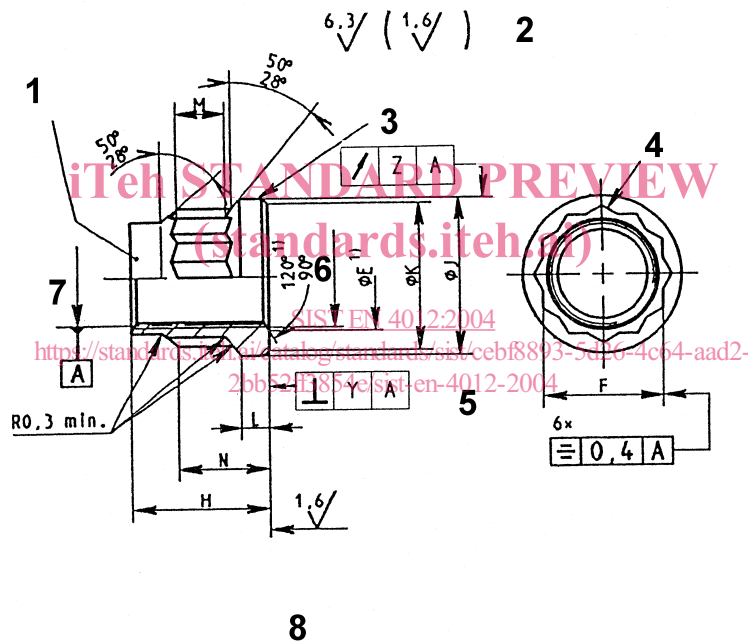

Key

- 1 Form out-of-round in this area to achieve the self-locking requirement. (tooling marks permissible)
 - 2 Values applicable before lubrication. Thread surface will be as achieved by normal methods of manufacture.
 - 3 Marking
 - 4 Bihexagonal configuration in accordance with ISO 4095 over length M
 - 5 Not convex
 - 6 Thread
 - 7 Pitch diameter
 - 8 Remove sharp edges 0,1 to 0,4
- Details of form not stated are left to the manufacturer's discretion.

¹⁾ All forms of entry (radius or chamfer) are permissible within these limiting dimensions.

Figure 1

Table 1

Code	Thread ^{*)} Designation	E		F	H max.	J max.	K min.	L min.	M min.	N max.	Y	Z	Mass kg/10 00 parts ≈
		max.	min.										
050	MJ5X0,8-4H6H	5,8	5,2	7	7	9,1	8,3	1,2	2	4,9	0,1	0,2	1,68
060	MJ6X1-4H5H	7,1	6,3	8	8,1	10,6	9,8		2,3	5,5			2,4
070	MJ7X1-4H5H	8,1	7,3	9	9,1	12,1	11,3		2,6	6,1			3,29
080	MJ8X1-4H5H	9,1	8,3	10	10,4	13,6	12,8		2,8	6,9			4,47
100	MJ10X1,25-4H5H	11,1	10,3	12	13	16,8	15,8		3,1	8,8			7,92
120	MJ12X1,25-4H5H	13,1	12,3	14	15	19,9	18,8	1,4	3,5	10,1	0,13	0,3	15,02
140	MJ14X1,5-4H5H	15,2	14,4	17	17,5	23	21,9	1,7	4	12,6	0,15		20,38

*) In accordance with ISO 5855-2. In the self-locking zone, the tolerance apply before forming out-of-round.

4 Designation

EXAMPLE :

Description block

Identity block

NUT

EN4012 -050

Number of this standard

Thread code (see table 1)

ITeH STANDARD PREVIEW
(standards.iteh.ai)

NOTE: If necessary, the code I9005 shall be placed between the description block and the identity block.

[SIST EN 4012:2004](https://standards.iteh.ai/catalog/standards/sist/ceb8893-5d26-4c64-aad2-2bb52f3854e/sist-en-4012-2004)

<https://standards.iteh.ai/catalog/standards/sist/ceb8893-5d26-4c64-aad2-2bb52f3854e/sist-en-4012-2004>

5 Marking

EN 2424, style A, as indicated on figure 1.

6 Technical specification

EN 4048