



SLOVENSKI STANDARD

SIST EN 4119:2004

01-maj-2004

Aerospace series - Nuts, bihexagonal, self-locking, deep counterbored, in heat resisting steel FE-PA92HT (A286), silver plated on thread - Classification: 1 100 MPa (at ambient temperature) / 650°C

Aerospace series - Nuts, bihexagonal, self-locking, deep counterbored, in heat resisting steel FE-PA92HT (A286), silver plated on thread - Classification: 1 100 MPa (at ambient temperature) / 650°C

iTeh STANDARD PREVIEW
(standards.iteh.ai)

[SIST EN 4119:2004](https://standards.iteh.ai/catalog/standards/sist/f8a5d293-264b-42d5-bbfd-5ae100745cfe/sist-en-4119-2004)

[https://standards.iteh.ai/catalog/standards/sist/f8a5d293-264b-42d5-bbfd-](https://standards.iteh.ai/catalog/standards/sist/f8a5d293-264b-42d5-bbfd-5ae100745cfe/sist-en-4119-2004)

[5ae100745cfe/sist-en-4119-2004](https://standards.iteh.ai/catalog/standards/sist/f8a5d293-264b-42d5-bbfd-5ae100745cfe/sist-en-4119-2004)

Ta slovenski standard je istoveten z: EN 4119:2003

ICS:

49.030.30 Matice Nuts

SIST EN 4119:2004 en

iTeh STANDARD PREVIEW
(standards.iteh.ai)

SIST EN 4119:2004

<https://standards.iteh.ai/catalog/standards/sist/f8a5d293-264b-42d5-bbfd-5ae100745cfe/sist-en-4119-2004>

EUROPEAN STANDARD
NORME EUROPÉENNE
EUROPÄISCHE NORM

EN 4119

January 2003

ICS 49.030.30

English version

Aerospace series - Nuts, bihexagonal, self-locking, deep counterbored, in heat resisting steel FE-PA92HT (A286), silver plated on thread - Classification: 1 100 MPa (at ambient temperature) / 650°C

This European Standard was approved by CEN on 2 June 2002.

CEN members are bound to comply with the CEN/CENELEC Internal Regulations which stipulate the conditions for giving this European Standard the status of a national standard without any alteration. Up-to-date lists and bibliographical references concerning such national standards may be obtained on application to the Management Centre or to any CEN member.

This European Standard exists in three official versions (English, French, German). A version in any other language made by translation under the responsibility of a CEN member into its own language and notified to the Management Centre has the same status as the official versions.

CEN members are the national standards bodies of Austria, Belgium, Czech Republic, Denmark, Finland, France, Germany, Greece, Hungary, Iceland, Ireland, Italy, Luxembourg, Malta, Netherlands, Norway, Portugal, Slovakia, Spain, Sweden, Switzerland and United Kingdom.

<https://standards.iteh.ai/catalog/standards/sist/f8a5d293-264b-42d5-bbfd-5ae100745cfe/sist-en-4119-2004>



EUROPEAN COMMITTEE FOR STANDARDIZATION
COMITÉ EUROPÉEN DE NORMALISATION
EUROPÄISCHES KOMITEE FÜR NORMUNG

Management Centre: rue de Stassart, 36 B-1050 Brussels

Contents**page**

Foreword.....	3
1 Scope	3
2 Normative references	3
3 Required characteristics	4
3.1 Configuration - Dimensions - Tolerances – Masses	4
3.2 Materials.....	4
3.3 Surface treatment	4
4 Designation.....	6
5 Marking	6
6 Technical specification	6

iTeh STANDARD PREVIEW
(standards.iteh.ai)

[SIST EN 4119:2004](https://standards.iteh.ai/catalog/standards/sist/f8a5d293-264b-42d5-bbfd-5ae100745cfe/sist-en-4119-2004)

<https://standards.iteh.ai/catalog/standards/sist/f8a5d293-264b-42d5-bbfd-5ae100745cfe/sist-en-4119-2004>

Foreword

This document (EN 4119:2003) has been prepared by the European Association of Aerospace Manufacturers – Standardization (AECMA-STAN).

After enquiries and votes carried out in accordance with the rules of this Association, this Standard has received the approval of the National Associations and the Official Services of the member countries of AECMA, prior to its presentation to CEN.

This European Standard shall be given the status of a national standard, either by publication of an identical text or by endorsement, at the latest by July 2003, and conflicting national standards shall be withdrawn at the latest by July 2003.

According to the CEN/CENELEC Internal Regulations, the national standards organizations of the following countries are bound to implement this European Standard: Austria, Belgium, Czech Republic, Denmark, Finland, France, Germany, Greece, Hungary, Iceland, Ireland, Italy, Luxembourg, Malta, Netherlands, Norway, Portugal, Slovakia, Spain, Sweden, Switzerland and the United Kingdom.

1 Scope

This standard specifies the characteristics of self-locking bihexagonal nuts with deep counterbore in FE-PA92HT, silver plated on thread, for aerospace applications.

Classification: 1 100 MPa ¹⁾ / 650 °C ²⁾

SIST EN 4119:2004

<https://standards.iteh.ai/catalog/standards/sist/f8a5d293-264b-42d5-bbfd-5ae100745cfe/sist-en-4119-2004>

2 Normative references

- | | |
|------------|--|
| ISO 4095 | Aerospace - Bihexagonal drives - Wrenching configuration - Metric series |
| ISO 5855-2 | Aerospace - MJ threads - Part 2 : Limit dimensions for bolts and nuts |
| EN 2399 | Heat resisting steel FE-PA92-HT - $R_m \geq 900$ MPa - Bars for forged bolts - $D \leq 25$ mm - Aerospace series ³⁾ |
| EN 2424 | Aerospace series - Marking of aerospace products |
| EN 2786 | Aerospace series - Electrolytic silver plating of fasteners ⁴⁾ |
| EN 3004 | Aerospace series - Nuts, self-locking, MJ threads, in heat resisting steel FE-PA2601 (A286) - Classification : 1 100 MPa (at ambient temperature) / 650 °C - Technical specification |
| EN 3639 | Aerospace series - Heat resisting alloy FE-PA2601 - Softened and cold worked - Wire for forged fasteners - $D \leq 15$ mm - $900 \text{ MPa} \leq R_m \leq 1100 \text{ MPa}$ ⁴⁾ |

¹⁾ The strength class of the bolt concerned which can withstand the load at ambient temperature when tested at 100 % load without cracking or breaking of the nut.

²⁾ Maximum test temperature of the parts

³⁾ Published as AECMA Standard at the date of publication of this standard

⁴⁾ Published as AECMA Prestandard at the date of publication of this standard

EN 4119:2003 (E)

3 Required characteristics

3.1 Configuration - Dimensions - Tolerances – Masses

See figure 1 and table 1. Dimensions and tolerances are in millimetres. They apply after silver plating for thread surface.

3.2 Materials

EN 2399 or EN 3639

3.3 Surface treatment

EN 2786 on thread, counterbore and chamfers

Thickness :

- Thread \geq MJ6 : 5 μm min. on thread flanks;
- Thread MJ5 : shall show complete coverage, without thickness requirement;
- Counterbore and chamfers : shall show complete coverage, without thickness requirement.

iTeh STANDARD PREVIEW
(standards.iteh.ai)

[SIST EN 4119:2004](https://standards.iteh.ai/catalog/standards/sist/f8a5d293-264b-42d5-bbfd-5ae100745cfe/sist-en-4119-2004)

<https://standards.iteh.ai/catalog/standards/sist/f8a5d293-264b-42d5-bbfd-5ae100745cfe/sist-en-4119-2004>

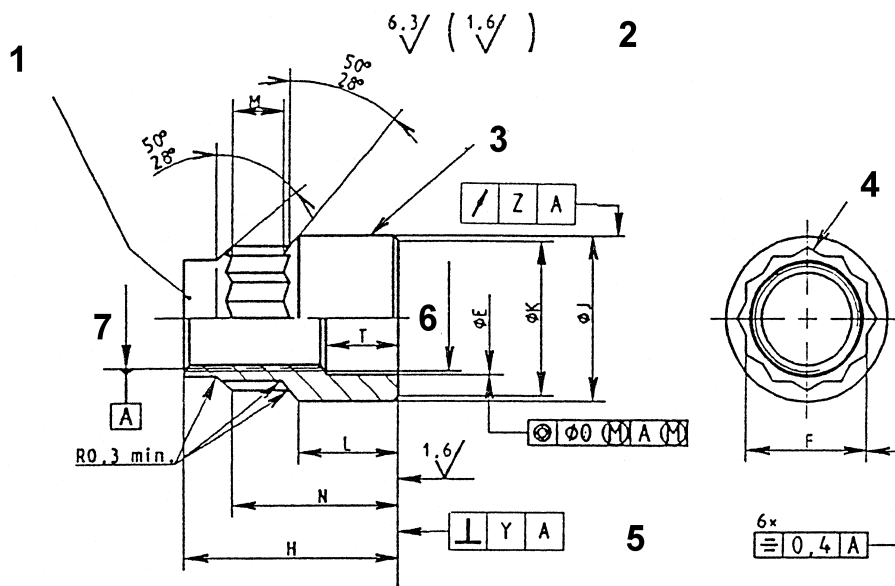

Key

iTeh STANDARD PREVIEW (standards.iteh.ai)

- 1 Form out-of-round in this area to achieve the self-locking requirement (tooling marks permissible)
- 2 Thread surface will be as achieved by normal methods of manufacture.
(Values apply before silver plating.)
- 3 Marking
- 4 Bihexagonal configuration in accordance with ISO 4095 over length M
- 5 not convex
- 6 Thread
- 7 Pitch diameter

Remove sharp edges 0,1 to 0,4

Details of form not stated are left to the manufacturer's discretion.

Figure 1

Table 1

Thread *)		E		F	H	J	K	L	M	N	T	Y	Z	Mass kg/1000 parts ≈
Code	Designation	max	min.		max.	max.	min.	min.	min.	max.	±0,2			
050	MJ 5x 0,8-4H6H	5,8	5,2	7	11,5	9,1	8,3	5,7	2	9,4	4,5	0,1	0,2	2,87
060	MJ 6x1-4H5H	7,1	6,3	8	12,9	10,6	9,8	5,95	2,3	10,3	4,75			3,98
070	MJ 7x1-4H5H	8,1	7,3	9	14,1	12,1	11,3	6,2	2,6	11,1	5			4,95
080	MJ 8x1-4H5H	9,1	8,3	10	15,7	13,6	12,8	6,45	2,8	12,2	5,25			6
100	MJ 10x1,25-4H5H	11,1	10,3	12	18,5	16,8	15,8	6,7	3,1	14,3	5,5	0,13	0,3	8,84

*) In accordance with ISO 5855-2. In the self-locking zone, the tolerances apply before forming out-of-round

4 Designation

EXAMPLE :

Description block Identity block

NUT EN4119 -050

Number of this standard _____

Thread code (see table 1) _____

iTeh STANDARD PREVIEW
(standards.iteh.ai)

NOTE: If necessary, the code I9005 shall be placed between the description block and the identity block.

<https://standards.iteh.ai/catalog/standards/sist/f8a5d293-264b-42d5-bbfd-5ae100745cfe/sist-en-4119-2004>

5 Marking

EN 2424, style A, as indicated on figure 1.

6 Technical specification

EN 3004