



SLOVENSKI STANDARD SIST EN 300 175-3 V1.8.1:2006

01-marec-2006

8 [[]HJbY]nVc`ýUbYVfYnj fj] bYhY_Y_ca i b]_UWYfB97HLÈ`G_i db]`j a Ygb]_`f7 ÷È
' "XY. `D`Ugh_fa]^b^UXcghcdUXc`dfYbcgbY[Ua YX]UfA57Ł

Digital Enhanced Cordless Telecommunications (DECT); Common Interface (CI); Part 3:
Medium Access Control (MAC) layer

iTeh STANDARD PREVIEW (standards.iteh.ai)

[SIST EN 300 175-3 V1.8.1:2006](https://standards.iteh.ai/catalog/standards/sist/c17df3fc-fe27-4739-b6d1-f4183b343d6a/sist-en-300-175-3-v1-8-1-2006)

[https://standards.iteh.ai/catalog/standards/sist/c17df3fc-fe27-4739-b6d1-](https://standards.iteh.ai/catalog/standards/sist/c17df3fc-fe27-4739-b6d1-f4183b343d6a/sist-en-300-175-3-v1-8-1-2006)

[f4183b343d6a/sist-en-300-175-3-v1-8-1-2006](https://standards.iteh.ai/catalog/standards/sist/c17df3fc-fe27-4739-b6d1-f4183b343d6a/sist-en-300-175-3-v1-8-1-2006)

Ta slovenski standard je istoveten z: **EN 300 175-3 Version 1.8.1**

ICS:

33.070.30 Öã äæ) ^/ã à[|zæ) ^ Digital Enhanced Cordless
à!^: ç|çã } ^/ã ^\ [{ ~ } ä æã Telecommunications (DECT)
ÖÖÓVD

SIST EN 300 175-3 V1.8.1:2006 en

iTeh STANDARD PREVIEW
(standards.iteh.ai)

SIST EN 300 175-3 V1.8.1:2006

<https://standards.iteh.ai/catalog/standards/sist/c17df3fc-fe27-4739-b6d1-f4183b343d6a/sist-en-300-175-3-v1-8-1-2006>

ETSI EN 300 175-3 V1.8.1 (2004-11)

European Standard (Telecommunications series)

Digital Enhanced Cordless Telecommunications (DECT); Common Interface (CI); Part 3: Medium Access Control (MAC) layer

iTeh STANDARD PREVIEW
(standards.iteh.ai)

[SIST EN 300 175-3 V1.8.1:2006](https://standards.iteh.ai/catalog/standards/sist/c17df3fc-fe27-4739-b6d1-f4183b343d6a/sist-en-300-175-3-v1-8-1-2006)

<https://standards.iteh.ai/catalog/standards/sist/c17df3fc-fe27-4739-b6d1-f4183b343d6a/sist-en-300-175-3-v1-8-1-2006>



Reference

REN/DECT-000215-3

Keywords

DECT, MAC, radio**ETSI**

650 Route des Lucioles
F-06921 Sophia Antipolis Cedex - FRANCE

Tel.: +33 4 92 94 42 00 Fax: +33 4 93 65 47 16

Siret N° 348 623 562 00017 - NAF 742 C
Association à but non lucratif enregistrée à la
Sous-Préfecture de Grasse (06) N° 7803/88

iTeh STANDARD PREVIEW
(standards.iteh.ai)

SIST EN 300 175-3 V1.8.1:2006

<https://standards.iteh.ai/catalog/standards/sist/c17df3fc-fe27-4739-b6d1-f4183b343d07/etsi-en-300-175-3-v1-8-1-2006>
Important notice

Individual copies of the present document can be downloaded from:

<http://www.etsi.org>

The present document may be made available in more than one electronic version or in print. In any case of existing or perceived difference in contents between such versions, the reference version is the Portable Document Format (PDF). In case of dispute, the reference shall be the printing on ETSI printers of the PDF version kept on a specific network drive within ETSI Secretariat.

Users of the present document should be aware that the document may be subject to revision or change of status. Information on the current status of this and other ETSI documents is available at

<http://portal.etsi.org/tb/status/status.asp>

If you find errors in the present document, please send your comment to one of the following services:

http://portal.etsi.org/chaicor/ETSI_support.asp

Copyright Notification

No part may be reproduced except as authorized by written permission.
The copyright and the foregoing restriction extend to reproduction in all media.

© European Telecommunications Standards Institute 2004.
All rights reserved.

DECT™, **PLUGTESTS™** and **UMTS™** are Trade Marks of ETSI registered for the benefit of its Members.
TIPHON™ and the **TIPHON logo** are Trade Marks currently being registered by ETSI for the benefit of its Members.
3GPP™ is a Trade Mark of ETSI registered for the benefit of its Members and of the 3GPP Organizational Partners.

Contents

Intellectual Property Rights	12
Foreword.....	12
1 Scope	13
2 References	13
3 Definitions, symbols and abbreviations	14
3.1 Definitions	14
3.2 Symbols.....	14
3.3 Abbreviations	14
4 Description of the MAC layer	16
4.1 MAC layer reference model	16
4.1.1 General.....	17
4.1.2 Cluster Control Function (CCF)	17
4.1.3 Cell Site Functions (CSF).....	17
4.1.4 Relationship to physical layer elements.....	17
4.2 Frame and multiframe structures.....	18
4.2.1 General.....	18
4.2.2 Frame structure	18
4.2.3 Multiframe structure	19
4.3 State definitions.....	20
4.3.1 PP states.....	20
4.3.2 RFP states	21
5 Overview of MAC layer services.....	22
5.1 General	22
5.1.1 Broadcast Message Control (BMC).....	22
5.1.2 Connectionless Message Control (CMC).....	22
5.1.3 Multi-Bearer Control	22
5.2 Service descriptions.....	22
5.2.1 Common functions.....	22
5.2.2 BMC service	23
5.2.3 CMC service	23
5.2.4 MBC services.....	23
5.3 Logical channels.....	24
5.3.1 MBC connection endpoints (MC-SAP logical channels)	24
5.3.1.1 The higher layer C-plane channels, C	24
5.3.1.2 The higher layer U-Plane channels, I	24
5.3.1.3 The higher layer U-Plane control channel, G _F	25
5.3.2 CMC endpoints (MB-SAP logical channels).....	25
5.3.2.1 The connectionless C-Plane channels, CL	25
5.3.2.2 The connectionless U-Plane channels, SI _N and SI _P	25
5.3.3 BMC endpoint (MA-SAP logical channel).....	25
5.3.3.1 The slow broadcast channel, B _S	25
5.3.4 Internal MAC control channels.....	26
5.3.4.1 The system information channel, Q	26
5.3.4.2 Identities channel, N.....	26
5.3.4.3 The MAC control channel, M	26
5.3.4.4 MAC paging channel, P	26
5.4 SAP definitions	26
5.4.1 MA SAP	27
5.4.2 MB SAP.....	27
5.4.3 MC SAP.....	27
5.4.4 ME SAP.....	28
5.4.5 Order of transmission.....	28
5.5 Bearers.....	28

5.5.1	Bearer types	28
5.5.2	Bearer operation.....	29
5.6	Connection oriented services.....	29
5.6.1	Connection types	29
5.6.1.1	Basic connections.....	29
5.6.1.2	Advanced connections	30
5.6.1.3	Connection identifiers	30
5.6.1.4	Complementary connections	30
5.6.2	Symmetric and asymmetric connections.....	30
5.6.2.1	Symmetric connections	31
5.6.2.2	Asymmetric connections	34
5.7	Broadcast and connectionless services	39
5.7.1	The broadcast services	40
5.7.1.1	The continuous broadcast service	40
5.7.1.2	The non-continuous broadcast service	40
5.7.2	The connectionless services	41
5.7.2.1	Connectionless downlink services	41
5.7.2.2	Connectionless uplink services	41
6	Multiplexing	42
6.1	CCF multiplexing functions	42
6.2	CSF multiplexing functions.....	42
6.2.1	Bit Mappings (MAP)	47
6.2.1.1	D-field mapping (D-MAP).....	47
6.2.1.1.1	D-field mapping for the double slot structure (physical packet P80)	48
6.2.1.1.2	D-field mapping for the full slot structure (physical packet P32).....	48
6.2.1.1.3	D-field mapping for the short slot structure (physical packet P00).....	49
6.2.1.1.4	D-field mapping for the half slot structure (physical packet P08j).....	49
6.2.1.2	A-field Mapping (A-MAP)	50
6.2.1.3	B-field Mapping (B-MAP)	51
6.2.1.3.1	Unprotected format.....	51
6.2.1.3.2	Encoded protected format.....	52
6.2.1.3.3	Multisubfield protected format.....	52
6.2.1.3.4	Singlesubfield protected format.....	54
6.2.2	Time multiplexers	54
6.2.2.1	Tail MULTipleXer (T-MUX)	55
6.2.2.1.1	T-MUX algorithm for RFP transmissions	55
6.2.2.1.2	T-MUX algorithm for PT transmissions.....	56
6.2.2.2	B-field control multiplexer (E/U-MUX)	57
6.2.2.3	B-field mode multiplexer (C-MUX)	58
6.2.2.3.1	Double slot full slot, D16 and D24 half slot modes.....	58
6.2.2.3.2	Half slot modes for 2-level modulation	70
6.2.3	Encryption.....	70
6.2.4	Scrambling	71
6.2.5	Error control.....	72
6.2.5.1	R-CRC overview	73
6.2.5.2	R-CRC generation and checking.....	73
6.2.5.3	X-CRC overview.....	74
6.2.5.4	X-CRC generation and checking.....	74
6.2.5.5	B-CRC generation and checking.....	76
6.2.6	Broadcast controller	77
7	Medium access layer messages	77
7.1	Header field	77
7.1.1	Overview/formatting.....	77
7.1.2	Tail identification, TA, bits a_0 to a_2	78
7.1.3	The "Q1/BCK" bit, bit a_3	78
7.1.4	B-field identification, BA, bits a_4 to a_6	78
7.1.5	The "Q2" bit, bit a_7	79
7.2	Messages in the tail field.....	79
7.2.1	Overview	79
7.2.2	Identities information (N_T).....	80

7.2.3	System information and multiframe marker (Q_T)	80
7.2.3.1	General	80
7.2.3.2	Static system information	81
7.2.3.2.1	General, $Q_H = 0, 1$ (hex)	81
7.2.3.2.2	Q_H and Normal-Reverse (NR)	81
7.2.3.2.3	Slot Number (SN)	82
7.2.3.2.4	Start Position (SP)	82
7.2.3.2.5	ESCAPE bit (ESC)	82
7.2.3.2.6	Number of transceivers	83
7.2.3.2.7	Extended RF carrier information available (M_c)	83
7.2.3.2.8	RF carriers available (RF-cars)	83
7.2.3.2.9	Spare bits (SPR)	83
7.2.3.2.10	Carrier number	84
7.2.3.2.11	Spare bits (SPR)	84
7.2.3.2.12	Primary receiver Scan Carrier Number (PSCN)	84
7.2.3.3	Extended RF carrier information part 1	85
7.2.3.3.1	General, $Q_H = 2$ (hex)	85
7.2.3.3.2	Further RF carrier extensions	85
7.2.3.3.3	Number of RF carriers	85
7.2.3.4	Fixed part capabilities	85
7.2.3.4.1	General, $Q_H = 3$ (hex)	85
7.2.3.4.2	Standard capabilities	86
7.2.3.5	Extended fixed part capabilities	87
7.2.3.5.1	General, $Q_H = 4$ (hex)	87
7.2.3.5.2	Extended Physical and MAC layer capabilities	87
7.2.3.5.3	Extended higher layer capabilities	88
7.2.3.6	Secondary access rights identities	88
7.2.3.6.1	General, $Q_H = 5$ (hex)	88
7.2.3.6.2	SARI message	88
7.2.3.7	Multiframe number	89
7.2.3.7.1	General, $Q_H = 6$ (hex)	89
7.2.3.7.2	Multiframe number	89
7.2.3.8	Escape	89
7.2.3.8.1	General, $Q_H = 7$ (hex)	89
7.2.3.8.2	Escape information	89
7.2.3.9	Extended RF carrier information part 2	89
7.2.3.9.1	General, $Q_H = 9$ (hex)	89
7.2.4	Paging Tail (P_T)	90
7.2.4.1	General format	90
7.2.4.1.1	P_T format for full and long page messages	90
7.2.4.1.2	P_T format for short page messages	90
7.2.4.1.3	P_T format for zero length page messages	90
7.2.4.1.4	P_T format for MAC_resume page message	90
7.2.4.2	P_T header format	90
7.2.4.2.1	General format	90
7.2.4.2.2	Bit a_8 is the extend flag	91
7.2.4.2.3	B_S SDU length indication	91
7.2.4.3	MAC layer information for PT	91
7.2.4.3.1	Information type	91
7.2.4.3.2	Fill bits	91
7.2.4.3.3	Blind full slot information	92
7.2.4.3.4	Bearer description	92
7.2.4.3.5	Escape	93
7.2.4.3.6	Dummy or connectionless downlink bearer marker	93
7.2.4.3.7	Bearer handover/replacement information	93
7.2.4.3.8	RFP status and modulation types	94
7.2.4.3.9	Active carriers	95
7.2.4.3.10	RFP power level	95
7.2.4.3.11	Blind double slot/RFP-FP interface resource information	96
7.2.4.3.12	Extended modulation types	96
7.2.5	MAC control (M_T)	97
7.2.5.1	General format and contents	97

7.2.5.2	Basic connection control	97
7.2.5.2.1	General	97
7.2.5.2.2	Format for most messages	98
7.2.5.2.3	WAIT	98
7.2.5.2.4	ATTRIBUTES_T_{Req;Cfm}	98
7.2.5.3	Advanced connection control	99
7.2.5.3.1	General	99
7.2.5.3.2	ACCESS_REQUEST	99
7.2.5.3.3	BEARER_HANDOVER_REQUEST	99
7.2.5.3.4	CONNECTION_HANDOVER_REQUEST	99
7.2.5.3.5	UNCONFIRMED_ACCESS_REQUEST	100
7.2.5.3.6	BEARER_CONFIRM	100
7.2.5.3.7	WAIT	100
7.2.5.3.8	ATTRIBUTES_T_{Req;Cfm}	100
7.2.5.3.9	BANDWIDTH_T_{Req;Cfm}	102
7.2.5.3.10	Channel_list	103
7.2.5.3.11	Unconfirmed_dummy	103
7.2.5.3.12	Unconfirmed_handover	104
7.2.5.3.13	RELEASE	104
7.2.5.4	MAC layer test messages	104
7.2.5.4.1	Basic format	104
7.2.5.4.2	FORCE_TRANSMIT	105
7.2.5.4.3	LOOPBACK_DATA	105
7.2.5.4.4	DEFEAT_ANTENNA_DIVERSITY	106
7.2.5.4.5	ESCAPE	107
7.2.5.4.6	NETWORK_TEST	107
7.2.5.4.7	CLEAR_TEST_MODES	107
7.2.5.4.8	CHANGE_MODULATION_SCHEME	107
7.2.5.5	Quality control	108
7.2.5.5.1	Prolonged preamble diversity	110
7.2.5.6	Broadcast and connectionless services	110
7.2.5.7	Encryption control	111
7.2.5.8	B-field setup, first PT transmission	112
7.2.5.9	Escape	112
7.2.5.10	TARI message	112
7.2.5.11	REP connection control	112
7.2.5.11.1	General	112
7.2.5.11.2	Format for most messages	112
7.2.5.11.3	REP CHANNEL MAP REQUEST	113
7.2.5.11.4	REP CHANNEL MAP CONFIRM	113
7.3	Messages in the B-field	113
7.3.1	Overview	113
7.3.2	Advanced connection control	114
7.3.2.1	General format	114
7.3.2.2	BEARER_REQUEST	115
7.3.2.3	BEARER_CONFIRM	115
7.3.2.4	WAIT	116
7.3.2.5	ATTRIBUTES_B_{Req;Cfm}	116
7.3.2.6	BANDWIDTH_B_{Req;Cfm}	117
7.3.2.7	CHANNEL_LIST	118
7.3.2.8	UNCONFIRMED_DUMMY	118
7.3.2.9	UNCONFIRMED_HANDOVER	118
7.3.2.10	RELEASE	118
7.3.3	Null	119
7.3.4	Quality control	120
7.3.4.1	General format	120
7.3.4.2	Bearer and connection control	120
7.3.4.3	RESET	122
7.3.4.4	Bearer quality in an asymmetric connection	122
7.3.5	Extended system information	123
7.3.5.1	General format	123
7.3.5.2	TARI messages	123

7.3.6	G _F channel data packet.....	123
7.3.7	Escape	124
8	Medium access layer primitives	124
8.1	Connection oriented service primitives	125
8.1.1	Connection setup: MAC_CON {req;ind;cfm}	125
8.1.2	Connection modification: MAC_MOD {req;ind;cfm}	126
8.1.3	CO data transmit ready: MAC_CO_DTR {ind}	127
8.1.4	CO data transfer: MAC_CO_DATA {req;ind}	128
8.1.5	Restart DLC: MAC_RES_DLC {ind}	128
8.1.6	Connection release: MAC_DIS {req;ind}	128
8.1.7	MAC bandwidth: MAC_BW {ind;res}	129
8.1.8	Encryption.....	129
8.1.8.1	Load encryption key: MAC_ENC_KEY {req}.....	129
8.1.8.2	Enable/disable encryption: MAC_ENC_EKS {req;ind;cfm}	129
8.1.9	C-plane switching procedure	130
8.1.9.1	C-plane switching procedure: MAC_C _S C _F {req, cfm, ind, res}	130
8.1.9.2	C-plane switching procedure: MAC_C _S C _F _END {ind}	130
8.2	Connectionless and broadcast service primitives	131
8.2.1	Paging: MAC_PAGE {req;ind}.....	131
8.2.2	Downlink connectionless: MAC_DOWN_CON {req;ind}	131
8.2.3	Uplink connectionless: MAC_UP_CON {req;ind;cfm}	132
8.3	Management primitives	132
8.3.1	Connection control.....	132
8.3.1.1	Connection setup: MAC_ME_CON {ind}.....	132
8.3.1.2	Connection setup allowed: MAC_ME_CON_ALL {req}	132
8.3.1.3	Bearer release: MAC_ME_REL {req}	132
8.3.1.4	MBC release report: MAC_ME_REL_REP {ind}	133
8.3.2	System information and identities	133
8.3.2.1	FP information preloading: MAC_ME_RFP_PRELOAD {req}	133
8.3.2.2	PT information preloading: MAC_ME_PT_PRELOAD {req}	133
8.3.2.3	System information output: MAC_ME_INFO {ind;res}	133
8.3.2.4	Extended system info: MAC_ME_EXT {req;ind;res;cfm}	133
8.3.3	Channel map: MAC_ME_CHANMAP {ind;res}	133
8.3.4	Status reports: MAC_ME_STATUS {req;ind;res;cfm}	134
8.3.5	Error reports: MAC_ME_ERROR {ind;res}	134
8.4	Flow control	134
8.4.1	MA SAP flow control.....	134
8.4.2	MB SAP flow control	134
8.4.3	MC SAP flow control	134
9	Broadcast and connectionless procedures	136
9.1	Downlink broadcast and connectionless procedures	136
9.1.1	Downlink broadcast procedure	136
9.1.1.1	Broadcast information.....	136
9.1.1.2	Channel selection for downlink broadcast services.....	137
9.1.1.3	Downlink broadcast procedure description	138
9.1.2	Downlink connectionless procedure	138
9.1.2.1	Channel selection at the RFP	138
9.1.2.2	Downlink connectionless procedure description.....	138
9.1.3	Paging broadcast procedure	139
9.1.3.1	RFP paging broadcasts.....	139
9.1.3.2	PP paging procedures.....	141
9.1.3.2.1	PP paging detection	141
9.1.3.2.2	PP paging processing.....	141
9.2	Uplink connectionless procedures	142
9.2.1	General.....	142
9.2.2	Bearer selection for the connectionless uplink.....	142
9.2.3	Procedure for the connectionless uplink	143
9.2.3.1	Predicates	143
9.2.3.2	PT D-field construction.....	143
9.2.3.3	PT transmission sequence	143

9.2.3.4	FT procedure	144
9.3	Non-continuous broadcast procedure	144
9.3.1	Request for specific Q channel information.....	144
9.3.1.1	A-field procedure	144
9.3.1.2	B-field procedure	145
9.3.2	Request for a new dummy bearer	145
10	Connection oriented service procedures.....	145
10.1	Overview	145
10.2	C/O connection setup	146
10.2.1	General.....	146
10.2.2	Initiation of a basic and a normal connection setup	146
10.2.3	Initiation of a fast connection setup	147
10.2.4	Connection setup procedure description	147
10.2.4.1	Creation of MBCs	147
10.2.4.2	Establishment of a single bearer duplex connection of a known service type	149
10.2.4.3	Establishment of multi-bearer connections and connections needing service negotiation.....	150
10.2.4.3.1	Symmetric connection	152
10.2.4.3.2	Asymmetric uplink connection.....	152
10.2.4.3.3	Asymmetric downlink connection.....	152
10.2.4.3.4	Connection established.....	153
10.3	C/O connection modification	153
10.3.1	Advanced connection: bandwidth modification.....	153
10.3.1.1	Suspend and resume	155
10.3.1.2	MAC resume paging	155
10.3.2	Advanced connection: service type or slot type modification	155
10.3.3	Connection type modification	157
10.3.4	Modulation type modification.....	159
10.3.4.1	Adaptive code rate.....	160
10.4	C/O connection release.....	160
10.4.1	General.....	160
10.4.2	Procedure description	161
10.5	C/O bearer setup	161
10.5.1	Single bearer setup procedures.....	161
10.5.1.1	Basic bearer setup procedure.....	162
10.5.1.2	A-field advanced single bearer setup procedure	164
10.5.1.2.1	PT initiated	164
10.5.1.2.2	FT initiated	167
10.5.1.3	B-field single bearer setup procedure.....	168
10.5.1.3.1	PT initiated	168
10.5.1.3.2	FT initiated	170
10.5.1.4	Double simplex setup procedure	171
10.5.1.5	Complementary connection bearer setup	174
10.5.1.6	Double duplex bearer setup procedure: Mapping procedure.....	175
10.5.2	Channel list procedures.....	176
10.5.2.1	Scope.....	176
10.5.2.2	Description of the channel list messages.....	177
10.5.2.3	Usage of the channel list messages	177
10.6	C/O bearer handover	178
10.6.1	General.....	178
10.6.2	Duplex bearer handover procedure.....	179
10.6.3	Double simplex bearer handover	179
10.6.4	Bearer replacement	180
10.6.4.1	General bearer replacement.....	180
10.6.4.2	Frequency replacement	180
10.7	C/O bearer release	181
10.7.1	General.....	181
10.7.2	Bearer release procedure description	182
10.7.2.1	Unacknowledged release procedure.....	182
10.7.2.2	Acknowledged release procedure.....	182
10.7.2.3	Fast release procedure	183
10.7.2.4	REP relayed bearer release.....	183

10.8	C/O data transfer	183
10.8.1	Higher layer associated signalling (C)	183
10.8.1.1	C _S channel data	184
10.8.1.1.1	Transmission principle	184
10.8.1.1.2	Numbering principle	184
10.8.1.2	C _F channel data	184
10.8.1.2.1	Transmission principle	184
10.8.1.2.2	Numbering principle	185
10.8.1.3	Q1 and Q2 bit settings for I _N and I _{P_error_detection} services	185
10.8.1.3.1	Q2 bit settings	186
10.8.1.3.2	Q1 bit settings	186
10.8.2	MOD-2 protected I channel operation (I _P)	187
10.8.2.1	General	187
10.8.2.2	Limiting the lifetime of packets	187
10.8.2.3	A-field shall always be correct	187
10.8.2.4	Use of the acknowledge bits	188
10.8.2.4.1	Q2 and ACK bit setting for I _{P_error_correction} services	188
10.8.2.4.2	BCK bit setting	188
10.8.2.5	Data jump procedures	189
10.8.2.5.1	Bearer replacement	189
10.8.2.5.2	Unilateral jump	189
10.8.2.5.3	MAC I _P bearer reset	191
10.8.3	Higher layer unprotected information (I _N) and MAC_error_detection services (I _P)	191
10.8.3.1	I _N minimum_delay service	191
10.8.3.2	I _N normal_delay and I _{P_error_detection} services	191
10.9	C/O procedures for FT connections with CRFP	192
10.9.1	Dual C/O bearer setup	192
10.9.2	C/O connection release of connection with CRFP	192
10.9.3	C/O connection suspend and resume	192
11	Medium access layer management procedures	193
11.1	Broadcasting	193
11.1.1	RFP transmission	193
11.1.2	PP reception	193
11.2	Extended system information	193
11.2.1	PP requests	193
11.2.2	RFP response	193
11.3	PP states and state transitions	193
11.3.1	Actions in Idle_Unlocked and Active_Unlocked states	193
11.3.2	Entry into the Idle_Locked state	193
11.3.3	Actions in the Idle_Locked state	194
11.3.3.1	Page detection in Idle_Locked state	194
11.3.3.2	Setup detection in Idle_Locked state	195
11.3.4	Idle_Locked and Active_Locked state transitions	195
11.4	Physical channel selection	195
11.4.1	The channel selection lists	195
11.4.2	Physical channel and RFP selection at the PP	197
11.4.3	Physical channel selection at the RFP	199
11.4.4	Hand over criteria due to in-connection base identification	200
11.4.5	Handover criteria due to interference	200
11.5	In-connection quality control	201
11.5.1	RFPI handshake	201
11.5.2	Frequency control	201
11.5.2.1	RFP measurement of frequency error	201
11.5.2.2	PT frequency correction	201
11.6	Maximum allowed system load at RFPs	201
11.7	PMID and FMID definitions	201
11.7.1	FMID definition	201
11.7.2	PMID definition	201
11.8	RFP idle receiver scan sequence	201
11.9	PT receiver scan sequence	202
11.10	Management of connections associated with Broadband data links	203

12	Medium access layer test message procedure	203
12.1	Introduction	203
12.2	General	204
12.2.1	Portable part testing	205
12.2.2	Fixed part testing	205
12.2.3	Applicability of test messages	205
12.3	FORCE_TRANSMIT	206
12.3.1	Portable part	206
12.3.2	Fixed part	207
12.4	LOOPBACK_DATA	207
12.4.1	Portable part	207
12.4.2	Fixed Part	207
12.4.2.1	IUTs implementing the DECT scrambler	207
12.4.2.2	IUTs implementing a proprietary scrambler	207
12.5	DEFEAT_ANTENNA_DIVERSITY	208
12.6	NETWORK_TEST	208
12.7	ESCAPE	208
12.8	CLEAR_TEST_MODES	208
12.9	CHANGE_MODULATION_SCHEME	208
Annex A (normative): MAC layer timers and constants		209
A.1	Timers and Time Windows	209
A.2	Constants	209
Annex B (informative): Construction of the CRC polynomial and error detecting performance		210
Annex C (informative): MAC relationship to other layers		211
Annex D (informative): Synchronization		212
Annex E (normative): Scrambling patterns		213
Annex F (informative): Seamless handover operation		214
F.1	I channel data flow for I _N _minimum_delay service	214
Annex G (normative): Requirements for PPs with direct PP to PP communication mode		215
G.1	Description of operation in direct PP to PP communication mode	215
G.2	Requirements	216
G.2.1	Setting the PP in direct communications mode	216
G.2.2	Specific Alternative 1 requirements	216
G.2.2.1	When the PP has not initiated a call	216
G.2.2.2	When the PP initiates a call	216
G.2.3	Specific Alternative 2 Requirements	217
Annex H (normative): Requirements for FPs with Wireless FT to FT (W-FT2FT) communication mode		218
H.1	Introduction	218
H.2	Description of operation in W-FT2FT communication mode	219
Annex I (normative): Channel coding and Modulation		220
I.1	Channel coding	220
I.1.1	The parallel Turbo Code Principle	221
I.1.2	The FOCTC implementation	221
I.1.2.1	The FOCTC concept	221
I.1.2.2	The FOCTC structure and the component code	222
I.1.2.3	The FOCTC Inner interleaving algorithm	224

I.1.2.4	FOOTC Inner interleaving size adaptation to all Physical Packet Formats	225
I.2	Adaptive coding and Modulation Embodiment.....	226
I.2.1	Adaptive code rates	227
I.2.1.1	Adaptive code rates for the double slot structure (physical packet P80)	228
I.2.1.2	Adaptive code rates for the full slot structure (physical packet P32).....	228
I.2.1.3	Adaptive code rates for the half slot structure (physical packet P08j).....	229
I.2.2	Puncturing patterns.....	230
I.2.3	Channel Capacity for the B-field map configurations	231
I.2.3.1	Double Slot Structure.....	231
I.2.3.2	Full Slot Structure.....	233
I.2.3.3	Half Slot Structure	234
I.3	Change Modulation Scheme	234
Annex J (informative):	Channel decoding.....	235
Annex K (informative):	Bibliography.....	236
Annex L (informative):	Change history	237
History		238

iTeh STANDARD PREVIEW (standards.iteh.ai)

[SIST EN 300 175-3 V1.8.1:2006](https://standards.iteh.ai/catalog/standards/sist/c17df3fc-fe27-4739-b6d1-f4183b343d6a/sist-en-300-175-3-v1-8-1-2006)

<https://standards.iteh.ai/catalog/standards/sist/c17df3fc-fe27-4739-b6d1-f4183b343d6a/sist-en-300-175-3-v1-8-1-2006>

Intellectual Property Rights

IPRs essential or potentially essential to the present document may have been declared to ETSI. The information pertaining to these essential IPRs, if any, is publicly available for **ETSI members and non-members**, and can be found in ETSI SR 000 314: "*Intellectual Property Rights (IPRs); Essential, or potentially Essential, IPRs notified to ETSI in respect of ETSI standards*", which is available from the ETSI Secretariat. Latest updates are available on the ETSI Web server (<http://webapp.etsi.org/IPR/home.asp>).

Pursuant to the ETSI IPR Policy, no investigation, including IPR searches, has been carried out by ETSI. No guarantee can be given as to the existence of other IPRs not referenced in ETSI SR 000 314 (or the updates on the ETSI Web server) which are, or may be, or may become, essential to the present document.

Foreword

This European Standard (Telecommunications series) has been produced by ETSI Project Digital Enhanced Cordless Telecommunications (DECT).

The present document is part 3 of a multi-part deliverable. Full details of the entire series can be found in part 1 [1].

Further details of the DECT system may be found in TR 101 178 and ETR 043 (see Bibliography).

National transposition dates	
Date of adoption of this EN:	12 November 2004
Date of latest announcement of this EN (doa):	28 February 2005
Date of latest publication of new National Standard or endorsement of this EN (dop/e):	31 August 2005
Date of withdrawal of any conflicting National Standard (dow):	31 August 2005

1 Scope

The present document gives an introduction and overview of the complete Digital Enhanced Cordless Telecommunications (DECT) Common Interface (CI).

The present document of the DECT CI specifies the Medium Access Control (MAC) layer. The MAC layer is part 3 of the DECT Common Interface standard and layer 2a of the DECT protocol stack.

It specifies three groups of MAC services:

- the broadcast message control service;
- the connectionless message control service; and
- the multi-bearer control service.

It also specifies the logical channels that are used by the above mentioned services, and how they are multiplexed and mapped into the Service Data Units (SDUs) that are exchanged with the Physical Layer (PHL).

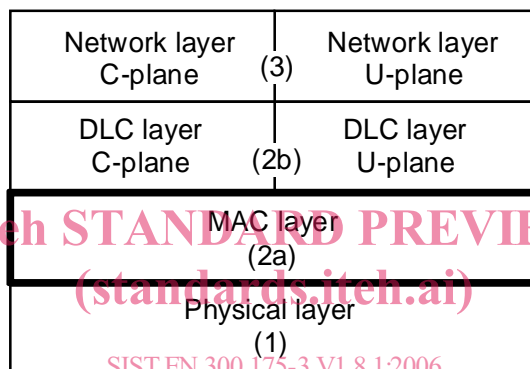

<https://standards.iteh.ai/catalog/standards/sist/c17df3fc-fe27-4739-b6d1-f41850543d6a/sist-en-300-175-3-v1-8-1-2006>
Figure 1: The DECT protocol stack

2 References

The following documents contain provisions which, through reference in this text, constitute provisions of the present document.

- References are either specific (identified by date of publication and/or edition number or version number) or non-specific.
- For a specific reference, subsequent revisions do not apply.
- For a non-specific reference, the latest version applies.

Referenced documents which are not found to be publicly available in the expected location might be found at <http://docbox.etsi.org/Reference>.

- [1] ETSI EN 300 175-1: "Digital Enhanced Cordless Telecommunications (DECT); Common Interface (CI); Part 1: Overview".
- [2] ETSI EN 300 175-2: "Digital Enhanced Cordless Telecommunications (DECT); Common Interface (CI); Part 2: Physical Layer (PHL)".
- [3] ETSI EN 300 175-4: "Digital Enhanced Cordless Telecommunications (DECT); Common Interface (CI); Part 4: Data Link Control (DLC) layer".
- [4] ETSI EN 300 175-5: "Digital Enhanced Cordless Telecommunications (DECT); Common Interface (CI); Part 5: Network (NWK) layer".