

INTERNATIONAL STANDARD

ISO
9818

First edition
1991-12-15

Passenger cars — Engine cooling systems — Test methods and marking of pressure caps

iTeh STANDARD PREVIEW
*Voitures particulières — Systèmes de refroidissement des moteurs —
Méthodes d'essai et marquage des soupapes de surpression/dépression*
(standards.iteh.ai)

ISO 9818:1991

<https://standards.iteh.ai/catalog/standards/sist/e07bf85a-cb15-4b33-b258-17a5a78c5c52/iso-9818-1991>



Reference number
ISO 9818:1991(E)

Foreword

ISO (the International Organization for Standardization) is a worldwide federation of national standards bodies (ISO member bodies). The work of preparing International Standards is normally carried out through ISO technical committees. Each member body interested in a subject for which a technical committee has been established has the right to be represented on that committee. International organizations, governmental and non-governmental, in liaison with ISO, also take part in the work. ISO collaborates closely with the International Electrotechnical Commission (IEC) on all matters of electrotechnical standardization.

Draft International Standards adopted by the technical committees are circulated to the member bodies for voting. Publication as an International Standard requires approval by at least 75% of the member bodies casting a vote.

International Standard ISO 9818 was prepared by Technical Committee ISO/TC 22, *Road vehicles*, Sub-Committee SC 24, *Interchangeability of components of passenger cars*.

ISO 9818 forms one of a series, consisting of the following International Standards:

ISO 9133:1988, *Passenger cars — Engine cooling systems — Threaded pressure caps and their seats on filler necks*.

ISO 9817:1991, *Passenger cars — Engine cooling systems — Dimensions of pressure caps and their ramp seats on filler necks*.

ISO 9818:1991, *Passenger cars — Engine cooling systems — Test methods and marking of pressure caps*.

Annex A forms an integral part of this International Standard.

© ISO 1991

All rights reserved. No part of this publication may be reproduced or utilized in any form or by any means, electronic or mechanical, including photocopying and microfilm, without permission in writing from the publisher.

International Organization for Standardization
Case Postale 56 • CH-1211 Genève 20 • Switzerland

Printed in Switzerland

Passenger cars — Engine cooling systems — Test methods and marking of pressure caps

1 Scope

This International Standard specifies test methods and a marking system for pressure caps for use in engine cooling systems of passenger cars.

2 Test method

For the test given in 2.1 and for residual pressure measurement as described in 2.2, the standard filler seat with clamping ramps as described in annex A shall be used.

2.1 Valve opening test under pressure and depression

This test shall be carried out at room temperature.

The valve opening pressure shall be the pressure for which a constant leak rate of 30 cm³/min is obtained.

A microleak of 100 cm³/h is permitted before the valve opens itself.

2.2 Residual pressure for seats with clamping ramps

The residual pressure shall be measured at room temperature.

The pressure inside the filler neck shall be measured after pressure stabilization, with the cap pawls in position in the ramp decompression notch (dimension l_6).

2.3 Endurance tests

2.3.1 Fitting and removing caps from seat

This test consists in the cap being fitted on, and removed from, the filler neck x times at room temperature.

The number of such operations shall be defined by common agreement between the cap manufacturer and the user.

2.3.2 Endurance test under alternate pressure

Cycles of alternate pressure, consisting of a succession of injections of pressurized air into a test liquid composed mainly of 50 % ethylene glycol solution, shall be applied to the cap according to figure 1.

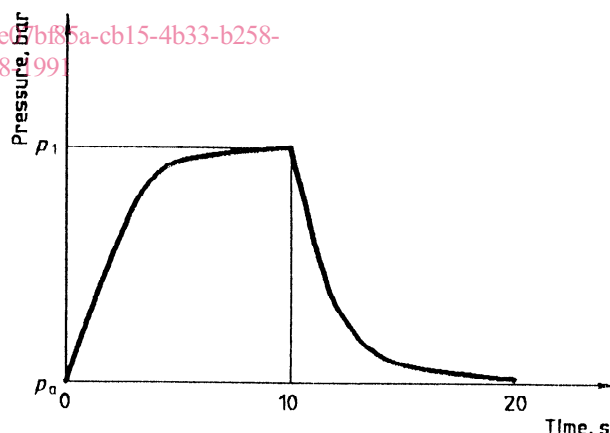

p_0 : atmospheric pressure
 p_1 : 120 % of the opening pressure

NOTE — The shape of the curve is given for information only.

Figure 1

The test liquid temperature, defined by agreement between the cap manufacturer and the user, shall be equal to or greater than 80 °C.

The pressure valve seal shall be in contact with the test liquid.

2.3.3 Endurance test under alternate depression

Cycles of alternate pressure, consisting of a succession of injections of pressurized air into a test liquid composed mainly of 50 % ethylene glycol solution, shall be applied to the cap according to figure 2.

The test liquid temperature, defined by agreement with the cap manufacturer and the user, shall be equal to or greater than 80 °C.

The depression valve shall be in contact with the test liquid.

3 Marking

The cap shall be marked on the outside with

- a) the nominal pressure, in kilopascals;
- b) a danger warning, either stated in full letters or represented by the symbol \triangle .

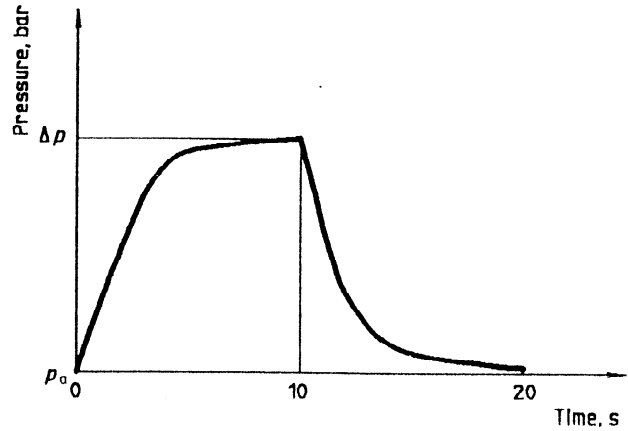

p_a : atmospheric pressure

$\Delta p = p_n - p$: 120 % of the valve opening depression

p : valve opening depression

NOTE — The shape of the curve is given for information only.

Figure 2

iTeh STANDARD PREVIEW
(standards.iteh.ai)

ISO 9818:1991

<https://standards.iteh.ai/catalog/standards/sist/e07bf85a-cb15-4b33-b258-17a5a78c5c52/iso-9818-1991>

Annex A
(normative)

Standard seat with clamping ramp

A.1 Dimensions and shape

See figure A.1 and table A.1.

Dimensions in millimetres

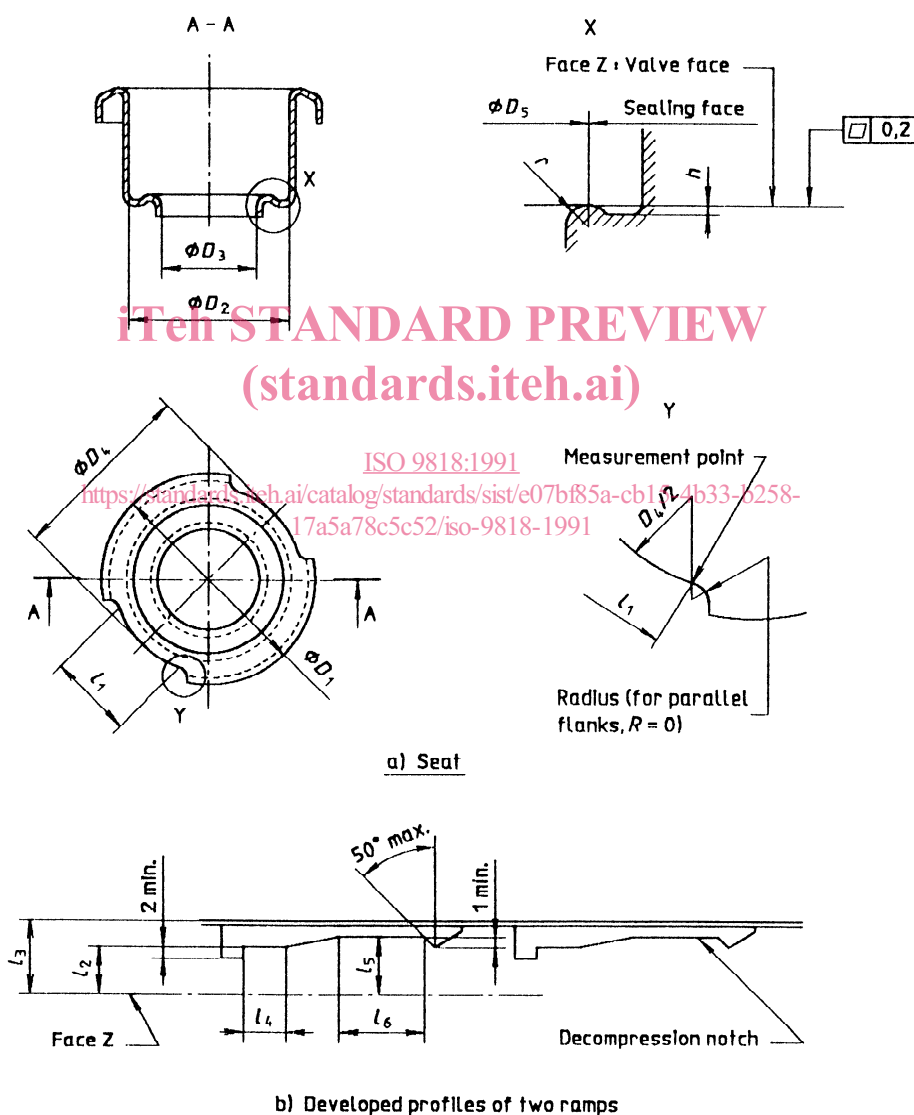

Figure A.1 — Seat with clamping ramps

Table A.1 — Dimensions

Dimensions in millimetres

D_1 $\pm 0,5$	D_2	D_3 ¹⁾ min.	D_4 max.	D_5 $\pm 0,02$	h ¹⁾ min.	l_1	l_2 $\pm 0,02$	l_3 $\pm 0,02$	l_4 min.	l_5 ¹⁾ $\begin{matrix} +0,02 \\ 0 \end{matrix}$	l_6 ¹⁾ min.	r ¹⁾
43	$31,4 \pm 0,3$	19,4	39	22,8	0,3	12	10,6	15,8	11,5	12,2	11,5	1,5 to 2
56,5	$41,5 \pm 0,5$	27,3	49,5	31,5	0,3	23	13,9	19,5	13	16	23	1,5 to 2

1) Recommended values.

A.2 Material

The standard seat with clamping ramp shall be made of steel with a hard chromium plating.

iTeh STANDARD PREVIEW
(standards.iteh.ai)

ISO 9818:1991

<https://standards.iteh.ai/catalog/standards/sist/e07bf85a-cb15-4b33-b258-17a5a78c5c52/iso-9818-1991>

iTeh STANDARD PREVIEW
(standards.iteh.ai)

This page intentionally left blank

[ISO 9818:1991](#)

<https://standards.iteh.ai/catalog/standards/sist/e07bf85a-cb15-4b33-b258-17a5a78c5c52/iso-9818-1991>

iTeh STANDARD PREVIEW
(standards.iteh.ai)

ISO 9818:1991

<https://standards.iteh.ai/catalog/standards/sist/e07bf85a-cb15-4b33-b258-17a5a78c5c52/iso-9818-1991>

UDC 629.113:621.43-71:683.533

Descriptors: road vehicles, private cars, internal combustion engines, cooling systems, filling devices, stoppers, tests, pressure tests, fatigue tests, marking.

Price based on 4 pages
