



Designation: C 472 – 99

# Standard Test Methods for Physical Testing of Gypsum, Gypsum Plasters and Gypsum Concrete<sup>1</sup>

This standard is issued under the fixed designation C 472; the number immediately following the designation indicates the year of original adoption or, in the case of revision, the year of last revision. A number in parentheses indicates the year of last reapproval. A superscript epsilon ( $\epsilon$ ) indicates an editorial change since the last revision or reapproval.

*This standard has been approved for use by agencies of the Department of Defense.*

## 1. Scope

1.1 These test methods cover the physical testing of gypsum, gypsum plasters, and gypsum concrete.

1.2 The test methods appear in the following sections:

	Sections
Precautions for Physical Tests	4
Reagents and Materials	5
Free Water	6
Fineness	7
Normal Consistency of Gypsum Plaster	8
Normal Consistency of Gypsum Concrete	9
Setting Time	10
Setting Time (Temperature Rise Method)	11
Compressive Strength	12
Density	13

1.3 The values regarded as the standard are either in inch-pound units or SI (metric). The values stated first shall be regarded as the standard. Values following in parentheses are approximate and are provided for information purposes only.

1.4 The text of this standard references notes and footnotes which provide explanatory material. These notes and footnotes (excluding those in tables and figures) are not requirements of the standard.

1.5 *This standard does not purport to address all of the safety concerns, if any, associated with its use. It is the responsibility of the user of this standard to establish appropriate safety and health practices and determine the applicability of regulatory limitations prior to use.* For a specific precautionary statement, see X1.2.1.

## 2. Referenced Documents

### 2.1 ASTM Standards:

C 11 Terminology Relating to Gypsum and Related Building Materials and Systems<sup>2</sup>

C 778 Specification for Standard Sand<sup>2</sup>

<sup>1</sup> These test methods are under the jurisdiction of ASTM Committee C-11 on Gypsum and Related Building Materials and Systems and are the direct responsibility of Subcommittee C11.01 on Specifications and Test Methods for Gypsum Products.

Current edition approved May 10, 1999. Published June 1999. Originally published as C 472-61. Last previous edition C 472-98.

<sup>2</sup> *Annual Book of ASTM Standards*, Vol 04.01.

E 11 Specification for Wire-Cloth Sieves for Testing Purposes<sup>3</sup>

## 3. Terminology

### 3.1 Definitions:

3.1.1 For useful definitions refer to Terminology C 11.

## 4. Precautions for Physical Tests

4.1 Gypsum products are greatly affected by small amounts of impurities introduced by careless laboratory manipulation. In order to obtain accurate results, it is absolutely essential to observe the following precautions:

4.1.1 Keep all apparatus thoroughly clean. Remove all traces of set plaster.

NOTE 1—For mixing pastes and mortars, a 500-ml rubber dental bowl is a convenience.

NOTE 2—Use care when drying gypsum, gypsum plasters, or gypsum concrete. Exceeding the specified drying temperatures may calcine the specimens, which will cause inaccurate test results.

## 5. Reagents and Materials

5.1 *Distilled or Deionized Water*—free of chlorides and sulfates at a temperature of  $21 \pm 1^\circ\text{C}$  ( $70 \pm 2^\circ\text{F}$ ).

5.2 *Standard Sand*— Specification C 778, 20–30 sand.

## 6. Free Water

6.1 *Significance and Use*—This test method determines the free water contained in gypsum, gypsum plasters, and gypsum concrete samples, and prepares the sample for subsequent testing.

### 6.2 Apparatus:

6.2.1 *Balance*, capable of weighing not less than 500 g at a precision of 0.1 g.

6.2.2 *Drying Oven*, set at  $45 \pm 3^\circ\text{C}$ .

6.2.3 *Desiccator*, containing calcium chloride or equivalent desiccant.

### 6.3 Procedure:

6.3.1 Weigh a sample of not less than 500 g of the material as received to the nearest 0.1 g and spread it to a thin layer in

<sup>3</sup> *Annual Book of ASTM Standards*, Vol 14.02.

a suitable vessel. Place in an oven (6.2.2) and dry for 2 h; then cool in a desiccator (6.2.3) and weigh again.

6.3.2 Retain the dried sample in an airtight container until used for the fineness test (Section 7).

6.4 *Report*—Report the loss in weight as a percentage of the original weight of the sample as received to a precision of 0.1%.

6.5 *Precision and Bias*—The precision and bias of the free water test method have not been determined.

## 7. Fineness

7.1 *Significance and Use*—This test method covers a procedure for determining the fineness of gypsum and gypsum plasters and is used to determine compliance with gypsum and gypsum plaster specifications. The degree of correlation between the results of this test method and service performance has not been determined.

### 7.2 Apparatus:

7.2.1 *Sieves*, as required by a particular gypsum or gypsum plaster specification, in accordance with Specification E 11.

7.2.2 *Balance*, capable of weighing not less than 1000 g at a precision of 0.1 g.

### 7.2.3 Mechanical Sieving Machine

### 7.3 Procedure:

7.3.1 Determine fineness by sieving a known weight of the dried sample through sieves of the specified sizes (Note 3 and Note 4). The size of the sample to be used in determining fineness depends upon the particle size of the material. If the material will pass a 6.3-mm (1/4-in.) sieve, a 100-g sample will be sufficient; if the largest particles are more than 25 mm (1 in.) in diameter, use not less than a 1000-g sample. With these limitations the size of sample to be used is left to the discretion of the operator. Shake the sample through each sieve with as little abrasion as possible (Note 5). Weigh the amount of material retained on each sieve and calculate the fineness, expressed as a percentage of the weight of the original sample.

7.3.2 If a mechanical sieving machine is used, make a series of tests at one minute intervals, with each type of material and sieve size combination to be used. When not more than 0.5 g passes each sieve in a one minute interval, use that time as the standard sieving time for that test procedure on that machine.

NOTE 3—For suggested method of sieving gypsum through a 45- $\mu$ m (No. 325) sieve, see Appendix X1.

NOTE 4—The sizes of the sieves to be used are given in the specifications of ASTM covering the particular product in question.

NOTE 5—When sieving by hand through a 150- $\mu$ m (No. 100) sieve, use a lateral motion, and tap the side of the sieve with the palm of the hand. Continue without brushing until not more than 0.5 g passes through during 1 min of sieving. If the sieve openings become clogged, transfer the retained material temporarily to another vessel, invert the sieve over a sheet of paper on the table and tap it sharply against the table. Then transfer all the retained material back into the sieve and continue sieving.

7.4 *Report*—Report the percent by weight retained on each sieve or passing particular sieves in accordance with the material specification to the nearest full percentage point.

7.5 *Precision and Bias*—The precision and bias of the fineness test method have not been determined.

## 8. Normal Consistency of Gypsum Plaster

8.1 *Significance and Use*—This test method is used to determine the volume of water required for mixing gypsum plaster when performing the setting time and compressive strength tests.

### 8.2 Apparatus:

8.2.1 *Modified Vicat Apparatus*—The modified Vicat apparatus (Fig. 1)<sup>4</sup> shall consist of a bracket, A, bearing a movable brass rod, B, 6.3 mm in diameter and of suitable length to fit the Vicat Bracket. A conical plunger made of aluminum with an apex angle of 53° 08 min and a height of 45 mm shall be attached to the lower end of the rod. The total weight of the rod and plunger shall be 35 g. A means shall be provided for adding a weight, G, to the rod, increasing the total weight to 50 g. The rod shall be capable of being held in any position by a screw, E. The rod shall have a mark, D, midway between the ends which moves under a scale, F, graduated in millimetres, attached to the bracket, A.

8.2.2 *Mold*—The conical ring mold shall be made of a noncorroding, nonabsorbent material, and shall have an inside diameter of 60 mm at the base and 70 mm at the top and a height of 40 mm.

<sup>4</sup> This method is described by Kuntze, R. A., "An Improved Method for the Normal Consistency of Gypsum Plasters," *ASTM Bulletin No. 246*, ASTM, May 1960, p. 35.

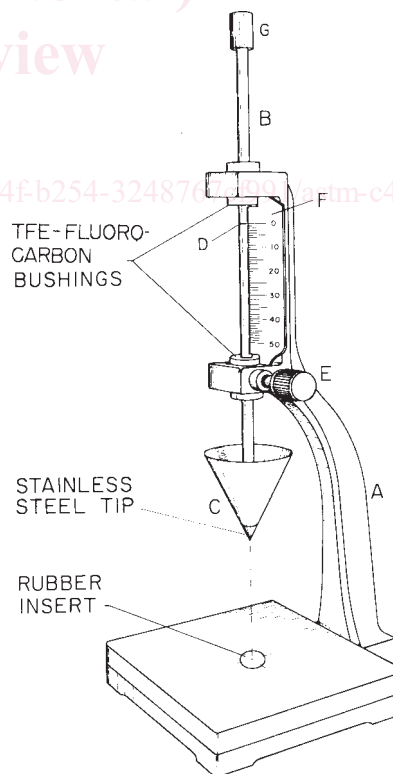

A—Hinged support bracket  
 B—Plunger support rod  
 C—Conical plunger  
 D—Graduation mark  
 E—Lock screw  
 F—Modified scale  
 G—Weight

FIG. 1 Modified Vicat Apparatus (Conical Plunger Method)

8.2.3 *Base Plate*—The base plate for supporting the ring mold shall be of plate glass and about 100 mm square.

8.2.4 *Balance*, capable of weighing not less than 500 g at a precision of 0.1 g.

8.2.5 *Graduated Cylinder*, shall be made to deliver the indicated volume at 20°C (68°F) and shall be subdivided to not less than 1 mL.

8.3 *Procedure:*

8.3.1 Clean the plunger, mold, and base plate of the modified Vicat apparatus. Apply a thin coat of petroleum jelly or other suitable lubricant to the upper surface of the base plate in order to prevent leaks during the test.

8.3.2 Sift a weighed quantity of the sample (200 to 300 g as required to fill the mold) into a known volume of water (See 5.1). If the plaster is unretarded, add to the mixing water 0.2 g of sodium citrate per 100 g of sample. After allowing the sample to soak for 2 min, stir the mixture for 1 min to an even fluidity. Pour this sample into the ring mold, work slightly to remove air bubbles, and then strike off flush with the top of the mold. Wet the plunger of the modified Vicat apparatus and lower it to the surface of the sample at approximately the center of the mold. Read the scale and release the plunger immediately. After the rod has settled, read the scale again. Make three determinations on each mix, care being taken to have the mold completely filled and the plunger clean and wet.

8.3.3 Test gypsum molding plaster and gypsum gauging plaster with different amounts of water until a penetration of  $30 \pm 2$  mm is obtained. Use the rod and plunger for this determination weighing 35 g.

8.3.4 Test all gypsum mixtures containing aggregates with different amounts of water until a penetration of  $20 \pm 2$  mm is obtained. Add weight to the rod and plunger to bring the total weight to 50 g for these determinations.

8.3.5 Mix gypsum neat plaster with standard sand (see 5.2) in the ratio of 200 g of sand to 100 g of plaster before testing for normal consistency.

8.4 *Report:*

Report the normal consistency as the average number of milliliters of water required to be added to 100 g of the dry mixture to the nearest whole milliliter.

8.5 *Precision and Bias*—The precision and bias of the test method for normal consistency of gypsum plaster have not been determined.

9. Normal Consistency of Gypsum Concrete

9.1 *Significance and Use*—This test method is used to determine the volume of water required for mixing gypsum concrete when performing the setting time and compressive strength tests.

9.2 *Apparatus:*

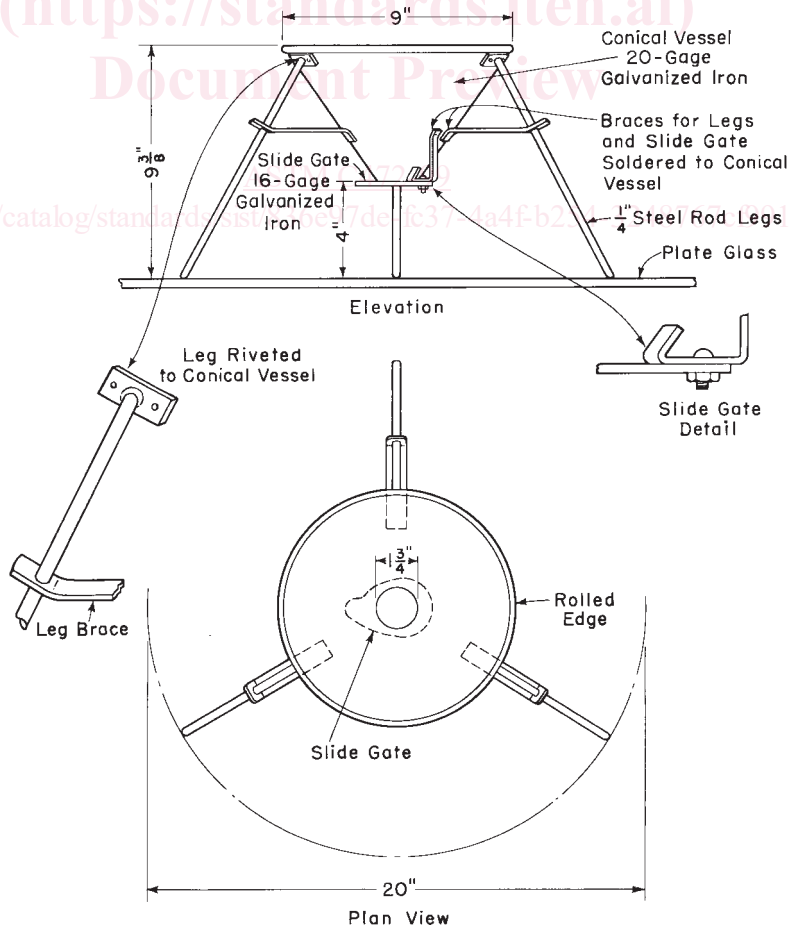

FIG. 2 Consistometer

9.2.1 *Consistometer* (Fig. 2)—The consistometer consists of a conical vessel made of noncorroding, nonabsorbent material, and having an inside diameter of 9 in. (229 mm) at the top and 1¾ in. (44.5 mm) at the bottom, and a height of 5½ in. (139.7 mm). It shall be provided with a sliding gate at the bottom and supported so that the bottom is 4 in. (102 mm) above the base plate. The base plate shall be of plate glass, free of scratches and about 18 in. (457 mm) square.

9.2.2 *Balance*, capable of weighing not less than 2000 g at a precision of 1 g.

9.3 *Procedure:*

9.3.1 Clean and dry the consistometer and the base plate and close the sliding gate.

9.3.2 Sift 2000 g of the sample into a known volume of water (see 5.1) to which 1.0 g of sodium citrate has previously been added. After allowing the sample to soak for 1 min, stir the mixture for 3 min to an even fluidity. Pour the mixture into the consistometer until level with the top. Then rapidly and completely open the sliding gate, allowing the mixture to run out onto the base plate. When the sliding gate is opened, take care to avoid jarring the consistometer.

9.3.3 Measure the resulting patty along its major and minor axes and determine the average diameter.

9.3.4 Test gypsum concrete with different amounts of water until a patty diameter of 380 ± 13 mm (15 ± ½ in.) is obtained.

9.4 *Report*—Report the normal consistency as the number of milliliters of water to the nearest whole milliliter required to be added to 100 g of the gypsum concrete.

9.5 *Precision and Bias*—The precision and bias of the test method for normal consistency of gypsum concrete have not been determined.

10. *Setting Time*

10.1 *Significance and Use*—This test method is used to determine the setting time of gypsum plaster and gypsum concrete, and is used to determine compliance with gypsum plaster and gypsum concrete specifications. Since variable job conditions influence the setting time, the degree of correlation between this test method and service performance has not been determined.

10.1.1 This test method does not determine the time of complete hydration of gypsum plaster or gypsum concrete. To determine the time of complete hydration see *Setting Time, (Temperature Rise Method,)* Section 11.

10.2 *Apparatus:*

10.2.1 *Vicat Apparatus*—The Vicat apparatus (Fig. 3) shall consist of a frame, *A*, bearing a movable rod, *B*, weighing 300 g, one end, *C*, the plunger end, being 10 mm in diameter for a distance of not less than 50 mm, the other end having a removable needle, *D*, 1 mm in diameter and 50 mm in length. The rod, *B*, shall be reversible, shall be able to be held in any position by a screw, *E*, and shall have an adjustable indicator, *F*, that moves over a scale (graduated in millimeters) attached to the frame, *A*. The paste shall be held in a rigid conical ring, *G*, resting on a glass plate, *H*, about 100 mm square. The ring shall be made of a noncorroding, nonabsorbent material and shall have an inside diameter of 70 mm at the base and 60 mm at the top, and a height of 40 mm.

10.2.2 In addition, the Vicat apparatus shall conform to the following requirements:

Weight of plunger	300 ± 0.5 g
Diameter of larger end of plunger	10 ± 0.05 mm

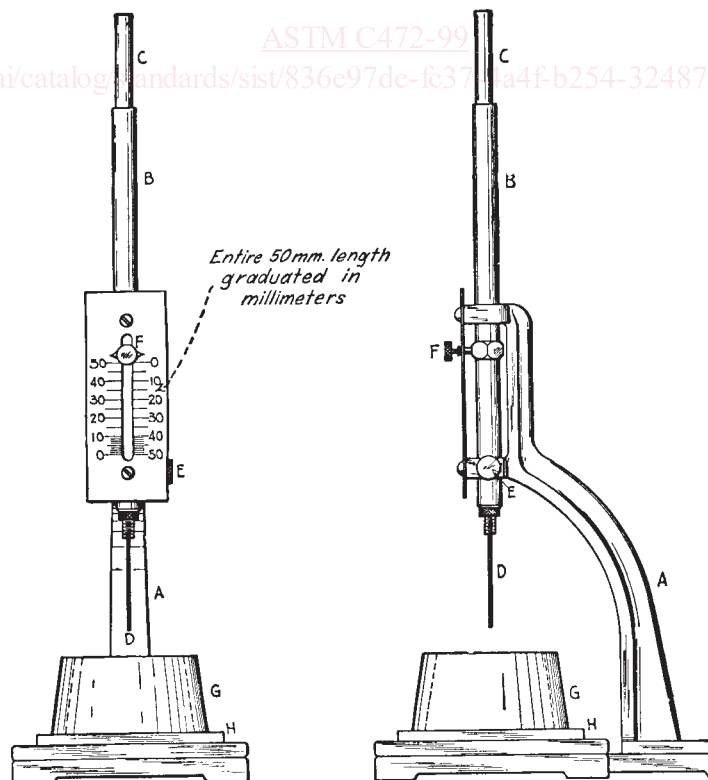

FIG. 3 Vicat Apparatus