



**SLOVENSKI STANDARD**  
**SIST ISO 9838:1995**

**01-december-1995**

---

**Varnostne vezi za alpske smuči - Testni vložek za preskušanje varnostnih vezi**

Alpine ski-bindings -- Test soles for ski-binding tests

Fixations de skis alpins -- Semelles d'essai pour les essais de fixations de skis

**Ta slovenski standard je istoveten z: ISO 9838:1991**

[SIST ISO 9838:1995](https://standards.iteh.ai/catalog/standards/sist/c7ede579-1458-4371-8d5c-9fc2fafea2d4/sist-iso-9838-1995)

<https://standards.iteh.ai/catalog/standards/sist/c7ede579-1458-4371-8d5c-9fc2fafea2d4/sist-iso-9838-1995>

**ICS:**

97.220.20      Oprema za zimske športe      Winter sports equipment

**SIST ISO 9838:1995**

**en**

**iTeh STANDARD PREVIEW**  
**(standards.iteh.ai)**

[SIST ISO 9838:1995](#)

<https://standards.iteh.ai/catalog/standards/sist/c7ede579-1458-4371-8d5c-9fc2fafa2d4/sist-iso-9838-1995>

# INTERNATIONAL STANDARD

**ISO**  
**9838**

First edition  
1991-07-15

---

---

## Alpine ski-bindings — Test soles for ski-binding tests

**iTeh STANDARD PREVIEW**  
*Fixations de skis alpins — Semelles d'essai pour les essais de fixations de skis*  
**(standards.iteh.ai)**

[SIST ISO 9838:1995](#)

<https://standards.iteh.ai/catalog/standards/sist/c7ede579-1458-4371-8d5c-9fc2fafea2d4/sist-iso-9838-1995>



Reference number  
ISO 9838:1991(E)

## Foreword

ISO (the International Organization for Standardization) is a worldwide federation of national standards bodies (ISO member bodies). The work of preparing International Standards is normally carried out through ISO technical committees. Each member body interested in a subject for which a technical committee has been established has the right to be represented on that committee. International organizations, governmental and non-governmental, in liaison with ISO, also take part in the work. ISO collaborates closely with the International Electrotechnical Commission (IEC) on all matters of electrotechnical standardization.

Draft International Standards adopted by the technical committees are circulated to the member bodies for voting. Publication as an International Standard requires approval by at least 75 % of the member bodies casting a vote.

International Standard ISO 9838 was prepared by Technical Committee ISO/TC 83, *Sports and recreational equipment*.

[SIST ISO 9838:1995](https://standards.iteh.ai/catalog/standards/sist/c7ede579-1458-4371-8d5c-9fc2fafa2d4/sist-iso-9838-1995)

<https://standards.iteh.ai/catalog/standards/sist/c7ede579-1458-4371-8d5c-9fc2fafa2d4/sist-iso-9838-1995>

## Alpine ski-bindings — Test soles for ski-binding tests

### 1 Scope

This International Standard defines a test sole representing a ski-boot, or at least the bottom part of it, to be used for testing alpine ski-bindings for alpine skiing in accordance with ISO 9462 and ISO 9465.

NOTE 1 Ski-boots have their own International Standard (ISO 5355), which allows relatively large tolerances in defining the test sole which are generally believed to be suitable for on-slope use by skiers but too large for reproducible laboratory measurements.

### 2 Normative references

The following standards contain provisions which, through reference in this text, constitute provisions of this International Standard. At the time of publication, the editions indicated were valid. All standards are subject to revision, and parties to agreements based on this International Standard are encouraged to investigate the possibility of applying the most recent editions of the standards indicated below. Members of IEC and ISO maintain registers of currently valid International Standards.

ISO 868:1985, *Plastics and ebonite — Determination of indentation hardness by means of a durometer (Shore hardness)*.

ISO 5355:1991, *Alpine ski-boots — Safety requirements and test methods*.

ISO 9462:1988, *Alpine ski-bindings — Safety requirements and test methods*.

ISO 9465:—<sup>1)</sup>, *Alpine ski-bindings — Lateral toe release under impact loading — Safety requirements and test method*.

1) To be published.

### 3 Definitions

For the purposes of this International Standard, the definitions given in ISO 5355 and the following definitions apply.

**3.1 test sole type A:** A test sole for adults in accordance with ISO 5355, type A, suitable for bindings of type A and C in accordance with ISO 9462

**3.2 test sole type C:** A test sole for children in accordance with ISO 5355, type C, suitable for bindings of type C in accordance with ISO 9462.

**3.3 basic test sole:** A one-piece sole of length 305 mm for type A and 255 mm for type C.

**3.4 variable length soles:** A sole that is either adjustable, in two parts, or a set of several fixed length soles — between 270 mm and 360 mm for type A and between 200 mm and 280 mm for type C.

### 4 Material and manufacture

The sole shall be moulded in polyurethane, reinforced by a metal insert in order to achieve the mechanical requirements in clause 6. It is moulded in a homogeneous material and in a mould with the same roughness on the sole/binding interface to ensure that the friction coefficient is the same all over this interface.

In the shell areas, reinforcement is allowed to support the walls. It should remain outside the flat area.

### 5 Dimensions

The dimensions of the basic sole shall be as shown in figure 1 and figure 2. Except for the overall length, all the dimensions also apply to the variable length soles subject to the tolerances in table 1.

## 6 Mechanical properties

### 6.1 Flexional stiffness

Place the test sole (basic or variable) on two supports as shown in figure 3. The radius of the supports shall be  $10 \text{ mm} \pm 1 \text{ mm}$  and the test sole shall be supported over its whole width. Load the test sole vertically during 10 s at its middle by means of a contact ram with a radius of 10 mm, and record the deflection under load. Record the residual deflection 20 s after releasing. Test at  $23 \text{ °C} \pm 5 \text{ °C}$ . The load  $F_1$  shall be:

- type A:  $F_1 = 400 \text{ N}$
- type C:  $F_1 = 200 \text{ N}$

### 6.2 Compressional stiffness

Place the test sole in a device of aluminium or steel as shown in figure 4. Compress the test sole during 10 s along its length axis and record the deformation under load. Record the residual deformation 20 s after releasing. Test at  $23 \text{ °C} \pm 5 \text{ °C}$ . The load  $F_2$  shall be:

- type A:  $F_2 = 500 \text{ N}$
- type C:  $F_2 = 250 \text{ N}$

### 6.3 Hardness

A measurement of the Shore-D hardness shall be carried out on the sole/binding interface according to ISO 868. Test at  $23 \text{ °C} \pm 5 \text{ °C}$ .

### 6.4 Coefficient of friction

A measurement of the coefficient of friction shall be carried out in accordance with ISO 5355.

### 6.5 Coefficient of thermal expansion

The difference in length of the test sole at temperatures of  $23 \text{ °C}$  and  $-20 \text{ °C}$  respectively shall be measured.

### 6.6 Requirements

The requirements for the properties given in 6.1 to 6.5 shall be as indicated in table 2.

## 7 Long-term use

A test sole can be used for tests in accordance with ISO 9462 as long as it meets the requirements of this International Standard. Compliance shall be rechecked regularly, particularly with respect to

-- dimensions (wear of the contact area with bindings);

-- friction (presence of binding lubricants, scratches, etc.).

Table 1 — Tolerances

Dimensions in millimetres

Dimension	Tolerance for nominal dimension of				
	0,5 to 3	> 3 to 6	> 6 to 30	> 30 to 120	> 120 to 315
Length dimensions	$\pm 0,15$	$\pm 0,2$	$\pm 0,5$	$\pm 0,8$	$\pm 1,2$
Radius and chamfer	$\pm 0,2$	$\pm 0,5$	$\pm 1$	$\pm 2$	—

Dimensions in millimetres

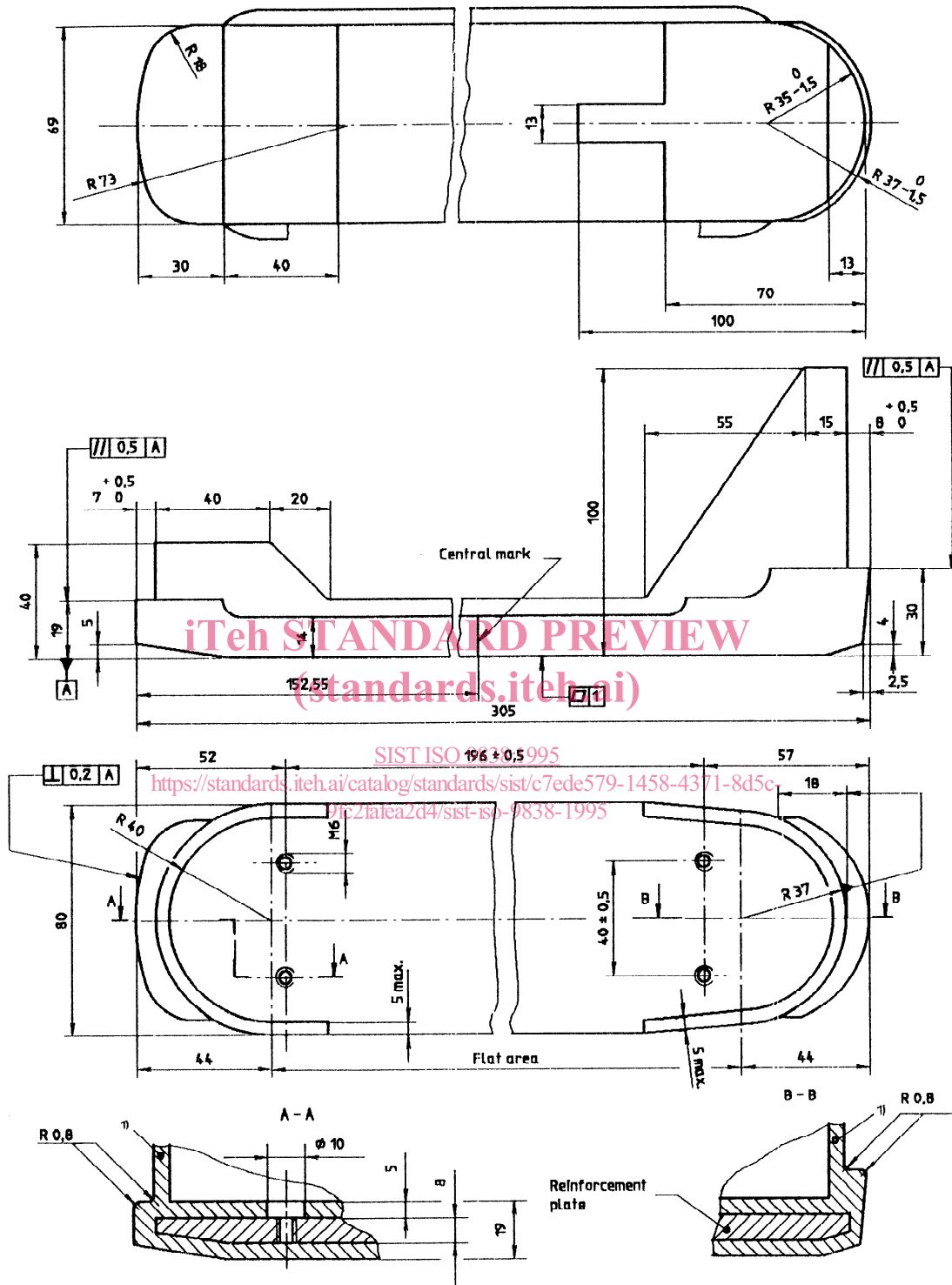

1) See clause 4.

Figure 1 — Test sole type A

Dimensions in millimetres

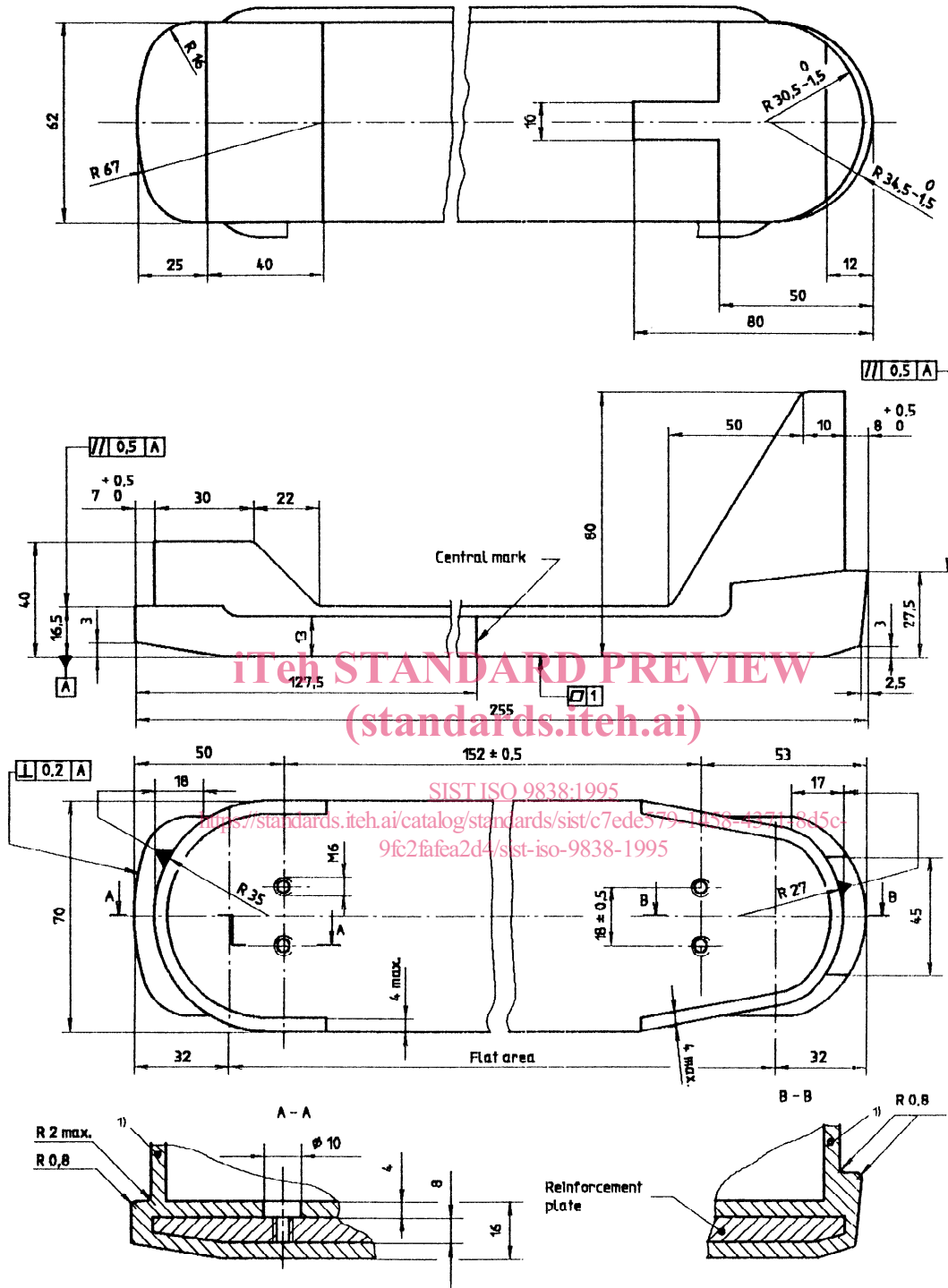

1) See clause 4.

Figure 2 — Test sole type C