

5 YfcbUj h\_U! Gcfb] žbcfa UbUXj UbU'gfcVU[ `Uj Užý]fc\_U'fc`YfUbWŁXc`[ `bUj c`ž  
]n`Y[ ]fUbY[ U`Y`UždfYj`Y Yb]`g`\_UXa ]Ya `!`?`Ug]Z\_UWU`.%\$\$\$`ADU'fbf]`hYa dYfUi f]  
c\_c`]WŁXc` ) `š7

Aerospace series - Bolts, normal bi-hexagonal head, coarse tolerance normal shank, long thread, in alloy steel, cadmium plated - Classification: 1100 MPa (at ambient temperature)/235 °C

Luft- und Raumfahrt - Zwölfkantschrauben, langes Gewinde, aus legiertem Stahl, verkadmet - Klasse: 1100 MPa (bei Raumtemperatur)/235 °C

Série aérospatiale - Vis à tête bihexagonale normale, tige normale à tolérance large, filetage long, en acier allié, cadmiées - Classification: 1100 MPa (à température ambiante)/235 °C

**Ta slovenski standard je istoveten z: EN 4136:2009**

**ICS:**

49.030.30 Matice Nuts

**SIST EN 4136:2009 en,de**

**iTeh STANDARD PREVIEW**  
**(standards.iteh.ai)**

SIST EN 4136:2009

<https://standards.iteh.ai/catalog/standards/sist/6bcdaa78-aed8-4e77-a040-51c11ebe6dde/sist-en-4136-2009>

EUROPEAN STANDARD  
NORME EUROPÉENNE  
EUROPÄISCHE NORM

**EN 4136**

July 2009

ICS 49.030.30

English Version

**Aerospace series - Bolts, normal bi-hexagonal head, coarse tolerance normal shank, long thread, in alloy steel, cadmium plated - Classification: 1 100 MPa (at ambient temperature) / 235 °C**

Série aérospatiale - Vis à tête bihexagonale normale, tige normale à tolérance large, filetage long, en acier allié, cadmiées - Classification: 1 100 MPa (à température ambiante) / 235 °C

Luft- und Raumfahrt - Zwölfkantschrauben, langes Gewinde, aus legiertem Stahl, verkadmet - Klasse: 1 100 MPa (bei Raumtemperatur) / 235 °C

This European Standard was approved by CEN on 6 June 2009.

CEN members are bound to comply with the CEN/CENELEC Internal Regulations which stipulate the conditions for giving this European Standard the status of a national standard without any alteration. Up-to-date lists and bibliographical references concerning such national standards may be obtained on application to the CEN Management Centre or to any CEN member.

This European Standard exists in three official versions (English, French, German). A version in any other language made by translation under the responsibility of a CEN member into its own language and notified to the CEN Management Centre has the same status as the official versions.

[SIST EN 4136:2009](https://standards.iteh.ai/catalog/standards/sist/6bcdaa78-aed8-4e77-a040-f7a1b1e1d2e4/european-standard-EN-4136-2009)

CEN members are the national standards bodies of Austria, Belgium, Bulgaria, Cyprus, Czech Republic, Denmark, Estonia, Finland, France, Germany, Greece, Hungary, Iceland, Ireland, Italy, Latvia, Lithuania, Luxembourg, Malta, Netherlands, Norway, Poland, Portugal, Romania, Slovakia, Slovenia, Spain, Sweden, Switzerland and United Kingdom.



EUROPEAN COMMITTEE FOR STANDARDIZATION  
COMITÉ EUROPÉEN DE NORMALISATION  
EUROPÄISCHES KOMITEE FÜR NORMUNG

**Management Centre: Avenue Marnix 17, B-1000 Brussels**

**Contents**

Page

Foreword.....	3
1 Scope .....	4
2 Normative references .....	4
3 Required characteristics.....	5
4 Designation .....	7
5 Marking .....	7
6 Technical specification .....	7

**iTeh STANDARD PREVIEW**  
**(standards.iteh.ai)**

[SIST EN 4136:2009](https://standards.iteh.ai/catalog/standards/sist/6bcdaa78-aed8-4e77-a040-51c11ebe6dde/sist-en-4136-2009)

<https://standards.iteh.ai/catalog/standards/sist/6bcdaa78-aed8-4e77-a040-51c11ebe6dde/sist-en-4136-2009>

## Foreword

This document (EN 4136:2009) has been prepared by the Aerospace and Defence Industries Association of Europe - Standardization (ASD-STAN).

After enquiries and votes carried out in accordance with the rules of this Association, this Standard has received the approval of the National Associations and the Official Services of the member countries of ASD, prior to its presentation to CEN.

This European Standard shall be given the status of a national standard, either by publication of an identical text or by endorsement, at the latest by January 2010, and conflicting national standards shall be withdrawn at the latest by January 2010.

Attention is drawn to the possibility that some of the elements of this document may be the subject of patent rights. CEN [and/or CENELEC] shall not be held responsible for identifying any or all such patent rights.

According to the CEN/CENELEC Internal Regulations, the national standards organizations of the following countries are bound to implement this European Standard: Austria, Belgium, Bulgaria, Cyprus, Czech Republic, Denmark, Estonia, Finland, France, Germany, Greece, Hungary, Iceland, Ireland, Italy, Latvia, Lithuania, Luxembourg, Malta, Netherlands, Norway, Poland, Portugal, Romania, Slovakia, Slovenia, Spain, Sweden, Switzerland and the United Kingdom.

**ITEH STANDARD PREVIEW**  
**(standards.iteh.ai)**

[SIST EN 4136:2009](https://standards.iteh.ai/catalog/standards/sist/6bcdaa78-aed8-4e77-a040-51c11ebe6dde/sist-en-4136-2009)

<https://standards.iteh.ai/catalog/standards/sist/6bcdaa78-aed8-4e77-a040-51c11ebe6dde/sist-en-4136-2009>

**EN 4136:2009 (E)****1 Scope**

This standard specifies the characteristics of bolts, normal bi-hexagonal head, coarse tolerance normal shank, long thread, in alloy steel, cadmium plated.

Classification: 1 100 MPa <sup>1)</sup> / 235 °C <sup>2)</sup>

**2 Normative references**

The following referenced documents are indispensable for the application of this document. For dated references, only the edition cited applies. For undated references, the latest edition of the referenced document (including any amendments) applies.

EN 2133, *Aerospace series — Cadmium plating of steels with specified tensile strength  $\leq 1\,450$  MPa, copper, copper alloys and nickel alloys.*

EN 2137, *Steel FE-PL75 —  $1\,100\text{ MPa} \leq R_m \leq 1\,250\text{ MPa}$  — Bars  $D_e \leq 100\text{ mm}$  — Aerospace series.* <sup>3)</sup>

EN 2424, *Aerospace series — Marking of aerospace products.*

EN 2442 <sup>4)</sup>, *Steel FE-PL711 —  $1\,100\text{ MPa} \leq R_m \leq 1\,300\text{ MPa}$  — Bars and wires  $D_e \leq 25\text{ mm}$  — Aerospace series.* <sup>3)</sup>

EN 3514, *Aerospace series — Steel FE-PL711 — Hardened and tempered —  $1\,100 \leq R_m \leq 1\,300\text{ MPa}$  — Bar and wire for bolts —  $D_e \leq 25\text{ mm}$ .* <sup>5)</sup>

EN 9100, *Aerospace series — Quality management systems — Requirements (based on ISO 9001:2000) and Quality systems — Model for quality assurance in design, development, production, installation and servicing (based on ISO 9001:1994).*

EN 9133, *Aerospace series — Quality management systems — Qualification procedure for aerospace standard parts.*

ISO 3203, *Aerospace — Bolts, normal bihexagonal head, normal or pitch diameter shank, long length MJ threads, metallic material, coated or uncoated, strength classes less than or equal to 1 100 MPa — Dimensions.*

ISO 3353-1, *Aerospace — Lead and runout threads — Part 1: Rolled external threads.*

ISO 4095, *Aerospace — Bihexagonal drives — Wrenching configuration — Metric series.*

ISO 5855-2, *Aerospace — MJ threads — Part 2: Limit dimensions for bolts and nuts.*

ISO 7689, *Aerospace — Bolts, with MJ threads, made of alloy steel, strength class 1 100 MPa — Procurement specification.*

ISO 7913, *Aerospace — Bolts and screws, metric — Tolerances of form and position.*

TR 3775, *Aerospace series — Bolts and pins — Materials.* <sup>6)</sup>

---

1) Minimum tensile strength of the material at ambient temperature.

2) Maximum temperature that the bolt can withstand without continuous change in its original characteristics, after return to ambient temperature. The maximum temperature is determined by the surface treatment

3) Published as ASD Standard at the date of publication of this standard.

4) Inactive for new designation, see prEN 3514.

5) Published as ASD Prestandard at the date of publication of this standard.

6) Published as ASD Technical Report at the date of publication of this standard.

### 3 Required characteristics

#### 3.1 Configuration — Dimensions — Masses

See Figure 1 and Table 1.

Dimensions and tolerances are: in conformity with ISO 3203, expressed in millimetres and apply after surface treatment.

#### 3.2 Tolerances of form and position

ISO 7913

#### 3.3 Materials

EN 2137, EN 2442

or

TR 3775 (alloy steel, classification 1 100 MPa)

#### 3.4 Surface treatment

EN 2133, 8  $\mu\text{m}$  to 14  $\mu\text{m}$  on all surfaces which can be contacted by a 20 mm diameter ball. On all other surfaces, a continuous cadmium plating shall be present, but no value is specified.

Black colour option: code B



Values in micrometres apply prior to surface treatment.

<https://standards.iteh.ai/catalog/standards/sist/6bcdaa78-aed8-4e77-a040-51c11e6e6dde/sist-en-4136-2009>

Break sharp edges 0,1 to 0,4.

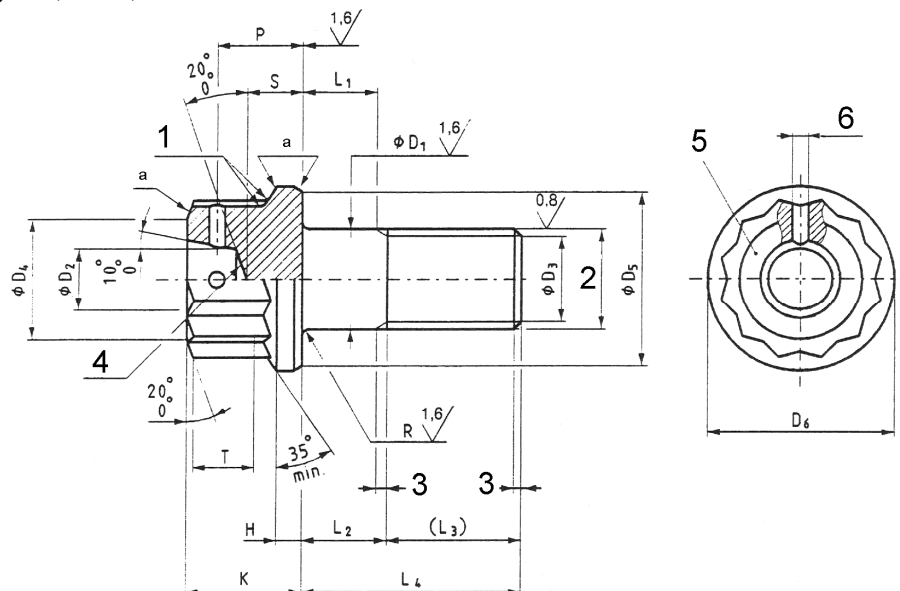

#### Key

- |   |                                    |   |  |
|---|------------------------------------|---|--|
| 1 | Radius 0,3 min                     | 4 | Shape optional                                 |
| 2 | Thread                             | 5 | Marking  |
| 3 | Conforms to ISO 3353-1             | 6 | 4 holes $\varnothing D_7$ equidistant optional |
| a | Rounded or chamfered in this area. |   |  |

Figure 1

Table 1

Diameter code	Thread <sup>a</sup>	$D_1$	$D_2$	$D_3$	$D_4$	$D_5$	$D_6$	$D_7$	$H$	$K$	$L_1$ <sup>b, c, d</sup>	$L_2$ <sup>b, c, d</sup>
		h12	$\begin{matrix} 0 \\ -0,5 \end{matrix}$	$\pm 0,5$	min.	min.	max.	H13	min.	h15	min.	max.
050	MJ5×0,8 - 4h6h	5	3,2	3,4	6,8	8,3	9,1	1	1	6,5	0,5	4
060	MJ6×1 - 4h6h	6	4,1	4,2	7,8	9,8	10,6	1,4	1,2	7,5	0,7	
070	MJ7×1 - 4h6h	7	4,9	5,2	8,8	11,3	12,1		1,4	8,2		
080	MJ8×1 - 4h6h	8	5,2	6,2	9,8	12,8	13,6		1,6	8,6		
100	MJ10×1,25 - 4h6h	10	6,7	7,9	11,8	15,7	16,7	1,6	2	10,1	0,8	6
120	MJ12×1,25 - 4h6h	12	8	9,8	13,7	18,8	19,9		2,4	11,4	0,9	

Diameter code	$L_3$	$L_4 \pm 0,3$ <sup>d, e</sup>		$P$	$R$		$S$	$T$	Wrenching dash number <sup>f</sup>	Mass <sup>g</sup>	
	Length code	nom.		nom.	Tol.	$\begin{matrix} +0,4 \\ 0 \end{matrix}$	min.	h		i	
050	16	020 to 070	20 to 70	4,5	0,5		2,5	2,8	7	4,410	0,306
060	18	022 to 084	22 to 84	5,2			2,8	3,5	8	6,655	0,444
070	20	024 to 098	24 to 98	5,9	0,7	$\begin{matrix} 0 \\ -0,2 \end{matrix}$	3,3	3,8	9	9,716	0,604
080	22	026 to 112	26 to 112	6,3			3,7	3,9	10	13,956	0,790
100	26	032 to 140	32 to 140	7,7	0,8		4,7	4,2	12	25,653	1,232
120	30	036 to 168	36 to 168	8,8	0,9	$\begin{matrix} 0 \\ -0,3 \end{matrix}$	5,6	4,5	14	42,337	1,774

<sup>a</sup> In accordance with ISO 5855-2.

<sup>b</sup> First length corresponding to first  $L_4$  length.

<sup>c</sup> Condition  $L_1$  min. and  $L_2$  max. cannot be obtained simultaneously.

<sup>d</sup> Increments:

- 2 for  $L_4 \leq 100$ ;
- 4 for  $L_4 > 100$ .

<sup>e</sup> If greater lengths are required, they shall be chosen using the above increments. The length code corresponds to the length  $L_4$ , completed by one or two zeros to the left, where necessary, to obtain a three digit code.

<sup>f</sup> In accordance with ISO 4095 over  $T$  min.

<sup>g</sup> Approximate values (kg/1 000 pieces), calculated on the basis of 7,85 kg/dm<sup>3</sup>, given for information purposes only. They apply to bolts without holes.

<sup>h</sup> value for head and first  $L_4$ .

<sup>i</sup> Increase for each additional 2 mm of  $L_4$ .