Aerospace series - Pipe coupling 8-30' in titanium alloy - Elbows 90o welded end

Aerospace series - Pipe coupling 8°30' in titanium alloy - Elbows 90° welded end

Luft- und Raumfahrt - Rohrverschraubung 8°30' aus Titanlegierung -
Winkelverschraubungen 90° mit Anschweißende

Série aérospatiale - Systeme de raccordement 8°30' en alliage de titane - Raccords
coudés a 90° a souder

STANDARD PREVIEW
(standards.iteh.ai)

Ta slovenski standard je istoveten z: **EN 4019:2001**

SIST EN 4019:2002
<https://standards.iteh.ai/catalog/standards/sist/c59d40c6-25ba-41b1-9ac7-b7db7cfd44e/sist-en-4019-2002>

ICS:

49.080

Ščē\āēĀ•[|b\ā
@ā!æ|ā}āāc{āēĀ^|ā

Aerospace fluid systems and
components

SIST EN 4019:2002

en

iTeh STANDARD PREVIEW
(standards.iteh.ai)

SIST EN 4019:2002

<https://standards.iteh.ai/catalog/standards/sist/c39d40e6-25ba-41b1-9ac7-b7db7cff4f4e/sist-en-4019-2002>

iTeh STANDARD PREVIEW
(standards.iteh.ai)

SIST EN 4019:2002

<https://standards.iteh.ai/catalog/standards/sist/c39d40e6-25ba-41b1-9ac7-b7db7cfd4e/sist-en-4019-2002>

iTeh STANDARD PREVIEW
(standards.iteh.ai)

SIST EN 4019:2002

<https://standards.iteh.ai/catalog/standards/sist/c39d40e6-25ba-41b1-9ac7-b7db7cfd4e/sist-en-4019-2002>

iTeh STANDARD PREVIEW
(standards.iteh.ai)

SIST EN 4019:2002

<https://standards.iteh.ai/catalog/standards/sist/c39d40e6-25ba-41b1-9ac7-b7db7cfd4e/sist-en-4019-2002>

iTeh STANDARD PREVIEW (standards.iteh.ai)

SIST EN 4019:2002

<https://standards.iteh.ai/catalog/standards/sist/c39d40e6-25ba-41b1-9ac7-b7db7cfd4f4e/sist-en-4019-2002>

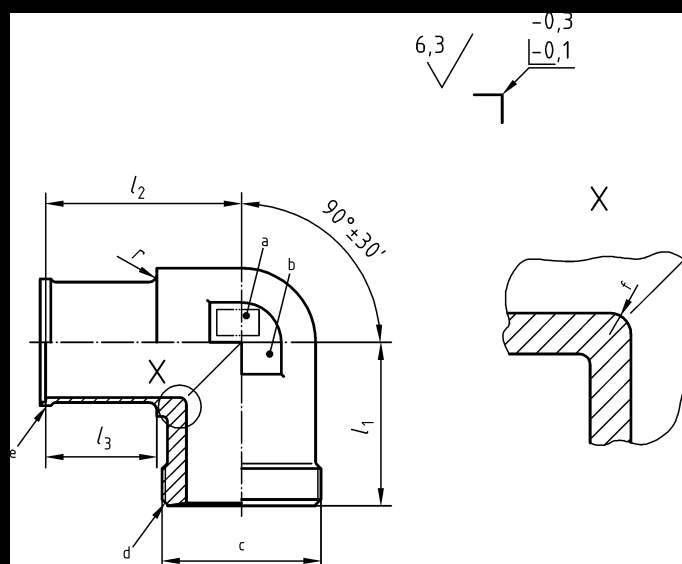

iTeh STANDARD PREVIEW
(standards.iteh.ai)

SIST EN 4019:2002

<https://standards.iteh.ai/catalog/standards/sist/c39d40e6-25ba-41b1-9ac7-b7db7cfd4e/sist-en-4019-2002>

Description block	Identity block
ELBOW 90°	<u>EN4019-0806</u>
Number of this standard	_____
Code (see table 1)	_____

iTeh STANDARD PREVIEW
(standards.iteh.ai)

SIST EN 4019:2002

<https://standards.iteh.ai/catalog/standards/sist/c39d40e6-25ba-41b1-9ac7-b7db7cfd4e/sist-en-4019-2002>