

INTERNATIONAL STANDARD

ISO
9866-2

First edition
1991-09-15

Textiles — Effect of dry heat on fabrics under low pressure —

Part 2:

**Determination of dimensional change in fabrics
exposed to dry heat**

iTeh STANDARD PREVIEW
(standards.iteh.ai)

<https://standards.iteh.ai/catalog/standards/sist/6156d14e-82c1-4045-b163-6c5dd00621d0/iso-9866-2-1991>
*Textiles — Effet de la chaleur sèche sur des tissus sous basse
pression*

*Partie 2: Détermination de la variation des dimensions de tissus exposés
à la chaleur sèche*



Reference number
ISO 9866-2:1991(E)

Foreword

ISO (the International Organization for Standardization) is a worldwide federation of national standards bodies (ISO member bodies). The work of preparing International Standards is normally carried out through ISO technical committees. Each member body interested in a subject for which a technical committee has been established has the right to be represented on that committee. International organizations, governmental and non-governmental, in liaison with ISO, also take part in the work. ISO collaborates closely with the International Electrotechnical Commission (IEC) on all matters of electrotechnical standardization.

Draft International Standards adopted by the technical committees are circulated to the member bodies for voting. Publication as an International Standard requires approval by at least 75 % of the member bodies casting a vote.

International Standard ISO 9866-2 was prepared by Technical Committee ISO/TC 38, *Textiles*, Sub-Committee SC 2, *Cleansing, finishing and water resistance tests*.

ISO 9866 consists of the following parts, under the general title *Textiles — Effect of dry heat on fabrics under low pressure*:

- *Part 1: Procedure for dry-heat treatment of fabrics*
- *Part 2: Determination of dimensional change in fabrics exposed to dry heat*

Textiles — Effect of dry heat on fabrics under low pressure —

Part 2:

Determination of dimensional change in fabrics exposed to dry heat

1 Scope

This part of ISO 9866 specifies a method for determining the dimensional change of fabrics on exposure to dry heat. It is intended to predict the behaviour of fabrics in garment-making processes such as fusing and transfer printing.

2 Normative references

The following standards contain provisions which, through reference in this text, constitute provisions of this part of ISO 9866. At the time of publication, the editions indicated were valid. All standards are subject to revision, and parties to agreements based on this part of ISO 9866 are encouraged to investigate the possibility of applying the most recent editions of the standards indicated below. Members of IEC and ISO maintain registers of currently valid International Standards.

ISO 139:1973, *Textiles — Standard atmospheres for conditioning and testing*.

ISO 3759:1984, *Textiles — Preparation, marking and measuring of fabric specimens and garments in tests for determination of dimensional change*.

ISO 9866-1:1991, *Textiles — Effect of dry heat on fabrics under low pressure — Part 1: Procedure for dry-heat treatment of fabrics*.

3 Principle

Specimens of fabric are heated under specified conditions in accordance with the method described

in ISO 9866-1, and the changes in specimen dimensions are measured.

4 Apparatus

4.1 Press, as described in ISO 9866-1. It is essential that the working area of the test press is larger than the specimen size.

4.2 Rule, not less than 750 mm in length, preferably with an engraved, bevelled edge, marked in millimetres, for measuring fabric specimens.

4.3 Flexible steel rule or fibre-glass tape, marked in millimetres, for measuring garments.

4.4 Means of marking reference points, for example:

4.4.1 Indelible ink.

4.4.2 Fine threads, of colour contrasting with the fabric.

4.4.3 Heated wire, with which small holes may be made (for thermoplastics fabrics only).

4.4.4 Staples, with measurements made from the point of entry of the staple into the fabric. Indicate on the fabric which end of the staple is used for measurement.

4.5 Flat table, of dimensions such that the complete article being tested can be laid flat for measurement.

4.6 Means of producing the standard atmosphere for conditioning and testing textiles, as specified in clause 5.

5 Atmospheres for conditioning and testing

Unless otherwise indicated, the following atmospheres, as specified in ISO 139, shall be used:

- a) for pre-conditioning, an atmosphere having a relative humidity of 10 % or lower and temperature of 50 °C or lower;
- b) for conditioning and testing, an atmosphere having a relative humidity of (65 ± 2) % and a temperature of (20 ± 2) °C or (27 ± 2) °C.

6 Test specimens

Prepare test specimens as described in ISO 3759, except that the dimensions and distance between reference points shall be as follows:

Cut two uncreased specimens with edges parallel to the length and width of the fabric. Overall specimen dimensions shall be 240 mm in the weft or course direction and 290 mm in the warp or wale direction (see figure 1).

Do not take specimens directly from the ends of the material since experience has shown that the mass per unit area (or structure) and the finishing may be different to that of the majority of the fabric.

7 Procedure

7.1 Determine the dimensions AB, CD, EF and GH (see figure 1) of a preconditioned [see clause 5 a)] specimen to the nearest 0,5 mm.

7.2 Expose the specimen to dry heat as described in ISO 9866-1. Unless otherwise specified, use the following test conditions:

- temperature: 150 °C
- pressure: 0,3 kPa
- time: 20 s

It is essential that the working area of the test press is larger than the specimen size.

7.3 If required, measure the dimensions AB, CD, EF and GH of the specimen to the nearest 0,5 mm as soon as the specimen has cooled.

7.4 Condition the specimen in its flat state in the standard atmosphere [see clause 5 b)] for 4 h or until equilibrium is reached.

7.5 Measure the dimensions AB, CD, EF, GH of the specimen to the nearest 0,5 mm.

7.6 Repeat the procedure with the second specimen.

8 Expression of results

8.1 Calculate, for each specimen, the changes in dimensions, expressed as a percentage of the original dimension, for each test length using the formula

$$\frac{l_1 - l_0}{l_0} \times 100$$

where

l_0 is the original dimension, measured on the preconditioned specimen;

l_1 is the same dimension measured after the dry-heat treatment, cooling and conditioning.

8.2 For each specimen, calculate the mean dimensional change in each direction; if required, this is done for the intermediate state (see 7.3) as well as for the final, conditioned, state (see 7.5).

9 Test report

The test report shall include the following information:

- a) the number and year of publication of this International Standard, i.e. ISO 9866-1:1991;
- b) all details necessary for the identification of the sample tested;
- c) any deviation from the test conditions specified;
- d) the mean dimensional change in each direction for each specimen, expressed as in clause 8;
- e) if required, the mean dimensional change for the intermediate state;
- f) any appearance changes that occur.

Dimensions in millimetres

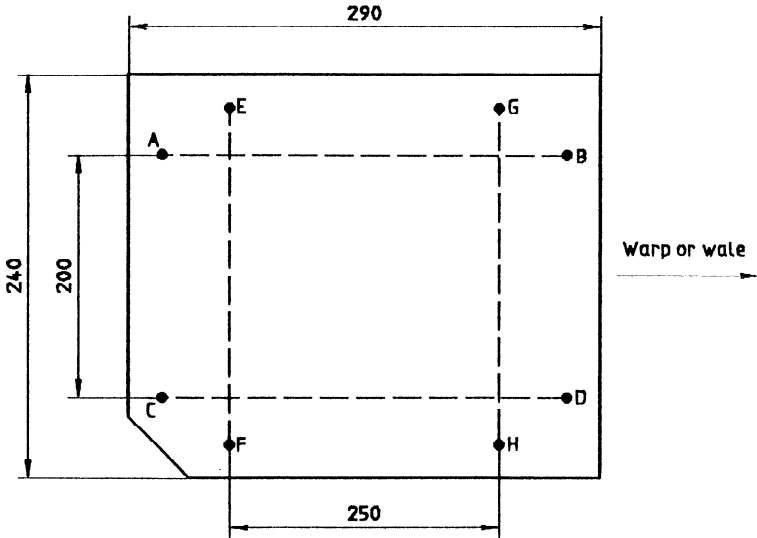

Figure 1 — Test specimens

iTeh STANDARD PREVIEW
(standards.iteh.ai)

<https://standards.iteh.ai/catalog/standards/sist/6156d14e-82c1-4045-bf65-6c5dd00621d0/iso-9866-2-1991>

iTeh STANDARD PREVIEW
(standards.iteh.ai)

This page intentionally left blank
ISO 9866-2:1991

<https://standards.iteh.ai/catalog/standards/sist/6156d14e-82c1-4045-bf65-6c5dd00621d0/iso-9866-2-1991>

iTeh STANDARD PREVIEW
(standards.iteh.ai)

This page intentionally left blank
ISO 9866-2:1991

<https://standards.iteh.ai/catalog/standards/sist/6156d14e-82c1-4045-bf65-6c5dd00621d0/iso-9866-2-1991>

iTeh STANDARD PREVIEW
(standards.iteh.ai)

ISO 9866-2:1991

<https://standards.iteh.ai/catalog/standards/sist/6156d14e-82c1-4045-bf65-6c5dd00621d0/iso-9866-2-1991>

UDC 677.017.56:536.4

Descriptors: textiles, fabrics, tests, dry heat tests, determination, dimensional stability.

Price based on 3 pages
