Aerospace series - Pipe coupling 8°30' in titanium alloy - Tees with thrust wire nut on run

Aerospace series - Pipe coupling 8°30' in titanium alloy - Tees with thrust wire nut on run

Luft- und Raumfahrt - Rohrverschraubung 8°30' aus Titanlegierung - T-Verschraubungen T-Durchgang mit Mutter mit Schubdraht

Série aérospatiale - Systeme de raccordement 8°30' en alliage de titane - Raccords en té avec écrou a jonc en ligne

iTeh STANDARD PREVIEW

(standards.iteh.ai)

[SIST EN 4028:2004](https://standards.iteh.ai/catalog/standards/sist/f3fa0801-001f-4dc5-bd05-04d2417c1a4b/sist-en-4028-2004)

Ta slovenski standard je istoveten z: EN 4028:2001

<https://standards.iteh.ai/catalog/standards/sist/f3fa0801-001f-4dc5-bd05-04d2417c1a4b/sist-en-4028-2004>

ICS:

49.080

Številni sistemi za prenos tekočin in plinov v letalstvu

Aerospace fluid systems and components

SIST EN 4028:2004

en

iTeh STANDARD PREVIEW
(standards.iteh.ai)

[SIST EN 4028:2004](#)

<https://standards.iteh.ai/catalog/standards/sist/f3fa0801-001f-4dc5-bd05-04d2417c1a4b/sist-en-4028-2004>

EUROPEAN STANDARD
NORME EUROPÉENNE
EUROPÄISCHE NORM

EN 4028

October 2001

ICS 49.080

English version

Aerospace series - Pipe coupling 8°30' in titanium alloy - Tees with thrust wire nut on run

Série aérospatiale - Système de raccordement 8°30' en
alliage de titane - Raccords en té avec écrou à jonc en
ligne

Luft- und Raumfahrt - Rohrverschraubung 8°30' aus
Titanlegierung - T-Verschraubungen T-Durchgang mit
Mutter mit Schubdraht

This European Standard was approved by CEN on 29 December 2000.

CEN members are bound to comply with the CEN/CENELEC Internal Regulations which stipulate the conditions for giving this European Standard the status of a national standard without any alteration. Up-to-date lists and bibliographical references concerning such national standards may be obtained on application to the Management Centre or to any CEN member.

This European Standard exists in three official versions (English, French, German). A version in any other language made by translation under the responsibility of a CEN member into its own language and notified to the Management Centre has the same status as the official versions.

CEN members are the national standards bodies of Austria, Belgium, Czech Republic, Denmark, Finland, France, Germany, Greece, Iceland, Ireland, Italy, Luxembourg, Netherlands, Norway, Portugal, Spain, Sweden, Switzerland and United Kingdom.

SIST EN 4028:2004

<https://standards.iteh.ai/catalog/standards/sist/f3fa0801-001f-4dc5-bd05-04d2417c1a4b/sist-en-4028-2004>



EUROPEAN COMMITTEE FOR STANDARDIZATION
COMITÉ EUROPÉEN DE NORMALISATION
EUROPÄISCHES KOMITEE FÜR NORMUNG

Management Centre: rue de Stassart, 36 B-1050 Brussels

EN 4028:2001 (E)

Foreword

This European Standard has been prepared by the European Association of Aerospace Manufacturers (AECMA).

After inquiries and votes carried out in accordance with the rules of this Association, this Standard has received the approval of the National Associations and the Official Services of the member countries of AECMA, prior to its presentation to CEN.

This European Standard shall be given the status of a national standard, either by publication of an identical text or by endorsement, at the latest by April 2002, and conflicting national standards shall be withdrawn at the latest by April 2002.

According to the CEN/CENELEC Internal Regulations, the national standards organizations of the following countries are bound to implement this European Standard: Austria, Belgium, Czech Republic, Denmark, Finland, France, Germany, Greece, Iceland, Ireland, Italy, Luxembourg, Netherlands, Norway, Portugal, Spain, Sweden, Switzerland and the United Kingdom.

iTeh STANDARD PREVIEW (standards.iteh.ai)

[SIST EN 4028:2004](#)

<https://standards.iteh.ai/catalog/standards/sist/f3fa0801-001f-4dc5-bd05-04d2417c1a4b/sist-en-4028-2004>

1 Scope

This standard specifies the characteristics of tees, with thrust wire nut on run, for pipe couplings 8°30', in titanium alloy, for aerospace applications.

Nominal pressure: up to 28 000 kPa

Temperature range: – 55 °C to 135 °C

2 Normative references

This European Standard incorporates by dated or undated reference provisions from other publications. These normative references are cited at the appropriate places in the text and the publications are listed hereafter. For dated references, subsequent amendments to or revisions of any of these publications apply to this European Standard only when incorporated in it by amendment or revision. For undated references the latest edition of the publication referred to applies (including amendments).

ISO 5855-3, *Aerospace — MJ threads — Part 3: Limit dimensions for fittings for fluid systems.*

EN 2424, *Aerospace series — Marking of aerospace products.*

EN 2491, *Aerospace series — Molybdenum disulphide dry lubricants — Coating methods.*

EN 3264, *Aerospace series — Pipe coupling 8°30' in titanium alloy — Thrust wire nuts.*

EN 3273, *Aerospace series — Pipe coupling 8°30' — Dynamic beam seal end for elbows, tees and crosses — Geometric configuration.*

EN 3274, *Aerospace series — Pipe coupling 8°30' — Thread ends — Geometric configuration.*

EN 3275, *Aerospace series — Pipe coupling 8°30' up to 28 000 kPa — Dynamic beam seal — Metric series — Technical specification.*

EN 3311, *Aerospace series — Titanium alloy TI-P64001 — Annealed — Bar for machining — $D \leq 150$ mm.¹⁾*

EN 3312, *Aerospace series — Titanium alloy TI-P64001 — Grade 2 — Annealed — Forgings — $D_e \leq 150$ mm.¹⁾*

EN 3314, *Aerospace series — Titanium alloy TI-P64001 — Solution treated and aged — Bar for machining — $D \leq 75$ mm.¹⁾*

EN 3315, *Aerospace series — Titanium alloy TI-P64001 — Solution treated and aged — Forgings — $D_e \leq 75$ mm.¹⁾*

EN 4032, *Aerospace series — Pipe coupling 8°30' in titanium alloy — Thrust wires.*

3 Required characteristics

3.1 Configuration – Dimensions – Mass

According to figure 1 and table 1. The values apply before lubricating.

Dimensions not specified are at the manufacturer's option provided that the qualification and acceptance requirements of EN 3275, typ II are met.

¹⁾ Published as AECMA Prestandard at the date of publication of this standard

EN 4028:2001 (E)

3.2 Surface roughness

According to figure 1, unless otherwise specified in the design documentation.

3.3 Materials

According to EN 3311 or EN 3314, EN 3312 or EN 3315.

3.4 Surface treatment

Lubrication: according to EN 2491, on threads, sealing faces and contact area between thrust wire and coupling.

Prior to application of the lubricant, the surface shall be abrasive blasted using non-metallic grit.

Film thickness 0,005 mm to 0,013 mm.

3.5 Internal surface finishing

Finishing shall give a radius R of 0,3 mm to 1,0 mm and a surface roughness of 0,8 μm . Hand deburring is not permitted.

Dimensions in millimetres

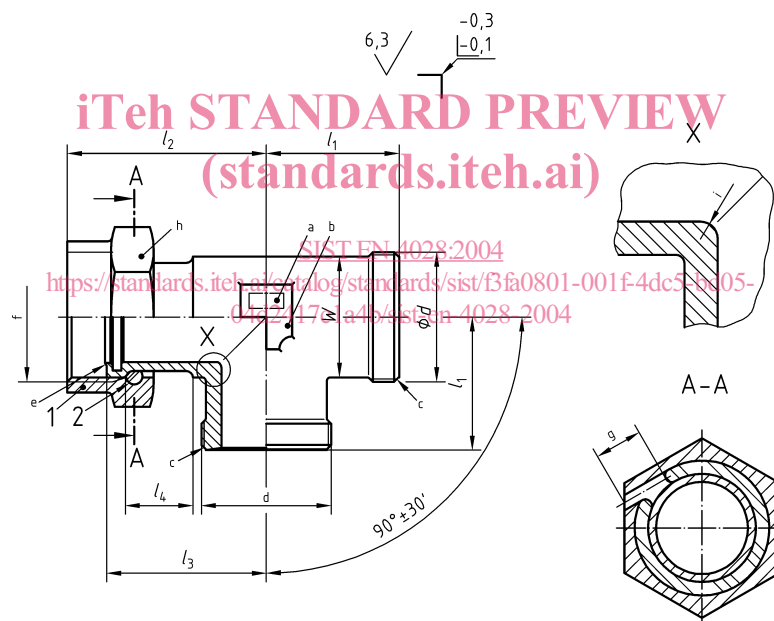

Key

- 1 Nut according to EN 3264
- 2 Thrust wire according to EN 4032

- a Area for marking
- b Across flats s_2
- c According to EN 3274, form C
- d Thread 1
- e According to EN 3273

- f Thread 2
- g Fully inserted
- h Across flats s_1
- i R 0,3 to 1,0

Figure 1

Table 1

Dimensions in millimetres

Code ^a	Thread 1 ^b	Thread 2 ^b	l_1	l_2	l_3	l_4^c	r	s_1	s_2^d	Mass g/piece
	4g6g	4H5H	± 0,2		± 0,2	$\begin{smallmatrix} 0 \\ - 0,2 \end{smallmatrix}$	$\begin{smallmatrix} 0 \\ - 0,1 \end{smallmatrix}$	h13	h13	max.
05	MJ10 × 1	MJ10 × 1	16,3	24,8	19	6,6	1,0	14	8	13,41
06	MJ12 × 1,25	MJ12 × 1,25	17,8	27,7	21	7,5	1,0	16	9	19,10
08	MJ14 × 1,5	MJ14 × 1,5	20,8	32,6	24	9,4	1,0	18	11	25,46
10	MJ16 × 1,5	MJ16 × 1,5	21,8	33,5	25	9,3	1,0	21	13	32,10
12	MJ18 × 1,5	MJ18 × 1,5	23,8	36,2	27	10,5	1,2	22	15	40,52
14	MJ20 × 1,5	MJ20 × 1,5	23,8	37,1	28	10,4	1,2	24	16	48,65
16	MJ22 × 1,5	MJ22 × 1,5	25,8	38,9	30	10,2	1,2	27	18	66,46
18	MJ24 × 1,5	MJ24 × 1,5	27,8	41,1	32	10,9	1,2	30	21	84,21
20	MJ27 × 1,5	MJ27 × 1,5	27,8	44,1	35	10,9	1,5	32	24	100,37
22	MJ30 × 1,5	MJ30 × 1,5	30,8	46,1	37	10,8	1,5	36	27	124,56
25	MJ33 × 1,5	MJ33 × 1,5	32,8	49,1	40	10,8	1,5	41	30	171,36
28	MJ36 × 1,5	MJ36 × 1,5	34,8	52,1	43	10,8	1,5	46	34	202,64
32	MJ39 × 1,5	MJ39 × 1,5	36,4	53,9	45	10,6	1,5	50	36	223,64

^a Corresponds to the pipe nominal outside diameter.

^b According to ISO 5855-3.

^c Only applicable when diameter d_2 according to EN 3273 is smaller than the actual forging diameter. Differences between these diameters are acceptable.

^d Across flats

STANDARD PREVIEW
(standards.iteh.ai)

4 Designation

SIST EN 4028:2004

<https://standards.iteh.ai/catalog/standards/sist/f3fa0801-001f-4dc5-bd05-04d2417c1a4b/sist-en-4028-2004>

EXAMPLE

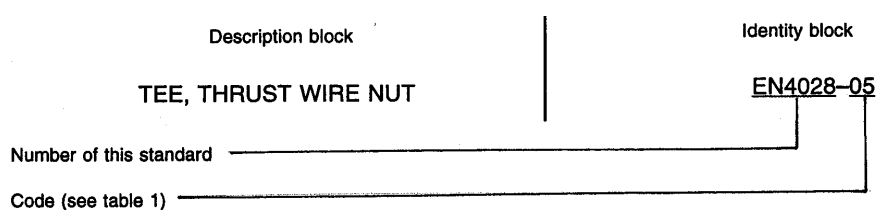

NOTE If necessary, the code I9005 shall be placed between the description block and the identity block.

5 Marking

According to EN 2424, style A and figure 1.

6 Technical specification

According to EN 3275, type II.