



SLOVENSKI STANDARD SIST EN 4183:2004

01-maj-2004

Aerospace series - Pipe coupling 8°30' in titanium alloy - Elbows 90° welded ends

Aerospace series - Pipe coupling 8°30' in titanium alloy - Elbows 90° welded ends

Luft- und Raumfahrt - Rohrverschraubung 8°30' aus Titanlegierung -
Winkelverschraubungen 90° mit Anschweißenden

Série aérospatiale - Systeme de raccordement 8°30' en alliage de titane - Raccords
coudés a 90° doubles, a souder (standards.iteh.ai)

Ta slovenski standard je istoveten z: **EN 4183:2001**
SIST EN 4183:2004
<https://standards.iteh.ai/catalog/standards/sist/08081115-513f-41d8-97a7-46af636799a5/sist-en-4183-2004>

ICS:

49.080 Štepanje [b]a Aerospace fluid systems and components

SIST EN 4183:2004 en

iTeh STANDARD PREVIEW
(standards.iteh.ai)

[SIST EN 4183:2004](#)

<https://standards.iteh.ai/catalog/standards/sist/08081115-513f-41d8-97a7-46af636799a5/sist-en-4183-2004>

iTeh STANDARD PREVIEW
(standards.iteh.ai)

SIST EN 4183:2004

<https://standards.iteh.ai/catalog/standards/sist/08081115-513f-41d8-97a7-46af636799a5/sist-en-4183-2004>

iTeh STANDARD PREVIEW
(standards.iteh.ai)

SIST EN 4183:2004

<https://standards.iteh.ai/catalog/standards/sist/08081115-513f-41d8-97a7-46af636799a5/sist-en-4183-2004>

iTeh STANDARD PREVIEW
(standards.iteh.ai)

SIST EN 4183:2004

<https://standards.iteh.ai/catalog/standards/sist/08081115-513f-41d8-97a7-46af636799a5/sist-en-4183-2004>

iTeh STANDARD PREVIEW (standards.iteh.ai)

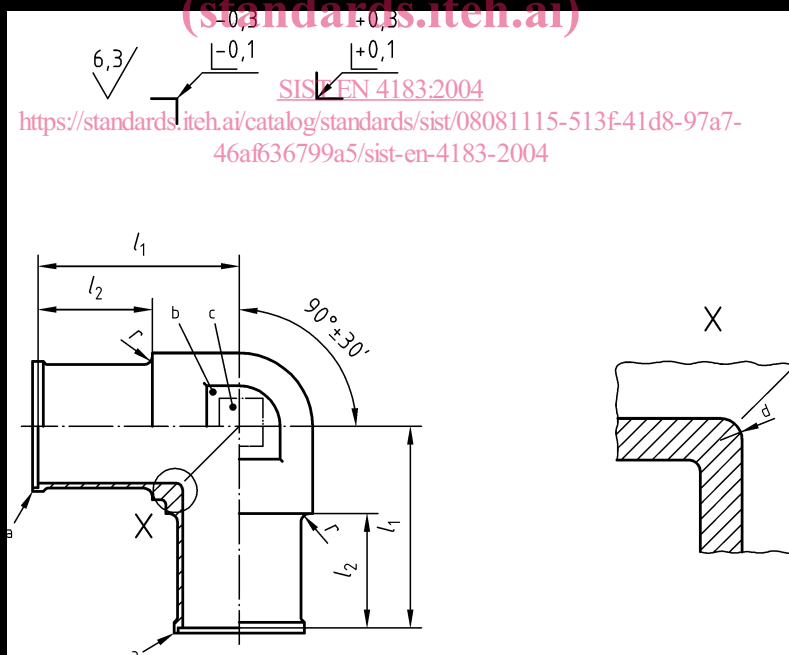

iTeh STANDARD PREVIEW
(standards.iteh.ai)

SIST EN 4183:2004

<https://standards.iteh.ai/catalog/standards/sist/08081115-513f-41d8-97a7-46af636799a5/sist-en-4183-2004>

iTeh STANDARD PREVIEW
(standards.iteh.ai)

SIST EN 4183:2004

<https://standards.iteh.ai/catalog/standards/sist/08081115-513f-41d8-97a7-46af636799a5/sist-en-4183-2004>