



**SLOVENSKI STANDARD
SIST EN 4185:2004**

01-maj-2004

Aerospace series - Pipe coupling 8°30' in titanium alloy - Tees bulkhead on run long

Aerospace series - Pipe coupling 8°30' in titanium alloy - Tees bulkhead on run long

Luft- und Raumfahrt - Rohrverschraubung 8°30' aus Titanlegierung - T-Verschraubungen T-Durchgang als Schottanschluss lange Ausführung

iTeh STANDARD PREVIEW

Série aérospatiale - Systeme de raccordement 8°30' en alliage de titane - Raccords en té pour traversée de cloison en ligne type long

[SIST EN 4185:2004](https://standards.iteh.ai/catalog/standards/sist/ed7ba3f6-9fa2-4b05-8eb7-56cacc075de2/sist-en-4185-2004)

Ta slovenski standard je istoveten z: EN 4185:2001

ICS:

49.080

Številni sistemi za tekočine in pline v letalski in vesoljski tehniki

Aerospace fluid systems and components

SIST EN 4185:2004

en

iTeh STANDARD PREVIEW
(standards.iteh.ai)

[SIST EN 4185:2004](#)

<https://standards.iteh.ai/catalog/standards/sist/ed7ba3f6-9fa2-4b05-8eb7-50caec075de2/sist-en-4185-2004>

EUROPEAN STANDARD
NORME EUROPÉENNE
EUROPÄISCHE NORM

EN 4185

October 2001

ICS 49.080

English version

Aerospace series - Pipe coupling 8°30' in titanium alloy - Tees bulkhead on run long

Série aérospatiale - Système de raccordement 8°30' en
alliage de titane - Raccords en té pour traversée de cloison
en ligne type long

Luft- und Raumfahrt - Rohrverschraubung 8°30' aus
Titanlegierung - T-Verschraubungen T-Durchgang als
Schottanschluss lange Ausführung

This European Standard was approved by CEN on 28 February 2001.

CEN members are bound to comply with the CEN/CENELEC Internal Regulations which stipulate the conditions for giving this European Standard the status of a national standard without any alteration. Up-to-date lists and bibliographical references concerning such national standards may be obtained on application to the Management Centre or to any CEN member.

This European Standard exists in three official versions (English, French, German). A version in any other language made by translation under the responsibility of a CEN member into its own language and notified to the Management Centre has the same status as the official versions.

CEN members are the national standards bodies of Austria, Belgium, Czech Republic, Denmark, Finland, France, Germany, Greece, Iceland, Ireland, Italy, Luxembourg, Netherlands, Norway, Portugal, Spain, Sweden, Switzerland and United Kingdom.

[SIST EN 4185:2004](https://standards.iteh.ai/catalog/standards/sist/en-4185-2004)

<https://standards.iteh.ai/catalog/standards/sist/en-4185-2004>



EUROPEAN COMMITTEE FOR STANDARDIZATION
COMITÉ EUROPÉEN DE NORMALISATION
EUROPÄISCHES KOMITEE FÜR NORMUNG

Management Centre: rue de Stassart, 36 B-1050 Brussels

EN 4185:2001 (E)

Foreword

This European Standard has been prepared by the European Association of Aerospace Manufacturers (AECMA).

After inquiries and votes carried out in accordance with the rules of this Association, this Standard has received the approval of the National Associations and the Official Services of the member countries of AECMA, prior to its presentation to CEN.

This European Standard shall be given the status of a national standard, either by publication of an identical text or by endorsement, at the latest by April 2002, and conflicting national standards shall be withdrawn at the latest by April 2002.

According to the CEN/CENELEC Internal Regulations, the national standards organizations of the following countries are bound to implement this European Standard: Austria, Belgium, Czech Republic, Denmark, Finland, France, Germany, Greece, Iceland, Ireland, Italy, Luxembourg, Netherlands, Norway, Portugal, Spain, Sweden, Switzerland and the United Kingdom.

iTeh STANDARD PREVIEW (standards.iteh.ai)

[SIST EN 4185:2004](#)

<https://standards.iteh.ai/catalog/standards/sist/ed7ba3f6-9fa2-4b05-8eb7-50caec075de2/sist-en-4185-2004>

1 Scope

This standard specifies the characteristics of tees, bulkhead on run, long, for pipe couplings 8°30', in titanium alloy, for aerospace applications.

Nominal pressure: up to 28 000 kPa

Temperature range: – 55 °C to 135 °C

2 Normative references

This European Standard incorporates by dated or undated reference provisions from other publications. These normative references are cited at the appropriate places in the text and the publications are listed hereafter. For dated references, subsequent amendments to or revisions of any of these publications apply to this European Standard only when incorporated in it by amendment or revision. For undated references, the latest edition of the publication referred to applies (including amendments).

ISO 5855-3, *Aerospace series — MJ threads — Part 3: Limit dimensions for fittings for fluid systems.*

EN 2424, *Aerospace series — Marking of aerospace products.*

EN 2491, *Aerospace series — Molybdenum disulphide dry lubricants — Coating methods.*

EN 3267, *Aerospace series — Washers, bulkhead, in titanium alloy.*

EN 3274, *Aerospace series — Pipe coupling 8°30' — Thread ends — Geometric configuration.*

EN 3275, *Aerospace series — Pipe coupling 8°30' up to 28 000 kPa — Dynamic beam seal — Metric series — Technical specification.*

EN 3311, *Aerospace series — Titanium alloy TI-P64001 — Annealed — Bar for machining — $D \leq 150$ mm.¹⁾*

EN 3312, *Aerospace series — Titanium alloy TI-P64001 — Grade 2 — Annealed — Forgings — $D_e \leq 150$ mm.¹⁾*

EN 3314, *Aerospace series — Titanium alloy TI-P64001 — Solution treated and aged — Bar for machining — $D \leq 75$ mm.¹⁾*

EN 3315, *Aerospace series — Titanium alloy TI-P64001 — Solution treated and aged — Forgings — $D_e \leq 75$ mm.¹⁾*

SIST EN 4185:2004
<https://standards.iteh.ai/catalog/standards/sist/en/4185-2004>
 50caec075de2/sist-en-4185-2004

3 Required characteristics

3.1 Configuration — Dimensions — Mass

According to figure 1 and table 1. The values apply before lubricating.

Dimensions not specified are at manufacturer's option provided that the qualification and acceptance requirements of EN 3275, type II, are met.

¹⁾ Published as AECMA Prestandard at the date of publication of this standard

EN 4185:2001 (E)

3.2 Surface roughness

According to figure 1, unless otherwise specified in the design documentation.

3.3 Materials

According to EN 3311 or EN 3314, EN 3312 or EN 3315.

3.4 Surface treatment

Lubrication: according to EN 2491, on threads and sealing faces.

Prior to application of the lubricant, the surface shall be abrasive blasted using non-metallic grit.

Film thickness 0,005 mm to 0,013 mm.

3.5 Internal surface finishing

Finishing shall give a radius R of 0,3 mm to 1,0 mm and a surface roughness of 0,8 μm . Hand deburring is not permitted.

Dimensions in millimetres

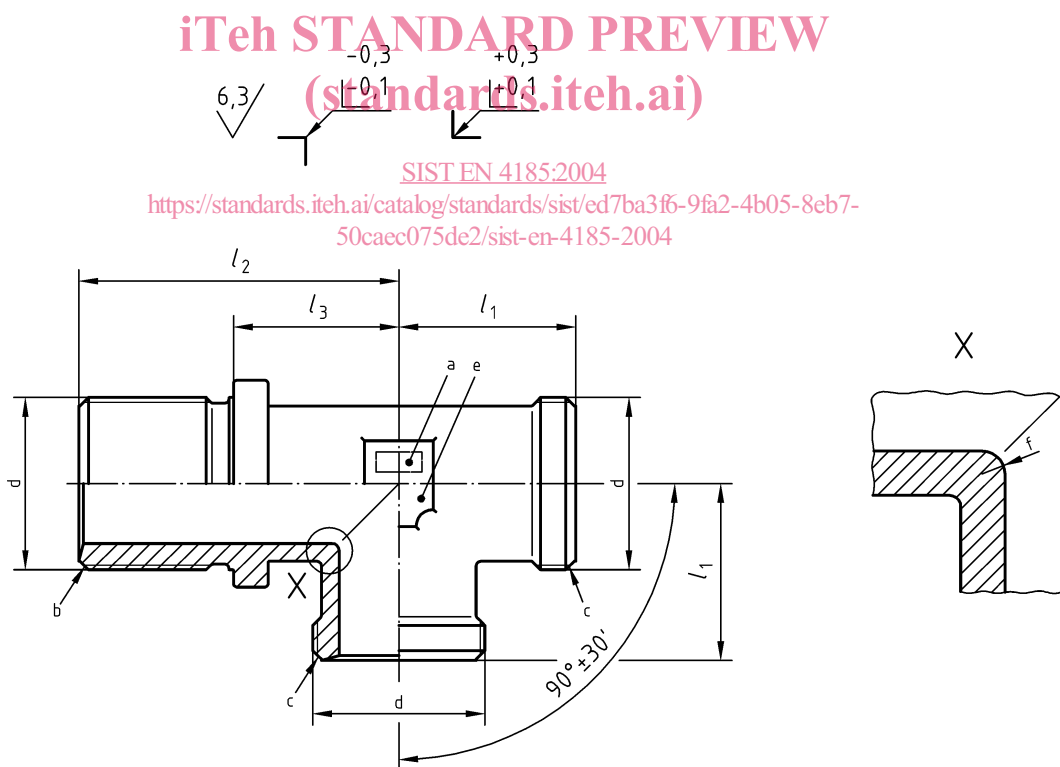

- ^a Area for marking
- ^b According to EN 3274, form H
- ^c According to EN 3274, form C
- ^d Thread
- ^e Across flats s
- ^f R 0,3 to 1,0

Figure 1

Table 1

Dimensions in millimetres

Code ^a	Thread ^b 4g6g	l_1 $\pm 0,2$	l_2 Ref.	l_3 $\pm 0,2$	s^c h13	Mass g/piece max.
05	MJ10 × 1	16,3	33,3	13,8	8	13,62
06	MJ12 × 1,25	17,8	38,0	16,0	9	21,34
08	MJ14 × 1,5	20,8	42,8	17,8	11	30,54
10	MJ16 × 1,5	21,8	44,8	18,8	13	39,35
12	MJ18 × 1,5	23,8	47,8	20,8	15	49,08
14	MJ20 × 1,5	23,8	48,8	21,8	16	62,57
16	MJ22 × 1,5	25,8	50,8	23,8	18	83,90
18	MJ24 × 1,5	27,8	52,8	25,8	21	94,65
20	MJ27 × 1,5	27,8	54,8	27,8	24	117,04
22	MJ30 × 1,5	30,8	55,8	28,8	27	138,86
25	MJ33 × 1,5	32,8	57,8	30,8	30	187,55
28	MJ36 × 1,5	34,8	62,3	33,8	34	237,78
32	MJ39 × 1,5	36,4	68,3	39,8	36	268,12

^a Corresponds to the pipe nominal outside diameter.

^b According to ISO 5855-3.

^c Across flats

iTech STANDARD PREVIEW
(standards.itech.ai)

4 Designation

EXAMPLE

[SIST EN 4185:2004](https://standards.itech.ai/catalog/standards/sist/ed7ba3f6-9fa2-4b05-8eb7-50caec075de2/sist-en-4185-2004)

<https://standards.itech.ai/catalog/standards/sist/ed7ba3f6-9fa2-4b05-8eb7-50caec075de2/sist-en-4185-2004>

Description block

TEE, BULKHEAD ON RUN

Identity block

EN4185-05

Number of this standard _____

Code (see table 1) _____

NOTE If necessary, the code I9005 shall be placed between the description block and the identity block.

5 Marking

According to EN 2424, style A and figure 1.

6 Technical specification

According to EN 3275, type II.

EN 4185:2001 (E)

7 Installation details

See figure 2.

Dimensions in millimetres

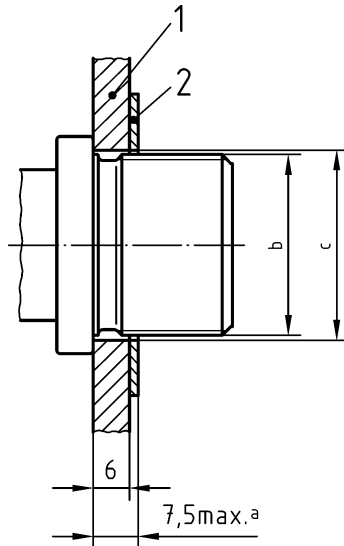
**Key**

- 1 Bulkhead
- 2 Washer according to EN 3267

- ^a Grip length
- ^b Thread
- ^c Thread + 0,5

ITeH STANDARD PREVIEW
(standards.iteh.ai)

SIST EN 4185:2004

<https://standards.iteh.ai/catalog/standards/sist/ed7ba3f6-9fa2-4b05-8eb7-50caec075de2/sist-en-4185-2004> **Figure 2**