

INTERNATIONAL
STANDARD

ISO
12306

First edition
1994-02-15

**Plain bearings — Measurement of wall
thickness of thin-walled half-bearings and
thin-walled bushes**

iTeh STANDARD PREVIEW

*(Paliers lisses — Mesurage de l'épaisseur de paroi des demi-coussinets
minces et des bagues minces)*

[ISO 12306:1994](#)

<https://standards.iteh.ai/catalog/standards/sist/51ae7814-ad6c-440e-bc2c-d61d1ddad768/iso-12306-1994>



Reference number
ISO 12306:1994(E)

Foreword

ISO (the International Organization for Standardization) is a worldwide federation of national standards bodies (ISO member bodies). The work of preparing International Standards is normally carried out through ISO technical committees. Each member body interested in a subject for which a technical committee has been established has the right to be represented on that committee. International organizations, governmental and non-governmental, in liaison with ISO, also take part in the work. ISO collaborates closely with the International Electrotechnical Commission (IEC) on all matters of electrotechnical standardization.

Draft International Standards adopted by the technical committees are circulated to the member bodies for voting. Publication as an International Standard requires approval by at least 75 % of the member bodies casting a vote.

International Standard ISO 12306 was prepared by Technical Committee ISO/TC 123, *Plain bearings*, Subcommittee SC 5, *Quality analysis and assurance*.

<https://standards.iteh.ai/catalog/standards/sist/51ae7814-ad6c-440e-bc2c->

Annex A forms an integral part of this International Standard. Annex B is for information only.

© ISO 1994

All rights reserved. Unless otherwise specified, no part of this publication may be reproduced or utilized in any form or by any means, electronic or mechanical, including photocopying and microfilm, without permission in writing from the publisher.

International Organization for Standardization
Case Postale 56 • CH-1211 Genève 20 • Switzerland

Printed in Switzerland

Plain bearings — Measurement of wall thickness of thin-walled half-bearings and thin-walled bushes

1 Scope

This International Standard describes in accordance with ISO 12301 the checking methods and measuring equipment used for measuring the total wall thickness of thin-walled half-bearings and thin-walled bushes in the finished state.

It is not applicable to thermoplastic bushes.

NOTE 1 All dimensions in this International Standard are given in millimetres.

2 Normative references

(standards.iteh.ai)

The following standards contain provisions which, through reference in this text, constitute provisions of this International Standard. At the time of publication, the editions indicated were valid. All standards are subject to revision, and parties to agreements based on this International Standard are encouraged to investigate the possibility of applying the most recent editions of the standards indicated below. Members of IEC and ISO maintain registers of currently valid International Standards.

ISO 3547:1976, *Plain bearings — Wrapped bushes — Dimensions, tolerances and methods of checking.*

ISO 3548:1978, *Plain bearings — Thin-walled half bearings — Dimensions, tolerances and methods of checking.*

ISO 4379:1993, *Plain bearings — Copper alloy bushes.*

ISO 6864:1984, *Plain bearings — Thin-walled flanged half bearings — Dimensions, tolerances and methods of checking.*

ISO 12301:1992, *Plain bearings — Quality control techniques and inspection of geometrical and material quality characteristics.*

3 Definition

For the purposes of this International Standard, the following definition applies.

3.1 total wall thickness, s_{tot} : Radial distance between the opposing measuring points at the inside and the outside surface diameter. (See figure 1.)

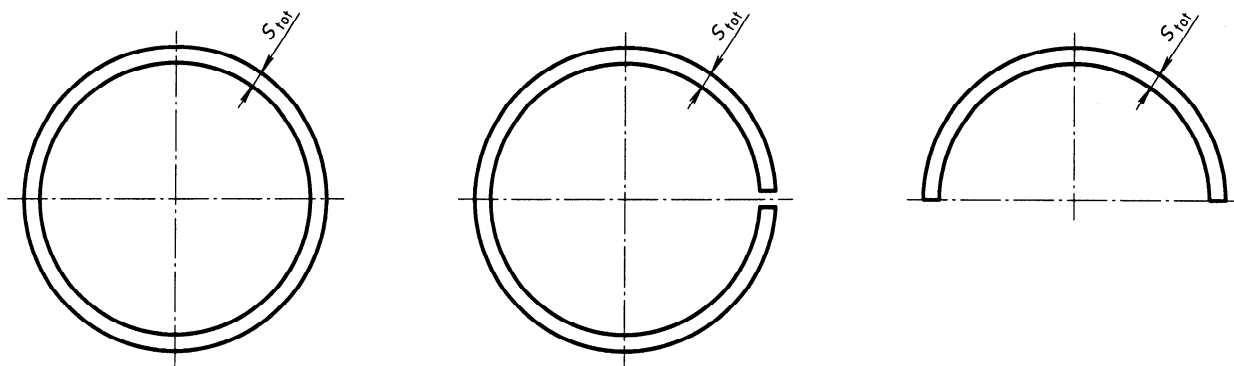

Figure 1 — Total wall thickness, s_{tot}

4 Symbols and units

For the purposes of this International Standard, the symbols and units are as given in table 1.

Table 1 — Symbols and units

Symbol	Parameter	SI unit
a_c	Measuring distance	mm
B	Width	mm
D_o	Outside diameter	mm
F_{pin}	Checking load (measuring pin)	N
n	Number of test pieces	
s_{tot}	Total wall thickness	mm
u	Uncertainty of measurement (confidence level of 95 %)	mm
u_E	Uncertainty of measurement of measuring equipment	mm
Δx	Difference in measured values between first and second readings	mm
$\overline{\Delta x}$	Arithmetic mean of Δx	mm
σ	Standard deviation	mm
$\sigma_{\Delta x}$	Standard deviation of Δx	mm

5 Purpose of checking

In order to guarantee the required bearing clearance and consequently the operational efficiency of the plain bearing unit, it is necessary to keep to the wall thickness tolerances specified in ISO 3547, ISO 3548, ISO 4379 and ISO 6864.

6 Checking methods (see annex A)

6.1 Measuring principle

The gauging axis of the measuring pins shall be in the radial direction and at a right angle to the outside surface of the test piece in order to find the minimum value of the wall thickness. The measured values may be recorded by a single measurement or by sum measurement, which are symbolically represented in figure 2.

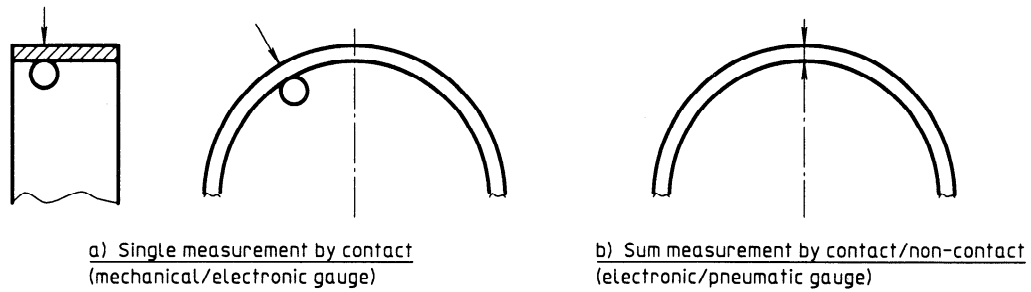

Figure 2 — Measuring principle of wall thickness measurement

The presence of lubricating holes, oil pockets, oil grooves, markings or special chamfers may require deviation from the measuring lines and measuring points specified in the following and shall be agreed upon separately.

Any wall thickness not conforming to the specified values on account of the manufacturing process, because of deformation of the bearing backing in the area of marking or at non-load bearing places of wrapped bushes, shall be defined separately.

6.2 Line measurement around the circumference

Continuous measurement of the wall thickness around the circumference shall be carried out at the measuring lines specified in figure 3 and table 2.

STANDARD PREVIEW
(standards.iteh.ai)

ISO 12306:1994

<https://standards.iteh.ai/catalog/standards/sist/51ae7814-ad6c-440e-bc2c-d61d1ddad768/iso-12306-1994>

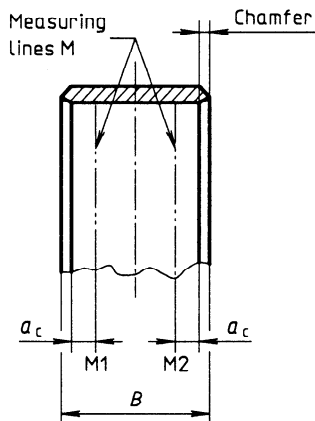

Figure 3 — Position of measuring lines

Table 2 — Measuring line distances a_c

Width B	Measuring distance ¹⁾ a_c	Number of measuring lines M
$B \leq 15$	$B/2$	1
$15 < B \leq 50$	4	2
$50 < B \leq 90$	6 and $B/2$	3
$B > 90$	8 and $B/2$	3

1) Each measuring line distance a_c is specified from the beginning of the sliding surface.

6.3 Line measurement in the axial direction

Continuous measurement of the wall thickness shall be carried out in the axial direction at the measuring lines specified in figures 4 and 5 for widths of $B \leq 50$ mm and outside diameter $D_o \leq 150$ mm.

In the case where $B > 50$ mm and $D_o > 150$ mm, the measurement method shall be subject to agreement between the manufacturer and customer.

6.3.1 Half-bearings

See figure 4

iTeh STANDARD PREVIEW
(standards.iteh.ai)

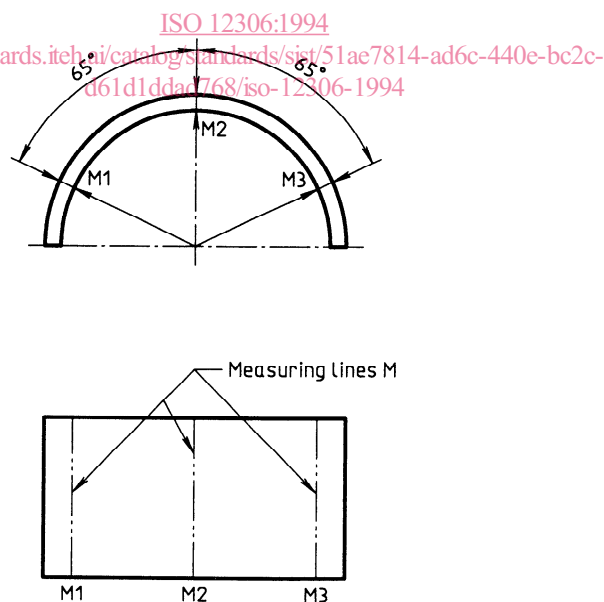

Figure 4 — Three-line measuring scheme for half-bearings with $D_o \leq 150$ mm

6.3.2 Bushes

See figure 5.

This method of measurement may be used for unsplit as well as for wrapped bushes, of ground or calibrated design.

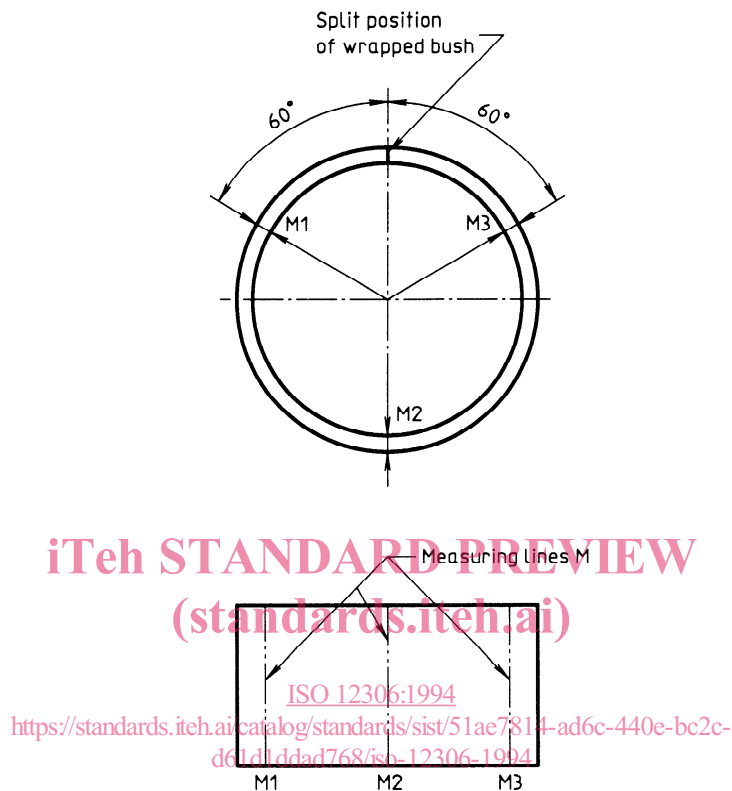

Figure 5 — Three-line measuring scheme for unsplit or wrapped bushes with $D_o \leq 150$ mm

6.4 Point measurement

Point-by-point measurement of wall thickness shall be carried out at the measuring points specified in figures 6 to 8 for widths of $B \leq 90$ mm and outside diameter $D_o \leq 150$ mm. In the case where $B > 90$ mm and $D_o > 150$ mm, the measurement method shall be subject to agreement between the manufacturer and customer. The measuring line distance, a_c , shall be taken from table 2.

6.4.1 Half-bearings

See figures 6 to 8.

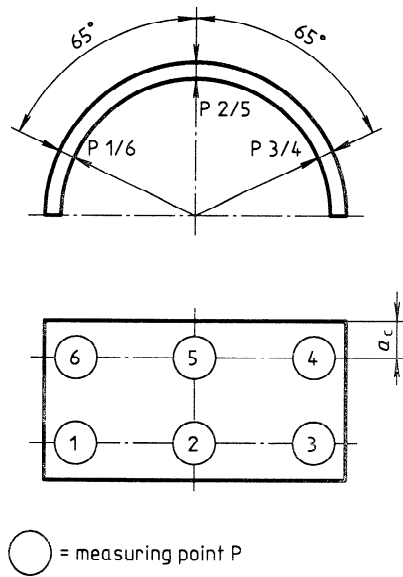

Figure 6 — Six-point measuring scheme for half-bearings with $B \leq 50$ mm and $D_o \leq 80$ mm

iteh STANDARD PREVIEW
(standards.iteh.ai)

ISO 12306:1994
<https://standards.iteh.ai/catalog/standards/sist/51ae7814-ad6c-440e-bc2c-d61d1ddad768/iso-12306-1994>

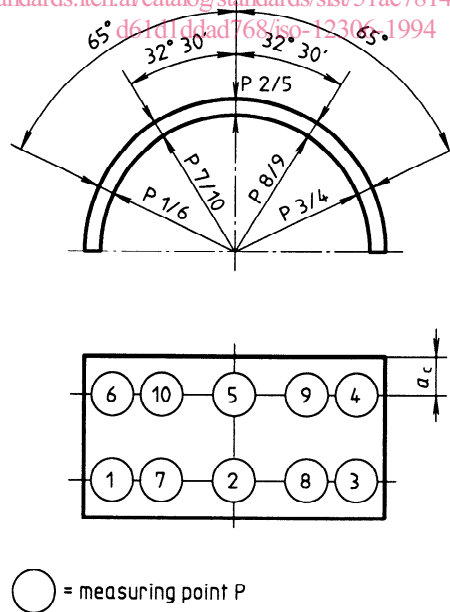
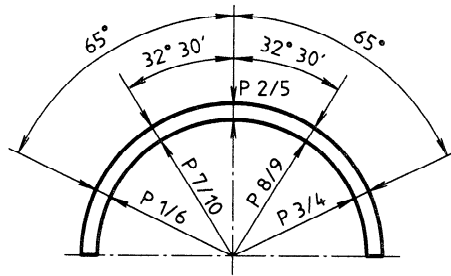
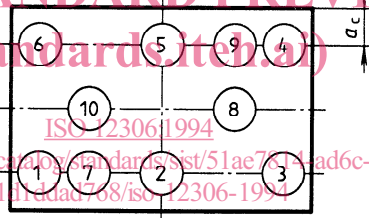

Figure 7 — Ten-point measuring scheme for half-bearings with $B \leq 50$ mm and $D_o \leq 150$ mm



iTeh STANDARD PREVIEW
(standards.iteh.ai)

ISO 12306:1994
<https://standards.iteh.ai/catalog/standards/sist/51ae7813-4ad6c-440e-bc2c-d61f1ddad738/iso-12306-1994>



○ = measuring point P

Figure 8 — Ten-point measuring scheme for half-bearings with $B \leq 90$ mm and $D_o \leq 150$ mm