



Standard Test Method for Bearing Strength of Plastics¹

This standard is issued under the fixed designation D 953; the number immediately following the designation indicates the year of original adoption or, in the case of revision, the year of last revision. A number in parentheses indicates the year of last reapproval. A superscript epsilon (ϵ) indicates an editorial change since the last revision or reapproval.

This standard has been approved for use by agencies of the Department of Defense.

1. Scope

1.1 This test method covers the determination of the bearing strength of rigid plastics in either sheet or molded form. Procedure A is applicable for tension loading and Procedure B for compression loading.

1.2 Test data obtained by this test method is relevant and appropriate for use in engineering design.

1.3 The values stated in SI units are to be regarded as the standard. The values given in parentheses are for information only.

1.4 *This standard does not purport to address all of the safety concerns, if any, associated with its use. It is the responsibility of the user of this standard to establish appropriate safety and health practices and determine the applicability of regulatory limitations prior to use.*

2. Referenced Documents

2.1 ASTM Standards:

D 618 Practice for Conditioning Plastics and Electrical Insulating Materials for Testing²

D 883 Terminology Relating to Plastics²

D 4000 Classification System for Specifying Plastic Materials³

D 4066 Specification for Nylon Injection and Extrusion Materials³

D 4805 Terminology of Plastics Standards⁴

E 4 Practices for Load Verification of Testing Machines⁵

E 6 Terminology Relating to Methods of Mechanical Testing⁵

3. Terminology

3.1 *Definitions*—For definitions of technical terms pertaining to plastics used in this test method, see Terminology D 883

or Terminology D 4805.

3.2 *Definitions of Terms Specific to This Standard:*⁶

3.2.1 *bearing area*—the diameter of the hole multiplied by the thickness of the specimen.

3.2.2 *bearing strength*—the bearing stress at which the bearing hole is deformed 4 % of its diameter.

3.2.3 *bearing stress*—the applied load in newtons (or pounds-force) divided by the bearing area.

3.2.4 *edge distance ratio*—the distance from the center of the bearing hole to the edge of the specimen in the direction of the principle stress, divided by the diameter of the hole.

3.2.5 *maximum bearing stress*—the maximum load in newtons (or pounds-force) sustained by the specimen, divided by the bearing area.

4. Significance and Use

4.1 This bearing strength test for plastics is intended to apply in the specification of various thermoplastic or thermosetting products in sheet form where rivets, bolts, or similar fastenings are to be used in joining members or sections. It also is intended to apply wherever sheet materials of the classes indicated are required to sustain edgewise loads that are applied by means of pins or rods of circular cross section which pierce the sheet perpendicular to the surface.

4.2 The purpose of the test is to determine the bearing strength of the material and to show the bearing stress versus the deformation of the hole. The allowable deformation of the hole in the material should be such as to produce no looseness of joints.

4.3 While it is a known fact that higher strength materials will generally give higher bearing strengths, there is no satisfactory method by which bearing strength may be estimated from tensile or compressive properties of the material.

4.4 For many materials, there may be a specification that requires the use of this test method, but with some procedural modifications that take precedence when adhering to the specification. Therefore, it is advisable to refer to that material

¹ This test method is under the jurisdiction of ASTM Committee D-20 on Plastics and is the direct responsibility of Subcommittee D20.10 on Mechanical Properties. Current edition approved Oct. 10, 1995. Published December 1995. Originally published as D 953 – 48 T. Last previous edition D 953 – 93.

² *Annual Book of ASTM Standards*, Vol 08.01.

³ *Annual Book of ASTM Standards*, Vol 08.02.

⁴ *Annual Book of ASTM Standards*, Vol 08.03.

⁵ *Annual Book of ASTM Standards*, Vol 03.01.

⁶ Attention is also directed to Terminology E 6.

specification before using this test method. Table 1 of Classification System D 4000 lists the ASTM materials standards that currently exist.

5. Apparatus

5.1 *Testing Machine*—A properly calibrated universal testing machine that can be operated at a speed of 1.3 ± 0.3 mm (0.05 ± 0.01 in.)/min, except that in cases of certain types of material it may be necessary to operate at a slower speed. The percentage of error of the testing machine shall be no more than $\pm 1\%$ of the applied load as determined in accordance with Practices E 4.

5.2 *Tension Loading Fixture*—A three-plate fixture of hardened steel similar to that shown in Fig. 1.

5.3 *Extension Indicator*—A suitable instrument reading in 0.0025 mm (0.0001 in.) for indicating the movement of the free end of the specimen with relation to the bearing pin in the tension loading fixture. A dial gage fitted with accessories for this purpose is shown in Fig. 2.

5.4 *Compression Loading Fixture*—A type of support with a suitable bearing pin similar to Fig. 3.

5.5 *Compression Indicator*—A suitable instrument reading to 0.0025 mm (0.0001 in.) for indicating the movement of the free end of the specimen with relation to the bearing pin in the

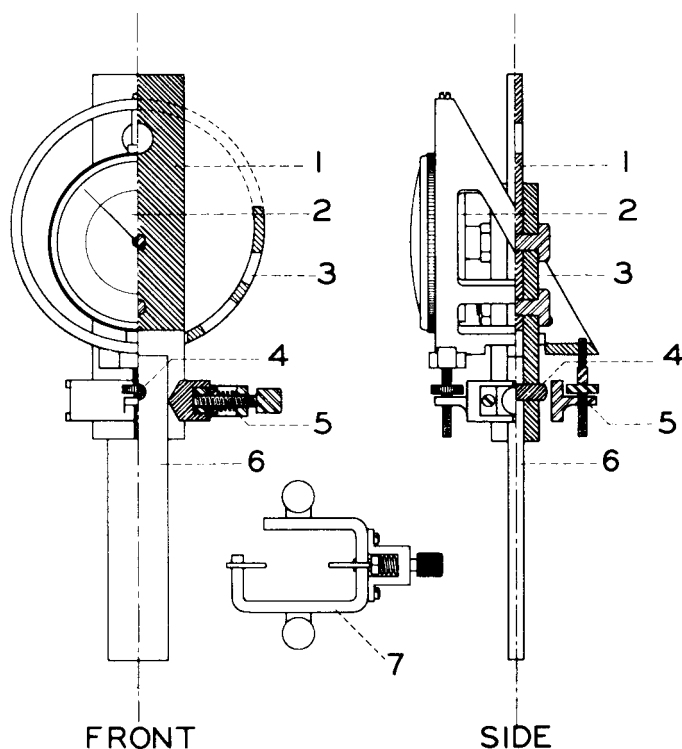

- 1—Spacer plate.
- 2—Dial gage.
- 3—Double foot ring mounted on spindle of dial gage.
- 4—Bearing pin.
- 5—Yoke mounted on specimen.
- 6—Test specimen.
- 7—Plan view of yoke.

FIG. 2 Tension Loading Assembly

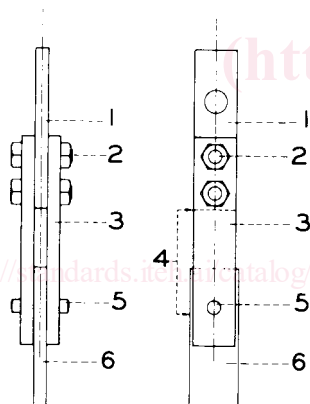

- 1—Hardened spacer plate.
- 2—6.3-mm (-in.) steel bolts in reamed holes.
- 3—Hardened side plate.
- 4—Extensometer span.
- 5—Hardened steel pin in reamed hole.
- 6—Test specimen.

Note—Critical dimensions are as follows:

Type	Bearing Hole Diameter, mm (in.)	Bearing Pin Diameter, mm (in.)	Thickness of Spacer Plate, mm ^A (in.)
I	3.175 + 0.025	3.150 + 0.000	3.2
	- 0.000	- 0.025	
	(0.125 + 0.0010 - 0.0000)	(0.124 + 0.0000 - 0.0010)	($\frac{1}{8}$)
II	6.350 + 0.025	6.325 + 0.000	6.3
	- 0.000	- 0.025	
	(0.250 + 0.0010 - 0.0000)	(0.249 + 0.0000 - 0.0010)	($\frac{1}{4}$)

^A The spacer plate shall be shimmed to a thickness of 0.025 to 0.125 mm (0.001 to 0.005 in.) greater than the specimen under test.

FIG. 1 Steel Tension Loading Fixture

compression loading fixture. A suggested dial gage assembly for this purpose is shown in Fig. 4.

6. Test Specimens

6.1 The test specimens shall conform to the dimensions shown in Fig. 5. A size of test specimen shall be chosen that most nearly conforms to production requirements of the material and the type of loading under consideration. The thicker specimens with the larger bearing hole are likely to give the more precise results, although it is advantageous to use the thinner specimens with the smaller bearing hole in testing certain relatively brittle plastics because they are less likely to fail prematurely. The specimen may be machined from sheet or molded to finished size. The bearing hole shall be located as shown in Fig. 5. It shall be drilled undersized and reamed to size as indicated. The hole shall be clean and smooth with sharp edges but not polished. It is suggested that the reaming operation be done in the drill press by hand without the use of a jig.

7. Number of Test Specimens

7.1 At least five specimens shall be tested for each sample in the case of isotropic materials.

7.2 Ten specimens, five perpendicular to and five parallel with the principal axis of anisotropy, shall be tested for each sample in case of anisotropic materials.

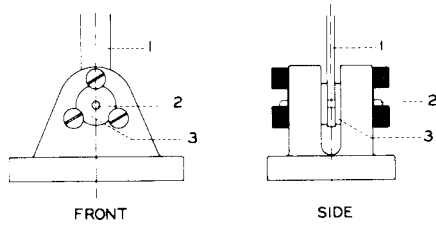

- 1—Test specimen.
2—Hardened steel pin.
3—Hardened thrust bushing.

Note—Critical dimensions are as follows:

Type	Bearing Hole Diameter, mm (in.)	Bearing Pin Diameter, mm (in.)	Minimum Clearance Between Bushings, mm (in.)
I	3.175 + 0.025 - 0.000	3.150 + 0.000 - 0.025	2.8
	(0.125 + 0.0010 - 0.0000)	(0.124 + 0.0000 - 0.0010)	(7/64)
II	6.350 + 0.025 - 0.000	6.325 + 0.000 - 0.025	6.0
	(0.250 + 0.0010 - 0.0000)	(0.249 + 0.0000 - 0.0010)	(15/64)

FIG. 3 Steel Compression Loading Fixture

7.3 Specimens that break at some obvious fortuitous flaw shall be discarded and retests made, unless such flaws constitute a variable the effect of which it is desired to study.

8. Conditioning

8.1 *Conditioning*—Condition the test specimens at $23 \pm 2^\circ\text{C}$ ($73.4 \pm 3.6^\circ\text{F}$) and $50 \pm 5\%$ relative humidity for not less than 40 h prior to test in accordance with Procedure A of Practice D 618, for those tests where conditioning is required. In cases of disagreement, the tolerances shall be $\pm 1^\circ\text{C}$ ($\pm 1.8^\circ\text{F}$) and $\pm 2\%$ relative humidity.

8.1.1 Note that for some hygroscopic materials, such as nylons, the material specifications (for example, Specification D 4066) call for testing “dry as-molded specimens.” Such requirements take precedence over the above routine preconditioning to 50 % relative humidity and require sealing the specimens in water vapor-impermeable containers as soon as molded and not removing them until ready for testing.

8.2 *Test Conditions*—Conduct tests in the standard laboratory atmosphere of $23 \pm 2^\circ\text{C}$ ($73.4 \pm 3.6^\circ\text{F}$) and $50 \pm 5\%$ relative humidity, unless otherwise specified in the test method. In cases of disagreements, the tolerances shall be $\pm 1^\circ\text{C}$ ($\pm 1.8^\circ\text{F}$) and $\pm 2\%$ relative humidity.

9. Measurement of Dimensions

9.1 Measure the width and thickness of the conditioned test specimen to the nearest 0.025 mm (0.001 in.) at the bearing hole. Also measure the diameter of the bearing hole and the distance from the center of the bearing hole to the edge of the specimen in the direction of the principle stress to the nearest 0.025 mm (0.001 in.).

10. Speed of Testing

10.1 The mean rate of crosshead travel in the testing of

specimens shall not exceed 1.3 ± 0.3 mm (0.05 ± 0.01 in.)/min. In any case the crosshead movement shall be slow enough so that deflection gage readings can be made accurately.

11. Procedure

11.1 The choice of either Procedure A for tension loading (11.2) or Procedure B for compression loading (11.3) is optional, but it should be recognized that Procedure B gives higher bearing strength values than Procedure A on the same material. Test specimens according to both Procedures A and B if a complete specification of bearing strength is required.

11.2 *Procedure A for Tension Loading*—Mount the specimen to be tested in the tension loading fixture and attach a deformation indicator. If a dial gage (Fig. 2) is used, adjust the yoke so that contact is made with the specimen at the level indicated in Fig. 1. Exception is taken in the case of those thermoplastic materials which exhibit extended plastic flow. Such specimens tend to “neck down” in the region of the bearing hole, and it is necessary to mount the yoke 12.7 mm ($\frac{1}{2}$ in.) below the normal position indicated in A, Fig. 1, so that it will not slip during test.

11.3 *Procedure B for Compression Loading*—Mount the specimen to be tested in the compression loading fixture and load through a flat, hardened compression plate. Adjust the clearance between the thrust bushings of the loading fixture such that their contact with the specimen is sufficient to support it in a vertical position without binding. Clamp the hardwood cheek blocks in place and attach the deformation indicator (see Fig. 4).

11.4 *Details Common to Procedures A and B*—Take care in aligning the long axis of the specimen with the center line of the testing fixture. Load the specimen at the prescribed rate of crosshead travel and take deformation readings. In case autographic recording is not available, record the load sustained by the specimen for every 0.0127-mm (0.0005-in.) deformation up to a total deformation of 4 % of the bearing hole diameter. Continue the test until maximum load is sustained and the corresponding deformation of the bearing hole is recorded.

12. Calculation

12.1 Plot the load - deflection curve for each specimen.

12.2 Use a template, as described in the Appendix, to determine the load at 4 % hole deformation.

12.3 Calculate the bearing strength as follows:

$$S_b = P/td \quad (1)$$

where:

S_b = bearing strength, Pa (or psi),

P = bearing load at 4 % hole deformation, N (or lbf),

d = bearing hole diameter, m (or in.), and

t = specimen thickness, m (or in.).

12.4 Calculate the arithmetic mean of the observations and report the result to three significant figures.

12.5 Calculate the standard deviation of each set of observations and record to two significant figures.

13. Report

13.1 Report the following information: