



Designation: C 496 – 96

Standard Test Method for Splitting Tensile Strength of Cylindrical Concrete Specimens¹

This standard is issued under the fixed designation C 496; the number immediately following the designation indicates the year of original adoption or, in the case of revision, the year of last revision. A number in parentheses indicates the year of last reapproval. A superscript epsilon (ϵ) indicates an editorial change since the last revision or reapproval.

This standard has been approved for use by agencies of the Department of Defense.

1. Scope

1.1 This test method covers the determination of the splitting tensile strength of cylindrical concrete specimens, such as molded cylinders and drilled cores.

NOTE 1—For methods of molding cylindrical concrete specimens, see Practice C 192 and Practice C 31. For methods of obtaining drilled cores see Test Method C 42.

1.2 The values stated in inch-pound units are to be regarded as the standard.

1.3 *This standard does not purport to address all of the safety concerns, if any, associated with its use. It is the responsibility of the user of this standard to establish appropriate safety and health practices and determine the applicability of regulatory limitations prior to use.*

2. Referenced Documents

2.1 ASTM Standards:

- C 31 Practice for Making and Curing Concrete Test Specimens in the Field²
- C 39 Test Method for Compressive Strength of Cylindrical Concrete Specimens²
- C 42 Test Method for Obtaining and Testing Drilled Cores and Sawed Beams of Concrete²
- C 192 Practice for Making and Curing Concrete Test Specimens in the Laboratory²
- C 670 Practice for Preparing Precision and Bias Statements for Test Methods for Construction Materials²

3. Summary of Test Method

3.1 This test method consists of applying a diametral compressive force along the length of a cylindrical concrete specimen at a rate that is within a prescribed range until failure occurs. This loading induces tensile stresses on the plane containing the applied load and relatively high compressive

stresses in the area immediately around the applied load. Tensile failure occurs rather than compressive failure because the areas of load application are in a state of triaxial compression, thereby allowing them to withstand much higher compressive stresses than would be indicated by a uniaxial compressive strength test result.

3.2 Thin, plywood bearing strips are used so that the load is applied uniformly along the length of the cylinder.

3.3 The maximum load sustained by the specimen is divided by appropriate geometrical factors to obtain the splitting tensile strength.

4. Significance and Use

4.1 Splitting tensile strength is simpler to determine than direct tensile strength.

4.2 Splitting tensile strength is used to evaluate the shear resistance provided by concrete in reinforced lightweight aggregate concrete members.

5. Apparatus

5.1 *Testing Machine*—The testing machine shall conform to the requirements of Test Method C 39 and may be of any type of sufficient capacity that will provide the rate of loading prescribed in 7.5.

5.2 *Supplementary Bearing Bar or Plate*—If the diameter or the largest dimension of the upper bearing face or the lower bearing block is less than the length of the cylinder to be tested, a supplementary bearing bar or plate of machined steel shall be used. The surfaces of the bar or plate shall be machined to within ± 0.001 in. (0.025 mm) of planeness, as measured on any line of contact of the bearing area. It shall have a width of at least 2 in. (51 mm), and a thickness not less than the distance from the edge of the spherical or rectangular bearing block to the end of the cylinder. The bar or plate shall be used in such manner that the load will be applied over the entire length of the specimen.

5.3 *Bearing Strips*—Two bearing strips of nominal $\frac{1}{8}$ in. (3.2 mm) thick plywood, free of imperfections, approximately 1 in. (25 mm) wide, and of a length equal to, or slightly longer than, that of the specimen shall be provided for each specimen. The bearing strips shall be placed between the specimen and

¹ This test method is under the jurisdiction of ASTM Committee C-9 on Concrete and Concrete Aggregates and is the direct responsibility of Subcommittee C09.61 on Testing Concrete for Strength.

Current edition approved Jan. 10, 1996. Published March 1996. Originally published as C 496 – 62. Last previous edition C 496 – 90.

² *Annual Book of ASTM Standards*, Vol 04.02.

both the upper and lower bearing blocks of the testing machine or between the specimen and supplemental bars or plates, if used (see 5.2). Bearing strips shall not be reused.

6. Test Specimens

6.1 The test specimens shall conform to the size, molding, and curing requirements set forth in either Practice C 31 (field specimens) or Practice C 192 (laboratory specimens). Drilled cores shall conform to the size and moisture-conditioning requirements set forth in Test Method C 42. Moist-cured specimens, during the period between their removal from the curing environment and testing, shall be kept moist by a wet burlap or blanket covering, and shall be tested in a moist condition as soon as practicable.

6.2 The following curing procedure shall be used for evaluations of light-weight concrete: specimens tested at 28 days shall be in an air-dry condition after 7 days moist curing followed by 21 days drying at $73 \pm 3^\circ\text{F}$ ($23.0 \pm 1.7^\circ\text{C}$) and $50 \pm 5\%$ relative humidity.

7. Procedure

7.1 *Marking*—Draw diametral lines on each end of the specimen using a suitable device that will ensure that they are in the same axial plane (see Fig. 1, Fig. 2 and Note 2), or as an alternative, use the aligning jig shown in Fig. 3 (Note 3).

NOTE 2—Figs. 1 and 2 show a suitable device for drawing diametral lines on each end of the specimen in the same axial plane. The device consists of three parts as follows:

(1) A length of 4-in. (100-mm) steel channel, the flanges of which have been machined flat,

(2) A section of a tee bar, *B*, that is grooved to fit smoothly over the flanges of the channel and that includes a rectangular notch for positioning the vertical member of the tee bar assembly, and

(3) A vertical bar, *C*, containing a longitudinal aperture (cleft), *A*, for guiding a pencil.

The tee bar assembly is not fastened to the channel and is positioned at either end of the channel without disturbing the position of the specimen when marking the diametral lines.

NOTE 3—Fig. 4 is a detailed drawing of the aligning jig shown in Fig. 3 for achieving the same purpose as marking the diametral lines. The device consists of:

(1) A base for holding the lower bearing strip and cylinder,

(2) A supplementary bearing bar conforming to the requirements in Section 5 as to critical dimensions and planeness, and

(3) Two uprights to serve for positioning the test cylinder, bearing strips, and supplementary bearing bar.

7.2 *Measurements*—Determine the diameter of the test specimen to the nearest 0.01 in. (0.25 mm) by averaging three diameters measured near the ends and the middle of the specimen and lying in the plane containing the lines marked on the two ends. Determine the length of the specimen to the nearest 0.1 in. (2.5 mm) by averaging at least two length measurements taken in the plane containing the lines marked on the two ends.

7.3 *Positioning Using Marked Diametral Lines*—Center one of the plywood strips along the center of the lower bearing block. Place the specimen on the plywood strip and align so that the lines marked on the ends of the specimen are vertical and centered over the plywood strip. Place a second plywood strip lengthwise on the cylinder, centered on the lines marked on the ends of the cylinder. Position the assembly to ensure the following conditions:

7.3.1 The projection of the plane of the two lines marked on the ends of the specimen intersects the center of the upper bearing plate, and

7.3.2 The supplementary bearing bar or plate, when used, and the center of the specimen are directly beneath the center of thrust of the spherical bearing block (see Fig. 5).

7.4 *Positioning by Use of Aligning Jig*—Position the bearing strips, test cylinder, and supplementary bearing bar by means of the aligning jig as illustrated in Fig. 3 and center the jig so that the supplementary bearing bar and the center of the specimen are directly beneath the center of thrust of the spherical bearing block.

7.5 *Rate of Loading*—Apply the load continuously and without shock, at a constant rate within the range 100 to 200 psi/min (689 to 1380 kPa/min) splitting tensile stress until failure of the specimen (Note 4). Record the maximum applied load indicated by the testing machine at failure. Note the type of failure and the appearance of the concrete.

NOTE 4—The relationship between splitting tensile stress and applied load is shown in Section 8. The required loading range in splitting tensile

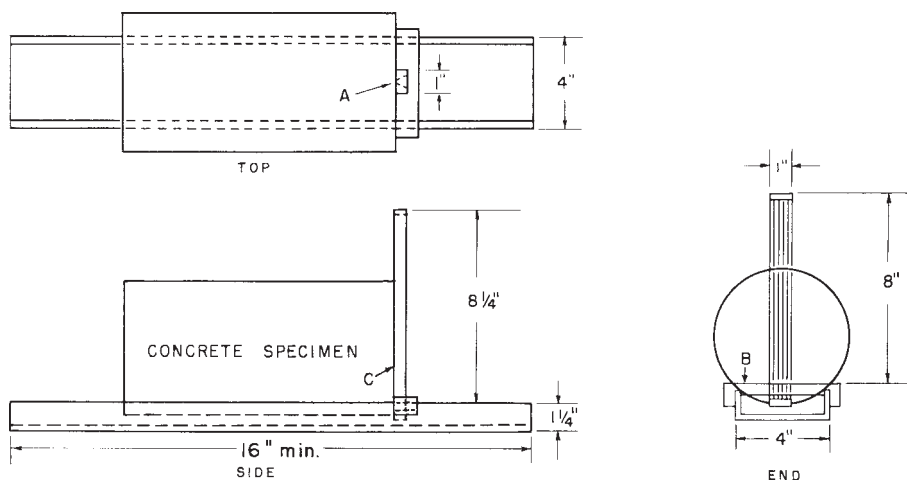

FIG. 1 General Views of a Suitable Apparatus for Marking End Diameters Used for Alignment of Specimen in Testing Machine