



Standard Test Method for Compressive Properties of Rigid Plastics¹

This standard is issued under the fixed designation D 695; the number immediately following the designation indicates the year of original adoption or, in the case of revision, the year of last revision. A number in parentheses indicates the year of last reapproval. A superscript epsilon (ϵ) indicates an editorial change since the last revision or reapproval.

This standard has been approved for use by agencies of the Department of Defense.

1. Scope

1.1 This test method covers the determination of the mechanical properties of unreinforced and reinforced rigid plastics, including high-modulus composites, when loaded in compression at relatively low uniform rates of straining or loading. Test specimens of standard shape are employed.

1.2 The values stated in SI units are to be regarded as the standard. The values in parentheses are for information only.

NOTE 1—For compressive properties of resin-matrix composites reinforced with oriented continuous, discontinuous, or cross-ply reinforcements, tests may be made in accordance with Test Method D 3410.

1.3 *This standard does not purport to address all of the safety concerns, if any, associated with its use. It is the responsibility of the user of this standard to establish appropriate safety and health practices and determine the applicability of regulatory limitations prior to use.* A specific precautionary statement is given in Note 11.

NOTE 2—This test method is technically equivalent to ISO 604.

2. Referenced Documents

2.1 ASTM Standards:

- D 618 Practice for Conditioning Plastics and Electrical Insulating Materials for Testing²
- D 638 Test Method for Tensile Properties of Plastics²
- D 3410 Test Method for Compressive Properties of Unidirectional or Crossply Fiber-Resin Composites³
- D 4000 Classification System for Specifying Plastic Materials⁴
- D 4066 Specification for Nylon Injection and Extrusion Materials⁴
- E 4 Practices for Load Verification of Testing Machines⁵
- E 83 Practice for Verification and Classification of Extensometers⁵
- E 691 Practice for Conducting an Interlaboratory Study to

¹ This test method is under the jurisdiction of ASTM Committee D-20 on Plastics and is the direct responsibility of Subcommittee D20.10 on Mechanical Properties. Current edition approved April 10, 1996. Published July 1996. Originally published as D 695 – 42 T. Last previous edition D 695 – 91.

² *Annual Book of ASTM Standards*, Vol 08.01.

³ *Annual Book of ASTM Standards*, Vol 15.03.

⁴ *Annual Book of ASTM Standards*, Vol 08.02.

⁵ *Annual Book of ASTM Standards*, Vol 03.01.

Determine the Precision of Test Method⁶

3. Terminology

3.1 Definitions:

3.1.1 *compressive deformation*—the decrease in length produced in the gage length of the test specimen by a compressive load. It is expressed in units of length.

3.1.2 *compressive strain*—the ratio of compressive deformation to the gage length of the test specimen, that is, the change in length per unit of original length along the longitudinal axis. It is expressed as a dimensionless ratio.

3.1.3 *compressive strength*—the maximum compressive stress (nominal) carried by a test specimen during a compression test. It may or may not be the compressive stress (nominal) carried by the specimen at the moment of rupture.

3.1.4 *compressive strength at failure (nominal)*—the compressive stress (nominal) sustained at the moment of failure of the test specimen if shattering occurs.

3.1.5 *compressive stress (nominal)*—the compressive load per unit area of minimum original cross section within the gage boundaries, carried by the test specimen at any given moment. It is expressed in force per unit area.

3.1.5.1 *Discussion*—The expression of compressive properties in terms of the minimum original cross section is almost universally used. Under some circumstances the compressive properties have been expressed per unit of prevailing cross section. These properties are called “true” compressive properties.

3.1.6 *compressive stress-strain diagram*—a diagram in which values of compressive stress are plotted as ordinates against corresponding values of compressive strain as abscissas.

3.1.7 *compressive yield point*—the first point on the stress-strain diagram at which an increase in strain occurs without an increase in stress.

3.1.8 *compressive yield strength*—normally the stress at the yield point (see also section 3.113.1.11).

3.1.9 *crushing load*—the maximum compressive force applied to the specimen, under the conditions of testing, that produces a designated degree of failure.

3.1.10 *modulus of elasticity*—the ratio of stress (nominal) to

⁶ *Annual Book of ASTM Standards*, Vol 14.02.



corresponding strain below the proportional limit of a material. It is expressed in force per unit area based on the average initial cross-sectional area.

3.1.11 *offset compressive yield strength*—the stress at which the stress-strain curve departs from linearity by a specified percent of deformation (offset).

3.1.12 *percent compressive strain*—the compressive deformation of a test specimen expressed as a percent of the original gage length.

3.1.13 *proportional limit*—the greatest stress that a material is capable of sustaining without any deviation from proportionality of stress to strain (Hooke's law). It is expressed in force per unit area.

3.1.14 *slenderness ratio*—the ratio of the length of a column of uniform cross section to its least radius of gyration. For specimens of uniform rectangular cross section, the radius of gyration is 0.289 times the smaller cross-sectional dimension. For specimens of uniform circular cross section, the radius of gyration is 0.250 times the diameter.

4. Significance and Use

4.1 Compression tests provide information about the compressive properties of plastics when employed under conditions approximating those under which the tests are made. For many materials, there may be a specification that requires the use of this test method, but with some procedural modifications that take precedence when adhering to the specification. Therefore, it is advisable to refer to that material specification before using this test method. Table 1 in Classification D 4000 lists the ASTM materials standards that currently exist.

4.2 Compressive properties include modulus of elasticity, yield stress, deformation beyond yield point, and compressive strength (unless the material merely flattens but does not fracture). Materials possessing a low order of ductility may not exhibit a yield point. In the case of a material that fails in compression by a shattering fracture, the compressive strength has a very definite value. In the case of a material that does not fail in compression by a shattering fracture, the compressive strength is an arbitrary one depending upon the degree of distortion that is regarded as indicating complete failure of the material. Many plastic materials will continue to deform in compression until a flat disk is produced, the compressive stress (nominal) rising steadily in the process, without any well-defined fracture occurring. Compressive strength can have no real meaning in such cases.

4.3 Compression tests provide a standard method of obtaining data for research and development, quality control, acceptance or rejection under specifications, and special purposes. The tests cannot be considered significant for engineering design in applications differing widely from the load-time scale of the standard test. Such applications require additional tests such as impact, creep, and fatigue.

4.4 Before proceeding with this test method, reference should be made to the specification of the material being tested. Any test specimen preparation, conditioning, dimensions, and testing parameters covered in the materials specification shall take precedence over those mentioned in this test method. If there is no material specification, then the default conditions apply.

5. Apparatus

5.1 *Testing Machine*—Any suitable testing machine capable of control of constant-rate-of-crosshead movement and comprising essentially the following:

5.1.1 *Drive Mechanism*—A drive mechanism for imparting to the cross-head movable member, a uniform, controlled velocity with respect to the base (fixed member), with this velocity to be regulated as specified in Section 9.

5.1.2 *Load Indicator*—A load-indicating mechanism capable of showing the total compressive load carried by the test specimen. The mechanism shall be essentially free from inertia-lag at the specified rate of testing and shall indicate the load with an accuracy of $\pm 1\%$ of the maximum indicated value of the test (load). The accuracy of the testing machine shall be verified at least once a year in accordance with Practices E 4.

5.2 *Compressometer*—A suitable instrument for determining the distance between two fixed points on the test specimen at any time during the test. It is desirable that this instrument automatically record this distance (or any change in it) as a function of the load on the test specimen. The instrument shall be essentially free of inertia-lag at the specified rate of loading and shall conform to the requirements for a Class B-2 extensometer as defined in Practice E 83.

NOTE 3—The requirements for extensometers cited herein apply to compressometers as well.

5.3 *Compression Tool*—A compression tool for applying the load to the test specimen. This tool shall be so constructed that loading is axial within 1:1000 and applied through surfaces that are flat within 0.025 mm (0.001 in.) and parallel to each other in a plane normal to the vertical loading axis. Examples of suitable compression tools are shown in Fig. 1 and Fig. 2.

5.4 *Supporting Jig*—A supporting jig for thin specimens is shown in Fig. 3 and Fig. 4.

5.5 *Micrometers*—Suitable micrometers, reading to 0.01 mm or 0.001 in. for measuring the width, thickness, and length of the specimens.

6. Test Specimens

6.1 Unless otherwise specified in the materials specifications, the specimens described in 6.2 and 6.7 shall be used. These specimens may be prepared by machining operations from materials in sheet, plate, rod, tube, or similar form, or they may be prepared by compression or injection molding of the material to be tested. All machining operations shall be done carefully so that smooth surfaces result. Great care shall be taken in machining the ends so that smooth, flat parallel surfaces and sharp, clean edges, to within 0.025 mm (0.001 in.) perpendicular to the long axis of the specimen, result.

6.2 The standard test specimen, except as indicated in 6.3-6.7, shall be in the form of a right cylinder or prism whose length is twice its principal width or diameter. Preferred specimen sizes are 12.7 by 12.7 by 25.4 mm (0.50 by 0.50 by 1 in.) (prism), or 12.7 mm in diameter by 25.4 mm (cylinder). Where elastic modulus and offset yield-stress data are desired, the test specimen shall be of such dimensions that the slenderness ratio is in the range from 11 to 16:1. In this case, preferred specimen sizes are 12.7 by 12.7 by 50.8 mm (0.50 by 0.50 by

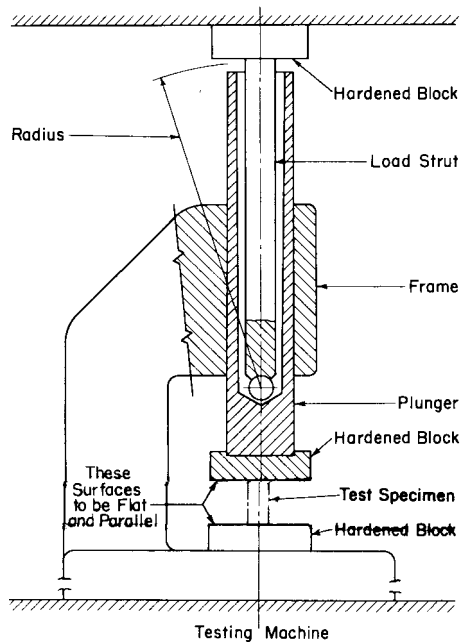

NOTE 1—Devices similar to the one illustrated have been successfully used in a number of different laboratories. Details of the device developed at the National Institute for Standards and Technology are given in the paper by Aitchinson, C. S., and Miller, J. A., "A Subpress for Compressive Tests," National Advisory Committee for Aeronautics, Technical Note No. 912, 1943.

FIG. 1 Subpress for Compression Tests

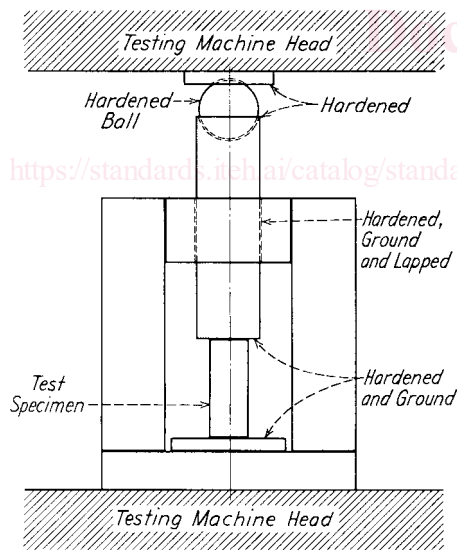

FIG. 2 Compression Tool

2 in.) (prism), or 12.7 mm in diameter by 50.8 mm (cylinder).
 6.3 For rod material, the test specimen shall have a diameter equal to the diameter of the rod and a sufficient length to allow a specimen slenderness ratio in the range from 11 to 16:1.

6.4 When testing tubes, the test specimen shall have a diameter equal to the diameter of the tube and a length of 25.4 mm (1 in.) (Note 4). For crushing-load determinations (at right angles to the longitudinal axis), the specimen size shall be the same, with the diameter becoming the height.

NOTE 4—This specimen can be used for tubes with a wall thickness of

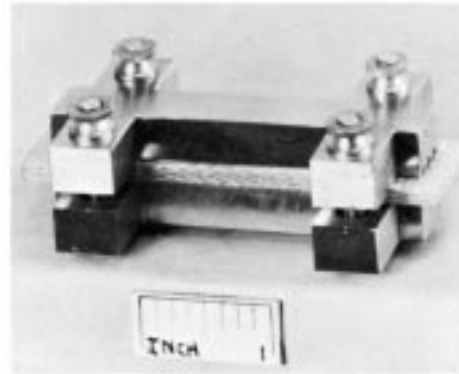

FIG. 3 Support Jig for This Specimen

1 mm (0.039 in.) or over, to inside diameters of 6.4 mm (0.25 in.) or over, and to outside diameters of 50.8 mm (2.0 in.) or less.

6.5 Where it is desired to test conventional high-pressure laminates in the form of sheets, the thickness of which is less than 25.4 mm (1 in.), a pile-up of sheets 25.4 mm square, with a sufficient number of layers to produce a height of at least 25.4 mm, may be used.

6.6 When testing material that may be suspected of anisotropy, duplicate sets of test specimens shall be prepared having their long axis respectively parallel with and normal to the suspected direction of anisotropy.

6.7 Reinforced Plastics, Including High-Strength Composites and High-Strength Composites and Highly Orthotropic Laminates—The following specimens shall be used for reinforced materials, or for other materials when necessary to comply with the slenderness ratio requirements or to permit attachment of a deformation-measuring device.

6.7.1 For materials 3.2 mm (1/8 in.) and over in thickness, a specimen shall consist of a prism having a cross section of 12.7 mm (1/2 in.) by the thickness of the material and a length such that the slenderness ratio is in the range from 11 to 16:1 (Note 5).

6.7.2 For materials under 3.2 mm (1/8 in.) thick, or where elastic modulus testing is required and the slenderness ratio does not provide for enough length for attachment of a compressometer or similar device, a specimen conforming to that shown in Fig. 5 shall be used. The supporting jig shown in Fig. 3 and Fig. 4 shall be used to support the specimen during testing (Note 6).

NOTE 5—If failure for materials in the thickness range of 3.2 mm (1/8 in.) is by delamination rather than by the desirable shear plane fracture, the material may be tested in accordance with 6.7.2.

NOTE 6—Round-robin tests have established that relatively satisfactory measurements of modulus of elasticity may be obtained by applying a compressometer to the edges of the jig-supported specimen.

6.8 When testing syntactic foam, the standard test specimen shall be in the form of a right cylinder 25.4 mm (1 in.) in diameter by 50.8 mm (2 in.) in length.

7. Conditioning

7.1 Conditioning—Condition the test specimens at 23 ± 2°C (73.4 ± 3.6°F) and 50 ± 5 % relative humidity for not less than 40 h prior to testing in accordance with Procedure A of