



## Standard Test Method for Tensile Properties of Plastics<sup>1</sup>

This standard is issued under the fixed designation D 638; the number immediately following the designation indicates the year of original adoption or, in the case of revision, the year of last revision. A number in parentheses indicates the year of last reapproval. A superscript epsilon ( $\epsilon$ ) indicates an editorial change since the last revision or reapproval.

*This standard has been approved for use by agencies of the Department of Defense.*

### 1. Scope \*

1.1 This test method covers the determination of the tensile properties of unreinforced and reinforced plastics in the form of standard dumbbell-shaped test specimens when tested under defined conditions of pretreatment, temperature, humidity, and testing machine speed.

1.2 This test method can be used for testing materials of any thickness up to 14 mm (0.55 in.). However, for testing specimens in the form of thin sheeting, including film less than 1.0 mm (0.04 in.) in thickness, Test Methods D 882 is the preferred test method. Materials with a thickness greater than 14 mm (0.55 in.) must be reduced by machining.

1.3 This test method includes the option of determining Poisson's ratio at room temperature.

NOTE 1—This test method and ISO 527-1 are technically equivalent.

NOTE 2—This test method is not intended to cover precise physical procedures. It is recognized that the constant rate of crosshead movement type of test leaves much to be desired from a theoretical standpoint, that wide differences may exist between rate of crosshead movement and rate of strain between gage marks on the specimen, and that the testing speeds specified disguise important effects characteristic of materials in the plastic state. Further, it is realized that variations in the thicknesses of test specimens, which are permitted by these procedures, produce variations in the surface-volume ratios of such specimens, and that these variations may influence the test results. Hence, where directly comparable results are desired, all samples should be of equal thickness. Special additional tests should be used where more precise physical data are needed.

NOTE 3—This test method may be used for testing phenolic molded resin or laminated materials. However, where these materials are used as electrical insulation, such materials should be tested in accordance with Test Methods D 229 and Test Method D 651.

NOTE 4—For tensile properties of resin-matrix composites reinforced with oriented continuous or discontinuous high modulus  $>20$ -GPa ( $>3.0 \times 10^6$ -psi) fibers, tests shall be made in accordance with Test Method D 3039/D 3039M.

1.4 Test data obtained by this test method are relevant and appropriate for use in engineering design.

1.5 The values stated in SI units are to be regarded as the standard. The values given in parentheses are for information only.

1.6 *This standard does not purport to address all of the*

*safety concerns, if any, associated with its use. It is the responsibility of the user of this standard to establish appropriate safety and health practices and determine the applicability of regulatory limitations prior to use.*

### 2. Referenced Documents

#### 2.1 ASTM Standards:

- D 229 Test Methods for Rigid Sheet and Plate Materials Used for Electrical Insulation<sup>2</sup>
- D 412 Test Methods for Vulcanized Rubber and Thermoplastic Elastomers—Tension<sup>3</sup>
- D 618 Practice for Conditioning Plastics for Testing<sup>4</sup>
- D 651 Test Method for Tensile Strength of Molded Electrical Insulating Materials<sup>5</sup>
- D 882 Test Methods for Tensile Properties of Thin Plastic Sheeting<sup>4</sup>
- D 883 Terminology Relating to Plastics<sup>4</sup>
- D 1822 Test Method for Tensile-Impact Energy to Break Plastics and Electrical Insulating Materials<sup>4</sup>
- D 3039/D 3039M Test Method for Tensile Properties of Polymer Matrix Composite Materials<sup>6</sup>
- D 4000 Classification System for Specifying Plastic Materials<sup>7</sup>
- D 4066 Specification for Nylon Injection and Extrusion Materials<sup>7</sup>
- D 5947 Test Methods for Physical Dimensions of Solid Plastic Specimens<sup>8</sup>
- E 4 Practices for Force Verification of Testing Machines<sup>9</sup>
- E 83 Practice for Verification and Classification of Extensometer Systems<sup>9</sup>
- E 132 Test Method for Poisson's Ratio at Room Temperature<sup>9</sup>
- E 691 Practice for Conducting an Interlaboratory Study to Determine the Precision of a Test Method<sup>10</sup>

#### 2.2 ISO Standard:

<sup>2</sup> Annual Book of ASTM Standards, Vol 10.01.

<sup>3</sup> Annual Book of ASTM Standards, Vol 09.01.

<sup>4</sup> Annual Book of ASTM Standards, Vol 08.01.

<sup>5</sup> Discontinued; see 1994 Annual Book of ASTM Standards, Vol 10.01.

<sup>6</sup> Annual Book of ASTM Standards, Vol 15.03.

<sup>7</sup> Annual Book of ASTM Standards, Vol 08.02.

<sup>8</sup> Annual Book of ASTM Standards, Vol 08.03.

<sup>9</sup> Annual Book of ASTM Standards, Vol 03.01.

<sup>10</sup> Annual Book of ASTM Standards, Vol 14.02.

<sup>1</sup> This test method is under the jurisdiction of ASTM Committee D20 on Plastics and is the direct responsibility of Subcommittee D 20.10 on Mechanical Properties. Current edition approved Dec. 10, 2000. Published February 2001. Originally published as D 638 – 41 T. Last previous edition D 638 – 99.

\*A Summary of Changes section appears at the end of this standard.

ISO 527-1 Determination of Tensile Properties<sup>11</sup>

### 3. Terminology

3.1 *Definitions*—Definitions of terms applying to this test method appear in Terminology D 883 and Annex A2.

### 4. Significance and Use

4.1 This test method is designed to produce tensile property data for the control and specification of plastic materials. These data are also useful for qualitative characterization and for research and development. For many materials, there may be a specification that requires the use of this test method, but with some procedural modifications that take precedence when adhering to the specification. Therefore, it is advisable to refer to that material specification before using this test method. Table 1 in Classification D 4000 lists the ASTM materials standards that currently exist.

4.2 Tensile properties may vary with specimen preparation and with speed and environment of testing. Consequently, where precise comparative results are desired, these factors must be carefully controlled.

4.2.1 It is realized that a material cannot be tested without also testing the method of preparation of that material. Hence, when comparative tests of materials per se are desired, the greatest care must be exercised to ensure that all samples are prepared in exactly the same way, unless the test is to include the effects of sample preparation. Similarly, for referee purposes or comparisons within any given series of specimens, care must be taken to secure the maximum degree of uniformity in details of preparation, treatment, and handling.

4.3 Tensile properties may provide useful data for plastics engineering design purposes. However, because of the high degree of sensitivity exhibited by many plastics to rate of straining and environmental conditions, data obtained by this test method cannot be considered valid for applications involving load-time scales or environments widely different from those of this test method. In cases of such dissimilarity, no reliable estimation of the limit of usefulness can be made for most plastics. This sensitivity to rate of straining and environment necessitates testing over a broad load-time scale (including impact and creep) and range of environmental conditions if tensile properties are to suffice for engineering design purposes.

NOTE 5—Since the existence of a true elastic limit in plastics (as in many other organic materials and in many metals) is debatable, the propriety of applying the term “elastic modulus” in its quoted, generally accepted definition to describe the “stiffness” or “rigidity” of a plastic has been seriously questioned. The exact stress-strain characteristics of plastic materials are highly dependent on such factors as rate of application of stress, temperature, previous history of specimen, etc. However, stress-strain curves for plastics, determined as described in this test method, almost always show a linear region at low stresses, and a straight line drawn tangent to this portion of the curve permits calculation of an elastic modulus of the usually defined type. Such a constant is useful if its arbitrary nature and dependence on time, temperature, and similar factors are realized.

4.4 *Poisson’s Ratio*—When uniaxial tensile force is applied to a solid, the solid stretches in the direction of the applied force (axially), but it also contracts in both dimensions lateral to the applied force. If the solid is homogeneous and isotropic, and the material remains elastic under the action of the applied force, the lateral strain bears a constant relationship to the axial strain. This constant, called Poisson’s ratio, is defined as the negative ratio of the transverse (negative) to axial strain under uniaxial stress.

4.4.1 Poisson’s ratio is used for the design of structures in which all dimensional changes resulting from the application of force need to be taken into account and in the application of the generalized theory of elasticity to structural analysis.

NOTE 6—The accuracy of the determination of Poisson’s ratio is usually limited by the accuracy of the transverse strain measurements because the percentage errors in these measurements are usually greater than in the axial strain measurements. Since a ratio rather than an absolute quantity is measured, it is only necessary to know accurately the relative value of the calibration factors of the extensometers. Also, in general, the value of the applied loads need not be known accurately.

### 5. Apparatus

5.1 *Testing Machine*—A testing machine of the constant-rate-of-crosshead-movement type and comprising essentially the following:

5.1.1 *Fixed Member*—A fixed or essentially stationary member carrying one grip.

5.1.2 *Movable Member*—A movable member carrying a second grip.

5.1.3 *Grips*—Grips for holding the test specimen between the fixed member and the movable member of the testing machine can be either the fixed or self-aligning type.

5.1.3.1 Fixed grips are rigidly attached to the fixed and movable members of the testing machine. When this type of grip is used extreme care should be taken to ensure that the test specimen is inserted and clamped so that the long axis of the test specimen coincides with the direction of pull through the center line of the grip assembly.

5.1.3.2 Self-aligning grips are attached to the fixed and movable members of the testing machine in such a manner that they will move freely into alignment as soon as any load is applied so that the long axis of the test specimen will coincide with the direction of the applied pull through the center line of the grip assembly. The specimens should be aligned as perfectly as possible with the direction of pull so that no rotary motion that may induce slippage will occur in the grips; there is a limit to the amount of misalignment self-aligning grips will accommodate.

5.1.3.3 The test specimen shall be held in such a way that slippage relative to the grips is prevented insofar as possible. Grip surfaces that are deeply scored or serrated with a pattern similar to those of a coarse single-cut file, serrations about 2.4 mm (0.09 in.) apart and about 1.6 mm (0.06 in.) deep, have been found satisfactory for most thermoplastics. Finer serrations have been found to be more satisfactory for harder plastics, such as the thermosetting materials. The serrations should be kept clean and sharp. Breaking in the grips may occur at times, even when deep serrations or abraded specimen surfaces are used; other techniques must be used in these cases.

<sup>11</sup> Available from American National Standards Institute, 11 W. 42nd St., 13th Floor, New York, NY 10036.

Other techniques that have been found useful, particularly with smooth-faced grips, are abrading that portion of the surface of the specimen that will be in the grips, and interposing thin pieces of abrasive cloth, abrasive paper, or plastic, or rubber-coated fabric, commonly called hospital sheeting, between the specimen and the grip surface. No. 80 double-sided abrasive paper has been found effective in many cases. An open-mesh fabric, in which the threads are coated with abrasive, has also been effective. Reducing the cross-sectional area of the specimen may also be effective. The use of special types of grips is sometimes necessary to eliminate slippage and breakage in the grips.

**5.1.4 Drive Mechanism**—A drive mechanism for imparting to the movable member a uniform, controlled velocity with respect to the stationary member, with this velocity to be regulated as specified in Section 8.

**5.1.5 Load Indicator**—A suitable load-indicating mechanism capable of showing the total tensile load carried by the test specimen when held by the grips. This mechanism shall be essentially free of inertia lag at the specified rate of testing and shall indicate the load with an accuracy of  $\pm 1\%$  of the indicated value, or better. The accuracy of the testing machine shall be verified in accordance with Practices E 4.

**NOTE 7**—Experience has shown that many testing machines now in use are incapable of maintaining accuracy for as long as the periods between inspection recommended in Practices E 4. Hence, it is recommended that each machine be studied individually and verified as often as may be found necessary. It frequently will be necessary to perform this function daily.

**5.1.6** The fixed member, movable member, drive mechanism, and grips shall be constructed of such materials and in such proportions that the total elastic longitudinal strain of the system constituted by these parts does not exceed 1 % of the total longitudinal strain between the two gage marks on the test specimen at any time during the test and at any load up to the rated capacity of the machine.

**5.2 Extension Indicator (extensometer)**—A suitable instrument shall be used for determining the distance between two designated points within the gage length of the test specimen as the specimen is stretched. For referee purposes, the extensometer must be set at the full gage length of the specimen, as shown in Fig. 1. It is desirable, but not essential, that this instrument automatically record this distance, or any change in it, as a function of the load on the test specimen or of the elapsed time from the start of the test, or both. If only the latter is obtained, load-time data must also be taken. This instrument shall be essentially free of inertia at the specified speed of testing. Extensometers shall be classified and their calibration periodically verified in accordance with Practice E 83.

**5.2.1 Modulus-of-Elasticity Measurements**—For modulus-of-elasticity measurements, an extensometer with a maximum strain error of 0.0002 mm/mm (in./in.) that automatically and continuously records shall be used. An extensometer classified by Practice E 83 as fulfilling the requirements of a B-2 classification within the range of use for modulus measurements meets this requirement.

**5.2.2 Low-Extension Measurements**—For elongation-at-yield and low-extension measurements (nominally 20 % or

less), the same above extensometer, attenuated to 20 % extension, may be used. In any case, the extensometer system must meet at least Class C (Practice E 83) requirements, which include a fixed strain error of 0.001 strain or  $\pm 1.0\%$  of the indicated strain, whichever is greater.

**5.2.3 High-Extension Measurements**—For making measurements at elongations greater than 20 %, measuring techniques with error no greater than  $\pm 10\%$  of the measured value are acceptable.

**5.2.4 Poisson's Ratio**—Bi-axial extensometer or axial and transverse extensometers capable of recording axial strain and transverse strain simultaneously. The extensometers shall be capable of measuring the change in strains with an accuracy of 1 % of the relevant value or better.

**NOTE 8**—Strain gages can be used as an alternative method to measure axial and transverse strain; however, proper techniques for mounting strain gages are crucial to obtaining accurate data. Consult strain gage suppliers for instruction and training in these special techniques.

**5.3 Micrometers**—Suitable micrometers for measuring the width and thickness of the test specimen to an incremental discrimination of at least 0.025 mm (0.001 in.) should be used. All width and thickness measurements of rigid and semirigid plastics may be measured with a hand micrometer with ratchet. A suitable instrument for measuring the thickness of nonrigid test specimens shall have: (1) a contact measuring pressure of  $25 \pm 2.5$  kPa ( $3.6 \pm 0.36$  psi), (2) a movable circular contact foot  $6.35 \pm 0.025$  mm ( $0.250 \pm 0.001$  in.) in diameter, and (3) a lower fixed anvil large enough to extend beyond the contact foot in all directions and being parallel to the contact foot within 0.005 mm (0.0002 in.) over the entire foot area. Flatness of the foot and anvil shall conform to Test Method D 5947.

**5.3.1** An optional instrument equipped with a circular contact foot  $15.88 \pm 0.08$  mm ( $0.625 \pm 0.003$  in.) in diameter is recommended for thickness measuring of process samples or larger specimens at least 15.88 mm in minimum width.

## 6. Test Specimens

### 6.1 Sheet, Plate, and Molded Plastics:

**6.1.1 Rigid and Semirigid Plastics**—The test specimen shall conform to the dimensions shown in Fig. 1. The Type I specimen is the preferred specimen and shall be used where sufficient material having a thickness of 7 mm (0.28 in.) or less is available. The Type II specimen may be used when a material does not break in the narrow section with the preferred Type I specimen. The Type V specimen shall be used where only limited material having a thickness of 4 mm (0.16 in.) or less is available for evaluation, or where a large number of specimens are to be exposed in a limited space (thermal and environmental stability tests, etc.). The Type IV specimen should be used when direct comparisons are required between materials in different rigidity cases (that is, nonrigid and semirigid). The Type III specimen must be used for all materials with a thickness of greater than 7 mm (0.28 in.) but not more than 14 mm (0.55 in.).

**6.1.2 Nonrigid Plastics**—The test specimen shall conform to the dimensions shown in Fig. 1. The Type IV specimen shall be used for testing nonrigid plastics with a thickness of 4 mm (0.16 in.) or less. The Type III specimen must be used for all materials with a thickness greater than 7 mm (0.28 in.) but not

ASTM D 638

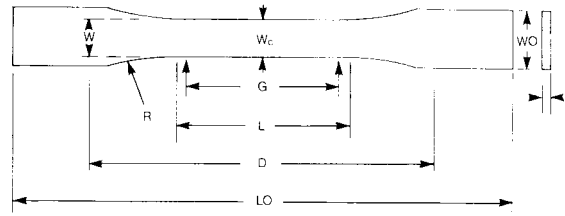

TYPES I, II, III & IV

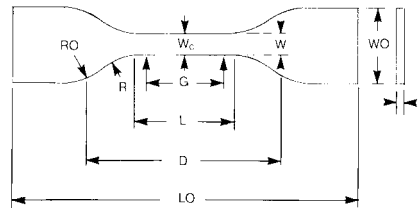

TYPE IV

Specimen Dimensions for Thickness,  $T$ , mm (in.)<sup>A</sup>

Dimensions (see drawings)	7 (0.28) or under		Over 7 to 14 (0.28 to 0.55), incl		4 (0.16) or under		Tolerances
	Type I	Type II	Type III	Type IV <sup>B</sup>	Type V <sup>C,D</sup>		
$W$ —Width of narrow section <sup>E,F</sup>	13 (0.50)	6 (0.25)	19 (0.75)	6 (0.25)	3.18 (0.125)	$\pm 0.5 (\pm 0.02)^{B,C}$	
$L$ —Length of narrow section	57 (2.25)	57 (2.25)	57 (2.25)	33 (1.30)	9.53 (0.375)	$\pm 0.5 (\pm 0.02)^C$	
$WO$ —Width overall, min <sup>G</sup>	19 (0.75)	19 (0.75)	29 (1.13)	19 (0.75)	...	+ 6.4 (+ 0.25)	
$WO$ —Width overall, min <sup>G</sup>	...	...	...	...	9.53 (0.375)	+ 3.18 (+ 0.125)	
$LO$ —Length overall, min <sup>H</sup>	165 (6.5)	183 (7.2)	246 (9.7)	115 (4.5)	63.5 (2.5)	no max (no max)	
$G$ —Gage length <sup>I</sup>	50 (2.00)	50 (2.00)	50 (2.00)	...	7.62 (0.300)	$\pm 0.25 (\pm 0.010)^C$	
$G$ —Gage length <sup>I</sup>	...	...	...	25 (1.00)	...	$\pm 0.13 (\pm 0.005)$	
$D$ —Distance between grips	115 (4.5)	135 (5.3)	115 (4.5)	65 (2.5) <sup>J</sup>	25.4 (1.0)	$\pm 5 (\pm 0.2)$	
$R$ —Radius of fillet	76 (3.00)	76 (3.00)	76 (3.00)	14 (0.56)	12.7 (0.5)	$\pm 1 (\pm 0.04)^C$	
$RO$ —Outer radius (Type IV)	...	...	...	25 (1.00)	...	$\pm 1 (\pm 0.04)$	

<sup>A</sup> Thickness,  $T$ , shall be  $3.2 \pm 0.4$  mm ( $0.13 \pm 0.02$  in.) for all types of molded specimens, and for other Types I and II specimens where possible. If specimens are machined from sheets or plates, thickness,  $T$ , may be the thickness of the sheet or plate provided this does not exceed the range stated for the intended specimen type. For sheets of nominal thickness greater than 14 mm (0.55 in.) the specimens shall be machined to  $14 \pm 0.4$  mm ( $0.55 \pm 0.02$  in.) in thickness, for use with the Type III specimen. For sheets of nominal thickness between 14 and 51 mm (0.55 and 2 in.) approximately equal amounts shall be machined from each surface. For thicker sheets both surfaces of the specimen shall be machined, and the location of the specimen with reference to the original thickness of the sheet shall be noted. Tolerances on thickness less than 14 mm (0.55 in.) shall be those standard for the grade of material tested.

<sup>B</sup> For the Type IV specimen, the internal width of the narrow section of the die shall be  $6.00 \pm 0.05$  mm ( $0.250 \pm 0.002$  in.). The dimensions are essentially those of Die C in Test Methods D 412.

<sup>C</sup> The Type V specimen shall be machined or die cut to the dimensions shown, or molded in a mold whose cavity has these dimensions. The dimensions shall be:

- $W = 3.18 \pm 0.03$  mm ( $0.125 \pm 0.001$  in.),
- $L = 9.53 \pm 0.08$  mm ( $0.375 \pm 0.003$  in.),
- $G = 7.62 \pm 0.02$  mm ( $0.300 \pm 0.001$  in.), and
- $R = 12.7 \pm 0.08$  mm ( $0.500 \pm 0.003$  in.).

The other tolerances are those in the table.

<sup>D</sup> Supporting data on the introduction of the L specimen of Test Method D 1822 as the Type V specimen are available from ASTM Headquarters. Request RR:D20-1038.

<sup>E</sup> The width at the center  $W_c$  shall be  $+0.00$  mm,  $-0.10$  mm ( $+0.000$  in.,  $-0.004$  in.) compared with width  $W$  at other parts of the reduced section. Any reduction in  $W$  at the center shall be gradual, equally on each side so that no abrupt changes in dimension result.

<sup>F</sup> For molded specimens, a draft of not over 0.13 mm (0.005 in.) may be allowed for either Type I or II specimens 3.2 mm (0.13 in.) in thickness, and this should be taken into account when calculating width of the specimen. Thus a typical section of a molded Type I specimen, having the maximum allowable draft, could be as follows:

<sup>G</sup> Overall widths greater than the minimum indicated may be desirable for some materials in order to avoid breaking in the grips.

<sup>H</sup> Overall lengths greater than the minimum indicated may be desirable either to avoid breaking in the grips or to satisfy special test requirements.

<sup>I</sup> Test marks or initial extensometer span.

<sup>J</sup> When self-tightening grips are used, for highly extensible polymers, the distance between grips will depend upon the types of grips used and may not be critical if maintained uniform once chosen.

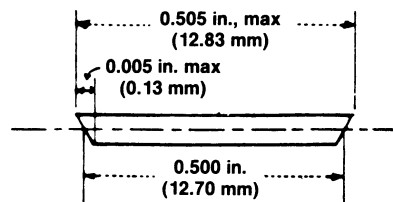

FIG. 1 Tension Test Specimens for Sheet, Plate, and Molded Plastics

more than 14 mm (0.55 in.).

6.1.3 Reinforced Composites—The test specimen for reinforced composites, including highly orthotropic laminates,

shall conform to the dimensions of the Type I specimen shown in Fig. 1.

6.1.4 Preparation—Test specimens shall be prepared by

machining operations, or die cutting, from materials in sheet, plate, slab, or similar form. Materials thicker than 14 mm (0.55 in.) must be machined to 14 mm (0.55 in.) for use as Type III specimens. Specimens can also be prepared by molding the material to be tested.

NOTE 9—Test results have shown that for some materials such as glass cloth, SMC, and BMC laminates, other specimen types should be considered to ensure breakage within the gage length of the specimen, as mandated by 7.3.

NOTE 10—When preparing specimens from certain composite laminates such as woven roving, or glass cloth, care must be exercised in cutting the specimens parallel to the reinforcement. The reinforcement will be significantly weakened by cutting on a bias, resulting in lower laminate properties, unless testing of specimens in a direction other than parallel with the reinforcement constitutes a variable being studied.

NOTE 11—Specimens prepared by injection molding may have different tensile properties than specimens prepared by machining or die-cutting because of the orientation induced. This effect may be more pronounced in specimens with narrow sections.

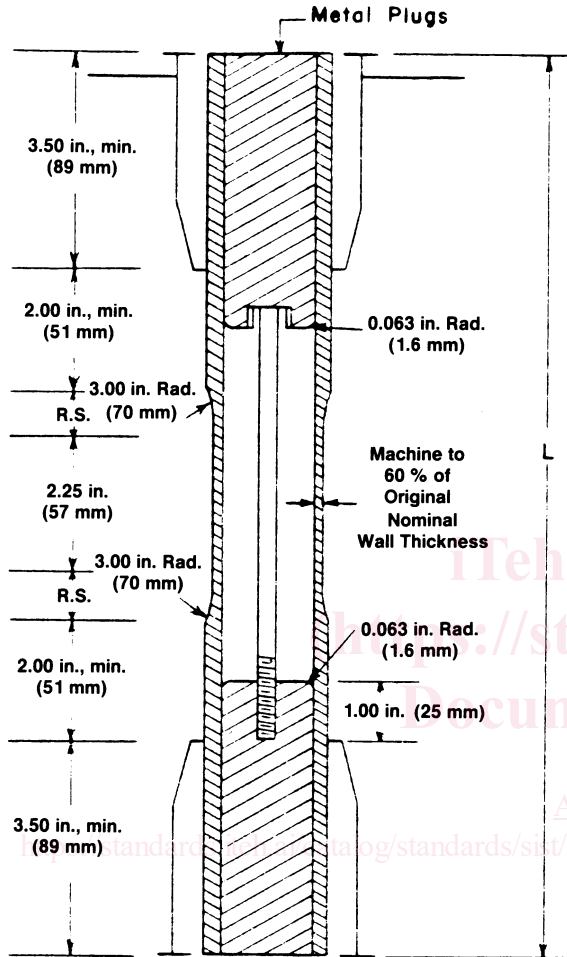

DIMENSIONS OF TUBE SPECIMENS

Nominal Wall Thickness	Length of Radial Sections, 2R.S.	Total Calculated Minimum Length of Specimen	Standard Length, L, of Specimen to Be Used for 89-mm (3.5-in.) Jaws <sup>A</sup>
			mm (in.)
0.79 (1/32)	13.9 (0.547)	350 (13.80)	381 (15)
1.2 (3/64)	17.0 (0.670)	354 (13.92)	381 (15)
1.6 (1/16)	19.6 (0.773)	356 (14.02)	381 (15)
2.4 (3/32)	24.0 (0.946)	361 (14.20)	381 (15)
3.2 (1/8)	27.7 (1.091)	364 (14.34)	381 (15)
4.8 (3/16)	33.9 (1.333)	370 (14.58)	381 (15)
6.4 (1/4)	39.0 (1.536)	376 (14.79)	400 (15.75)
7.9 (5/16)	43.5 (1.714)	380 (14.96)	400 (15.75)
9.5 (3/8)	47.6 (1.873)	384 (15.12)	400 (15.75)
11.1 (7/16)	51.3 (2.019)	388 (15.27)	400 (15.75)
12.7 (1/2)	54.7 (2.154)	391 (15.40)	419 (16.5)

<sup>A</sup> For other jaws greater than 89 mm (3.5 in.), the standard length shall be increased by twice the length of the jaws minus 178 mm (7 in.). The standard length permits a slippage of approximately 6.4 to 12.7 mm (0.25 to 0.50 in.) in each jaw while maintaining the maximum length of the jaw grip.

FIG. 2 Diagram Showing Location of Tube Tension Test Specimens in Testing Machine

6.2 *Rigid Tubes*—The test specimen for rigid tubes shall be as shown in Fig. 2. The length, *L*, shall be as shown in the table in Fig. 2. A groove shall be machined around the outside of the specimen at the center of its length so that the wall section after machining shall be 60 % of the original nominal wall thickness. This groove shall consist of a straight section 57.2 mm (2.25 in.) in length with a radius of 76 mm (3 in.) at each end joining it to the outside diameter. Steel or brass plugs having diameters such that they will fit snugly inside the tube and having a length equal to the full jaw length plus 25 mm (1 in.) shall be placed in the ends of the specimens to prevent crushing. They can be located conveniently in the tube by separating and supporting them on a threaded metal rod. Details of plugs and test assembly are shown in Fig. 2.

6.3 *Rigid Rods*—The test specimen for rigid rods shall be as shown in Fig. 3. The length, *L*, shall be as shown in the table in Fig. 3. A groove shall be machined around the specimen at the center of its length so that the diameter of the machined portion shall be 60 % of the original nominal diameter. This groove shall consist of a straight section 57.2 mm (2.25 in.) in length with a radius of 76 mm (3 in.) at each end joining it to the outside diameter.

6.4 All surfaces of the specimen shall be free of visible flaws, scratches, or imperfections. Marks left by coarse machining operations shall be carefully removed with a fine file or abrasive, and the filed surfaces shall then be smoothed with abrasive paper (No. 00 or finer). The finishing sanding strokes shall be made in a direction parallel to the long axis of the test specimen. All flash shall be removed from a molded specimen, taking great care not to disturb the molded surfaces. In machining a specimen, undercuts that would exceed the dimensional tolerances shown in Fig. 1 shall be scrupulously avoided. Care shall also be taken to avoid other common machining errors.

6.5 If it is necessary to place gage marks on the specimen, this shall be done with a wax crayon or India ink that will not affect the material being tested. Gage marks shall not be scratched, punched, or impressed on the specimen.

6.6 When testing materials that are suspected of anisotropy, duplicate sets of test specimens shall be prepared, having their long axes respectively parallel with, and normal to, the suspected direction of anisotropy.

## 7. Number of Test Specimens

7.1 Test at least five specimens for each sample in the case of isotropic materials.

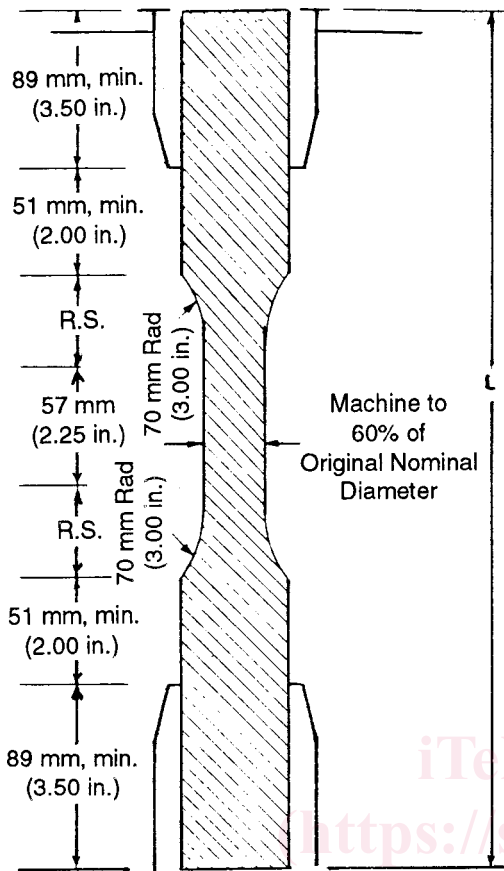

DIMENSIONS OF ROD SPECIMENS

Nominal Diameter	Length of Radial Sections, 2R.S.	Total Calculated Minimum Length of Specimen	Standard Length, L, of Specimen to Be Used for 89-mm (3½-in.) Jaws <sup>A</sup>
mm (in.)			
3.2 (1/8)	19.6 (0.773)	356 (14.02)	381 (15)
4.7 (1/4)	24.0 (0.946)	361 (14.20)	381 (15)
6.4 (1/4)	27.7 (1.091)	364 (14.34)	381 (15)
9.5 (3/8)	33.9 (1.333)	370 (14.58)	381 (15)
12.7 (1/2)	39.0 (1.536)	376 (14.79)	400 (15.75)
15.9 (5/8)	43.5 (1.714)	380 (14.96)	400 (15.75)
19.0 (3/4)	47.6 (1.873)	384 (15.12)	400 (15.75)
22.2 (7/8)	51.5 (2.019)	388 (15.27)	400 (15.75)
25.4 (1)	54.7 (2.154)	391 (15.40)	419 (16.5)
31.8 (1¼)	60.9 (2.398)	398 (15.65)	419 (16.5)
38.1 (1½)	66.4 (2.615)	403 (15.87)	419 (16.5)
42.5 (1¾)	71.4 (2.812)	408 (16.06)	419 (16.5)
50.8 (2)	76.0 (2.993)	412 (16.24)	432 (17)

<sup>A</sup> For other jaws greater than 89 mm (3.5 in.), the standard length shall be increased by twice the length of the jaws minus 178 mm (7 in.). The standard length permits a slippage of approximately 6.4 to 12.7 mm (0.25 to 0.50 in.) in each jaw while maintaining the maximum length of the jaw grip.

FIG. 3 Diagram Showing Location of Rod Tension Test Specimen in Testing Machine

7.2 Test ten specimens, five normal to, and five parallel with, the principle axis of anisotropy, for each sample in the case of anisotropic materials.

7.3 Discard specimens that break at some obvious fortuitous flaw, or that do not break between the predetermined gage length and in the fillets, and make retests, unless such flaws constitute a variable to be studied.

NOTE 12—Before testing, all transparent specimens should be inspected in a polariscope. Those which show atypical or concentrated strain patterns should be rejected, unless the effects of these residual strains constitute a variable to be studied.

### 8. Speed of Testing

8.1 Speed of testing shall be the relative rate of motion of the grips or test fixtures during the test. The rate of motion of the driven grip or fixture when the testing machine is running idle may be used, if it can be shown that the resulting speed of testing is within the limits of variation allowed.

8.2 Choose the speed of testing from Table 1. Determine this chosen speed of testing by the specification for the material being tested, or by agreement between those concerned. When the speed is not specified, use the lowest speed shown in Table 1 for the specimen geometry being used, which gives rupture within ½ to 5-min testing time.

8.3 Modulus determinations may be made at the speed selected for the other tensile properties when the recorder response and resolution are adequate.

8.4 Poisson's ratio determinations shall be made at the same speed selected for modulus determinations.

### 9. Conditioning

9.1 *Conditioning*—Condition the test specimens at 23 ± 2°C (73.4 ± 3.6°F) and 50 ± 5 % relative humidity for not less than 40 h prior to test in accordance with Procedure A of Practice D 618, for those tests where conditioning is required. In cases of disagreement, the tolerances shall be ± 1°C (1.8°F) and ± 2 % relative humidity.

9.1.1 Note that for some hygroscopic materials, such as nylons, the material specifications (for example, Specification D 4066) call for testing "dry as-molded specimens." Such requirements take precedence over the above routine preconditioning to 50 % relative humidity and require sealing the specimens in water vapor-impermeable containers as soon as molded and not removing them until ready for testing.

TABLE 1 Designations for Speed of Testing<sup>A</sup>

Classification <sup>B</sup>	Specimen Type	Speed of Testing, mm/min (in./min)	Nominal Strain <sup>C</sup> Rate at Start of Test, mm/mm·min (in./in·min)
Rigid and Semirigid	I, II, III rods and tubes	5 (0.2) ± 25 %	0.1
		50 (2) ± 10 %	1
	IV	500 (20) ± 10 %	10
		5 (0.2) ± 25 %	0.15
		50 (2) ± 10 %	1.5
Nonrigid	V	500 (20) ± 10 %	15
		1 (0.05) ± 25 %	0.1
	III	10 (0.5) ± 25 %	1
		100 (5) ± 25 %	10
		50 (2) ± 10 %	1
IV	500 (20) ± 10 %	10	
	50 (2) ± 10 %	1.5	
	500 (20) ± 10 %	15	

<sup>A</sup> Select the lowest speed that produces rupture in ½ to 5 min for the specimen geometry being used (see 8.2).

<sup>B</sup> See Terminology D 883 for definitions.

<sup>C</sup> The initial rate of straining cannot be calculated exactly for dumbbell-shaped specimens because of extension, both in the reduced section outside the gage length and in the fillets. This initial strain rate can be measured from the initial slope of the tensile strain-versus-time diagram.