INTERNATIONAL STANDARD 1724

INTERNATIONAL ORGANIZATION FOR STANDARDIZATION • МЕЖДУНАРОДНАЯ ОРГАНИЗАЦИЯ ПО СТАНДАРТИЗАЦИИ • ORGANISATION INTERNATIONALE DE NORMALISATION

Road vehicles — Electrical connections between towing vehicles and towed vehicles with 6 or 12 V electrical equipment — Type 12 N (normal)

Véhicules routiers — Liaisons électriques entre véhicules tracteurs et véhicules remorqués avec équipement électrique 6 ou 12 V — Type 12 N (normal)

First edition — 1975-11-01

UDC 629.1.013.5 : 621.-42/-43

Ref. No. ISO 1724-1975 (E)

Descriptors : road vehicles, tractors, towed road vehicles, electric connectors, 12 volts, specifications, colour marking, trailers.

Price based on 4 pages

FOREWORD

ISO (the International Organization for Standardization) is a worldwide federation of national standards institutes (ISO Member Bodies). The work of developing International Standards is carried out through ISO Technical Committees. Every Member Body interested in a subject for which a Technical Committee has been set up has the right to be represented on that Committee. International organizations, governmental and non-governmental, in liaison with ISO, also take part in the work.

Draft International Standards adopted by the Technical Committees are circulated to the Member Bodies for approval before their acceptance as International Standards by the ISO Council.

International Standard ISO 1724 was drawn up by Technical Committee ISO/TC 22, *Road vehicles*, and circulated to the Member Bodies in November 1974.

It has been approved by the Member Bodies of the following countries :

Australia	Germany	Romania
Austria	Hungary	South Africa, Rep. of
Belgium	Iran	Spain
Bulgaria	Ireland	Sweden
Chile	Japan	Switzerland
Czechoslovakia	Netherlands	Turkey
Finland	Poland	Yugoslavia
France	Portugal	

The Member Bodies of the following countries expressed disapproval of the document on technical grounds :

Italy
United Kingdom

This International Standard cancels and replaces ISO Recommendation R 1724-1970, of which it constitutes a technical revision.

Road vehicles — Electrical connections between towing vehicles and towed vehicles with 6 or 12 V electrical equipment — Type 12 N (normal)

1 SCOPE

This International Standard establishes specifications which will permit, by means of a socket and a plug, type 12 N, interchangeability of electrical connections between towing vehicles and towed vehicles (see figure 3).

2 FIELD OF APPLICATION

These specifications apply to vehicles fitted with electrical equipment operating at a nominal voltage of 6 or 12 V.

3 GENERAL REQUIREMENTS

3.1 Number of necessary contacts

The essential signalling lights for road safety require six contacts. The functions of the seven contacts provided are as follows :

- 1 Left-hand direction-indicator light.
- 2 No allocation.¹⁾
- 3 Common return.
- 4 Right-hand direction-indicator light.
- 5 Right-hand rear position and end-outline marker light, and rear-registration-plate illuminating device.
- 6 Stop lights.
- 7 Left-hand rear position and end-outline marker light, and rear-registration-plate illuminating device.

NOTE — The rear-registration-plate illuminating device shall be connected in such a manner that no lamp of such a device has a common connection with both contacts 5 and 7.

3.2 Arrangement of the contacts

The arrangement of the contacts is shown in figures 1 (socket) and 2 (plug).

The numbers designating the contacts correspond to those indicated in 3.1.

3.3 Socket

The socket shall be mounted on the rear of the towing vehicle.

The socket is provided with :

- 4 tubes (Nos. 1, 3, 4, 6)
- 3 spring pins (Nos. 2, 5, 7)

Tube and pin design details are given in figure 1.

Pins shall be able to spring back over a minimum length of 8,5 mm. The diameter of the pins shall be such that the corresponding tubes of the plug can be connected with a moderate push, but they shall ensure a good electrical contact.

Contact No. 3 shall be insulated, as are the other contacts. After fitting, contact No. 3 may be connected to the common return of the vehicle.

The rear terminals shall each be capable of receiving two conductors of at least 1,5 mm² cross-section.

The contact designations shall be permanently marked on the inside of the socket cover and on the terminal face (except where the cable is moulded into the socket) in symbols not less than 2 mm high. These symbols, which need not necessarily be numbers, may be different from those indicated in figure 1, provided that the specified pin locations of the different functions are complied with.

The socket shall be provided with a splashproof cover which shall close automatically when the plug is disengaged. The hinged cover on the socket shall be provided with a lip to retain the plug when it is engaged.

All metallic parts of the socket shall be made of corrosion-resistant material or shall be adequately protected against corrosion.

1) This contact shall be kept free pending the establishment of a requirement of a legal or safety nature that would be a common factor.

3.4 Plug

The plug shall be mounted on the trailer.

The plug is provided with :

- 4 spring pins (Nos. 1, 3, 4, 6)
- 3 tubes (Nos. 2, 5, 7)

The rear terminals shall each be capable of receiving one conductor of at least 2,5 mm² cross-section.

The contact designations shall be permanently marked on the terminal face (except where the cable is moulded into the plug) in symbols not less than 2 mm high. These symbols, which need not necessarily be numbers, may be different from those indicated in figure 2, provided that the specified pin locations of the different functions are complied with.

All metallic parts of the plug shall be made of corrosion-resistant material or shall be adequately protected against corrosion.

The manufacturer shall provide means for fixing and sealing the cable.

3.5 Allocation of cable colours

The cable colours of the seven-core connecting cable shall be allocated to the different circuits as follows :

Contact No.	Circuit	Cable colour
1	Left-hand direction-indicator light	yellow
2	No allocation	blue
3	Common return	white
4	Right-hand direction-indicator light	green
5	Right-hand rear position and end-outline marker light, and rear-registration-plate illuminating device	brown
6	Stop lights	red
7	Left-hand rear position and end-outline marker light, and rear-registration-plate illuminating device	black

3.6 Distinguishing marking

The 12 N connector shall be distinguished from the 12 S connector (see ISO 3732) by means of a different colouring at least of the insulating parts.

A dark and permanent colour, preferably black, shall be used for the 12 N connector.

Dimensions in millimetres

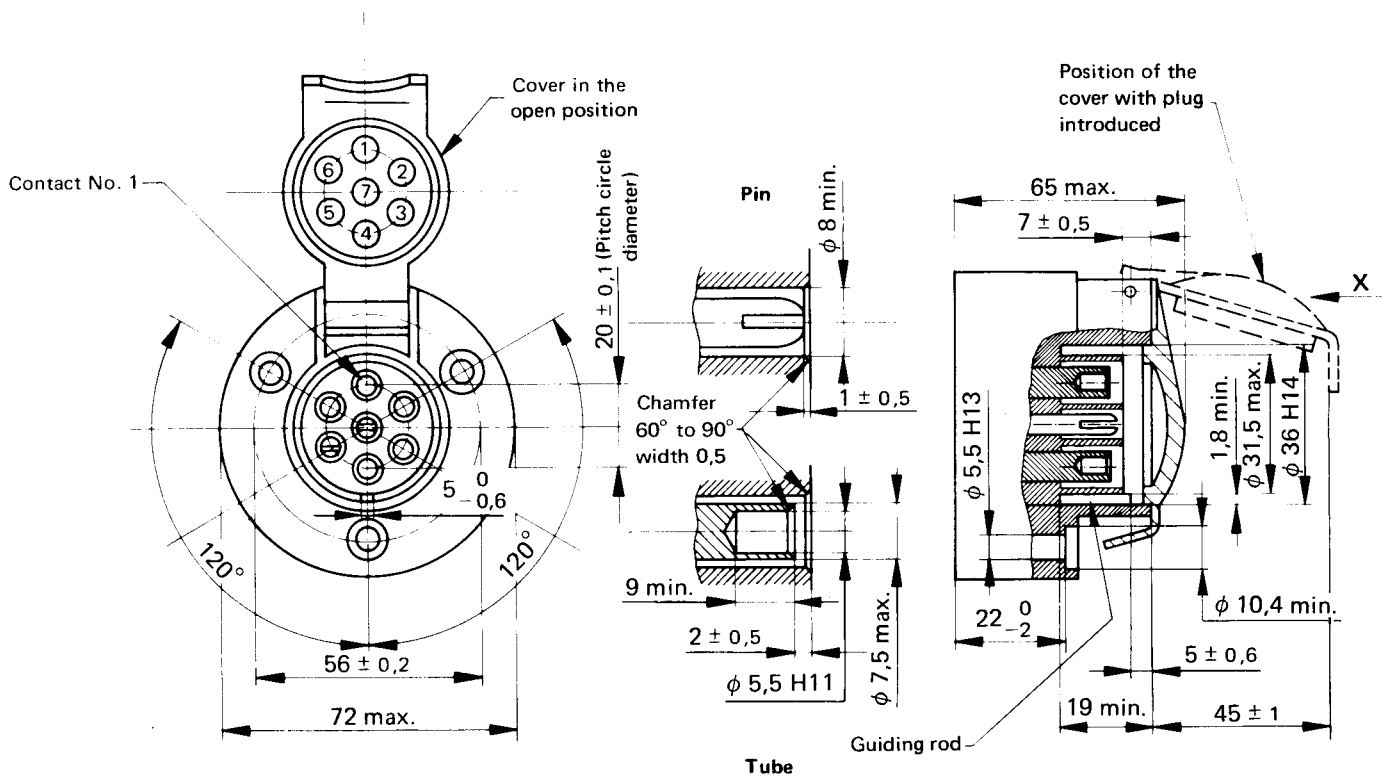

Cover view along X

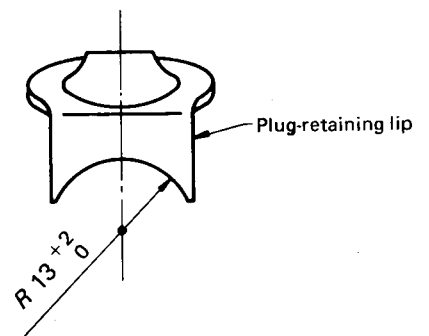

FIGURE 1 – Socket

Dimensions in millimetres

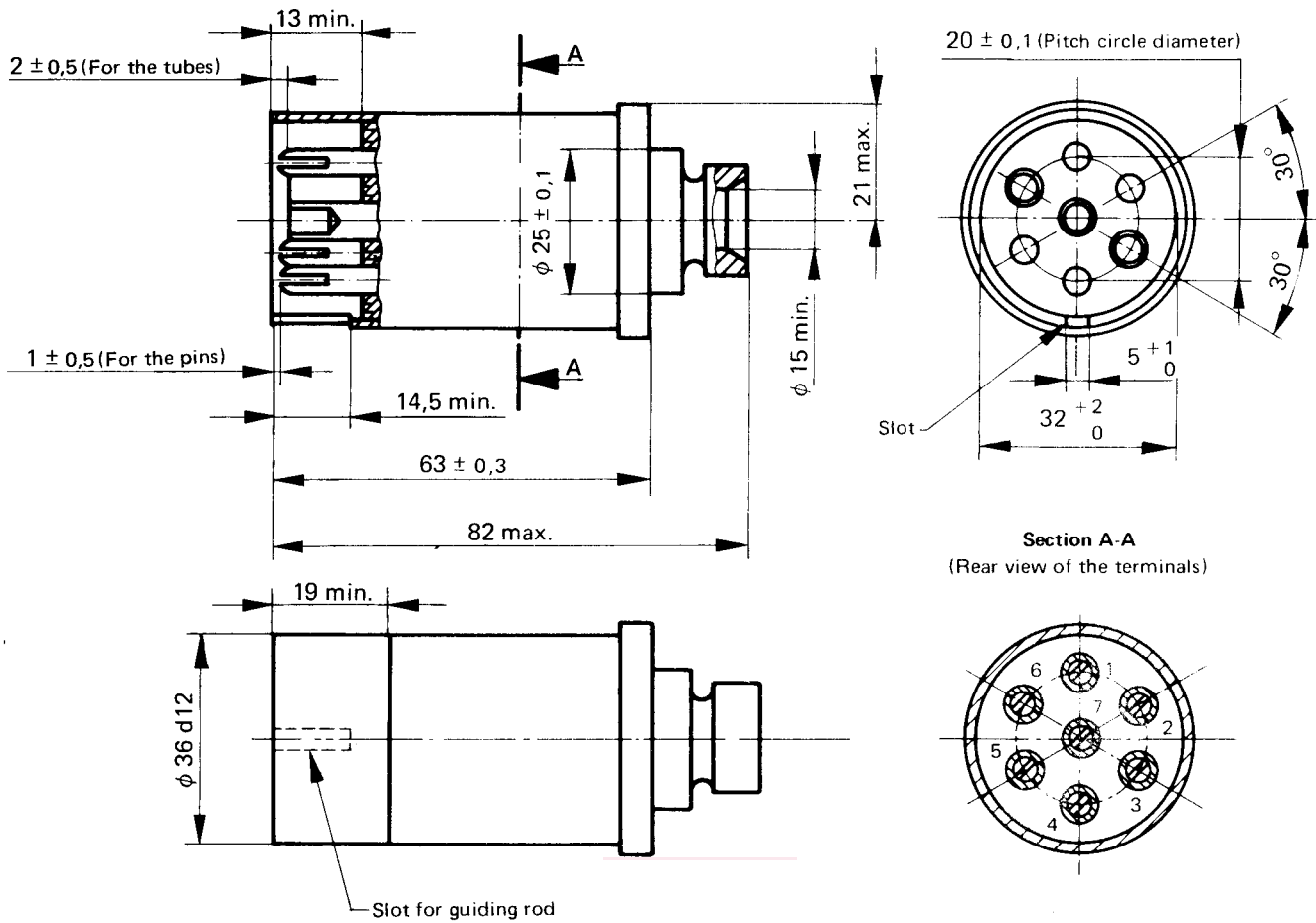
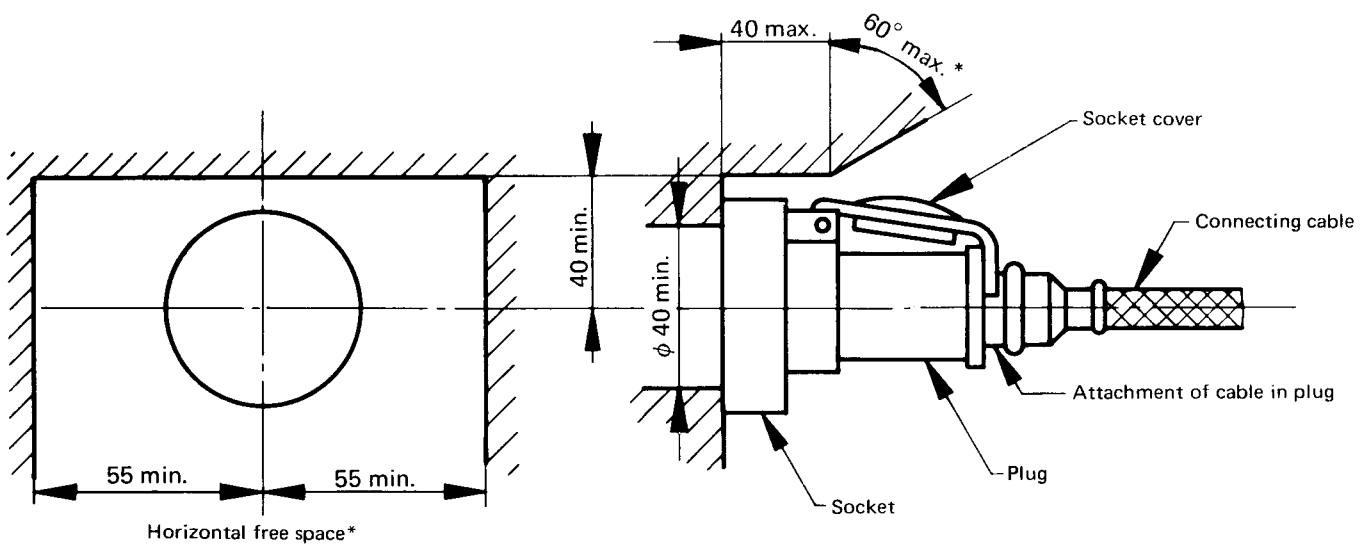

FIGURE 2 — Plug



* The angle of 60° max. shall extend across the full horizontal free space.

FIGURE 3 — Socket and plug assembly (free space)

iTeh STANDARD PREVIEW
(standards.iteh.ai)

ISO 1724:1975

<https://standards.iteh.ai/catalog/standards/sist/55b9295f-9b33-41c9-bc38-22cda8613023/iso-1724-1975>