



Standard Specification for Dimensions and Tolerances for Plastic Bottles¹

This standard is issued under the fixed designation D 2911; the number immediately following the designation indicates the year of original adoption or, in the case of revision, the year of last revision. A number in parentheses indicates the year of last reapproval. A superscript epsilon (ϵ) indicates an editorial change since the last revision or reapproval.

1. Scope

1.1 This specification covers the thread configuration and dimensions for finishes for plastic bottles with screw-type closures, having a maximum capacity of 18.9 L (5 gal) and a maximum bottle dimension of 305 mm (12 in.). Included are tolerances for bottle capacity and body dimensions.

1.2 The values stated in SI units are to be regarded as the standard.

1.3 The following precautionary caveat pertains only to the test methods portion, Section 8 of this specification. *This standard does not purport to address all of the safety concerns, if any, associated with its use. It is the responsibility of the user of this standard to establish appropriate safety and health practices and determine the applicability of regulatory limitations prior to use.*

NOTE 1—There is no similar or equivalent ISO standard.

2. Referenced Documents

2.1 ASTM Standards:

D 618 Practice for Conditioning Plastics and Electrical Insulating Materials for Testing²

D 1898 Practice for Sampling of Plastics²

3. Terminology

3.1 Definitions:

3.1.1 *bottle finish*—the configuration of the neck or opening of the bottle which serves to engage specific parts of the closure in order to securely attach it to the bottle.

3.1.2 *bottle height*—the maximum dimension of a bottle in a plane perpendicular to the bottle base when the bottle is setting in its normal upright position.

3.1.3 *bottle thickness*—the smaller dimension in a plane parallel to the bottle base.

3.1.4 *bottle width*—the larger dimension in a plane parallel to the bottle base.

4. Dimensions and Recommended Variations

4.1 *Recommended Variations in Overflow Capacity*—In overflow capacity recommended variations of plastic bottles up

to 18.9 L (5 gal) in size shall be in accordance with Table 1.

4.2 *Recommended Variations in Body Dimensions*—The recommended variations in the body dimensions of plastic bottles covered by this specification shall be in accordance with Table 2.

4.3 *Finish Dimensions and Design*—The bottle finish dimensions and design for the nine finishes covered by this specification shall be in accordance with Figs. 1-8 and Tables 3-10.

5. Sampling

5.1 A batch or lot shall be considered as a unit of manufacture.

5.2 Unless otherwise agreed upon between manufacturer and purchaser, the material shall be sampled in accordance with the procedure described in Section 9 of Practice D 1898. Adequate statistical sampling prior to packaging shall be considered an acceptable alternative.

6. Conditioning

6.1 *Conditioning*—Condition the test specimens at $23 \pm 2^\circ\text{C}$ ($73.4 \pm 3.6^\circ\text{F}$) and $50 \pm 5\%$ relative humidity for not less than 40 h prior to test in accordance with Procedure A of Practice D 618 for those tests where conditioning is required. In cases of disagreement, the tolerances shall be $\pm 1^\circ\text{C}$ ($\pm 1.8^\circ\text{F}$) and $\pm 2\%$ relative humidity.

6.2 *Test Conditions*—Conduct tests in the standard laboratory atmosphere of $23 \pm 2^\circ\text{C}$ ($73.4 \pm 3.6^\circ\text{F}$) and $50 \pm 5\%$ relative humidity, unless otherwise specified in the test methods or in this specification. In cases of disagreement, the tolerances shall be $\pm 1^\circ\text{C}$ ($\pm 1.8^\circ\text{F}$) and $\pm 2\%$ relative humidity.

7. Apparatus

7.1 For Determining Bottle Capacity:

7.1.1 *Balance*, having an accuracy of $\pm 0.1\%$ or better at rated capacity (full scale).

7.1.2 *Pipet, Graduated Cylinder, and Beaker*, as required.

7.1.3 Conditioned water at $23 \pm 2.0^\circ\text{C}$ ($73.4 \pm 3.6^\circ\text{F}$) containing a wetting agent sufficient to flatten the meniscus and eliminate air bubbles.

NOTE 2—Any liquid detergent may be used as the wetting agent.

7.1.4 *Stop Watch*.

7.2 *For Determining Finish and Body Dimensions:*

¹ This specification is under the jurisdiction of Committee D-20 on Plastics and is the direct responsibility of Subcommittee D 20.20 on Plastic Products.

Current edition approved June 15, 1994. Published August 1994. Originally published as D 2911 – 70. Last previous edition D 2911 – 93a.

Explanatory notes to Table 3 were added in this edition.

² *Annual Book of ASTM Standards*, Vol 08.01.

TABLE 1 Bottle Overflow Capacity Tolerances for Plastic Bottles

Fluid Ounces				Millilitres			
Bottle Overflow Capacity		Tolerance (\pm)		Bottle Overflow Capacity		Tolerance (\pm)	
0.75	less than	0.75	0.05	less than	22	1.5	
	and less than	1.2	0.07	22	and less than	35	2.0
1.2	and less than	1.6	0.08	35	and less than	47	2.5
1.6	and less than	2.1	0.10	47	and less than	62	3.0
2.1	and less than	2.8	0.12	62	and less than	83	3.5
2.8	and less than	3.9	0.14	83	and less than	115	4
3.9	and less than	5.4	0.17	115	and less than	159	5
5.4	and less than	7.4	0.20	159	and less than	218	6
7.4	and less than	9.8	0.24	218	and less than	289	7
9.8	and less than	13	0.30	289	and less than	384	9
13	and less than	18	0.37	384	and less than	531	11
18	and less than	26	0.44	531	and less than	767	13
26	and less than	37	0.51	767	and less than	1092	15
37	and less than	51	0.68	1092	and less than	1505	20
51	and less than	72	0.81	1505	and less than	2125	24
72	and less than	98	1.01	2125	and less than	2892	30
98	and less than	119	1.30	2892	and less than	3512	38
119	and less than	139	1.50	3512	and less than	4103	44
139	and less than	160	1.80	4103	and less than	4723	53
160	and less than	180	2.00	4723	and less than	5313	59
180	and less than	210	2.20	5313	and less than	6199	65
210	to 5 gallons		1 % of capacity	6199	to 18.89 litres		1 % of capacity

TABLE 2 Body Dimensional Tolerance

Range of Specific Dimensions			Height Dimensions		Width and Depth Dimensions	
in.		mm	in.	mm	in.	mm
0 up to but not including	1	0 to 25.40	0.030	0.76	0.030	0.76
1 up to but not including	2	25.40 to 50.80	0.030	0.76	0.050	1.27
2 up to but not including	4	50.80 to 101.60	0.050	1.27	0.060	1.52
4 up to but not including	6	101.60 to 152.40	0.050	1.27	0.080	2.03
6 up to but not including	8	152.40 to 203.20	0.060	1.52	0.090	2.29
8 up to but not including	10	203.20 to 254.00	0.060	1.52	0.110	2.79
10 up to but not including	12	254.00 to 304.80	0.080	2.03	0.120	3.05
12 up to but not including	15	304.80 to 381.00	0.090	2.29	0.150	3.81
15 up to but not including	18	381.00 to 457.20	0.110	2.79	0.150	3.81

ASTM D2911-94

7.2.1 *Micrometers, Vernier Height Gages, or Vernier Calipers* with an accuracy of ± 0.025 mm (± 0.001 in.).

7.2.2 *Internal Micrometers or Telescoping Gages* with an accuracy of ± 0.025 mm (± 0.001 in.).

7.2.3 *Commercial Scale*, good quality calibrated in 1-mm or $\frac{1}{32}$ -in. increments.

8. Test Methods

8.1 Bottle Capacity:

8.1.1 Weigh the empty bottle and record the weight in grams.

8.1.2 Fill the bottle to overflow capacity with conditioned water containing the wetting agent, adjusting the meniscus by use of a pipet, if necessary, until the meniscus is tangent to the top of the finish surface. No more than 2 min shall be allowed for filling the bottle and no additional water shall be added after the bottle is filled to overflow and free of air bubbles.

8.1.3 If the time exceeds 2 min, discard the sample and start over.

NOTE 3—The capacity of the container is somewhat time-dependent in that the force of the water in the container will cause the container sides to bulge with time and additional water will be needed to adjust to overflow capacity.

8.1.4 Weigh the filled bottle and record the weight in grams.

8.1.5 Calculate the bottle volume as follows:

$$B_v \text{ (mL)} = (B_f - B_e)/0.997$$

where:

B_v = volume of bottle, mL,

B_f = weight of filled bottle, g,

B_e = weight of empty bottle, g, and

0.997 = weight of water (g/mL) at $23 \pm 2.0^\circ\text{C}$ ($73.4 \pm 3.6^\circ\text{F}$).

$$B_v \text{ (fluid oz)} = (B_f - B_e)/29.50$$

where: 29.50 = weight of water (g/fluid oz) at $23 \pm 2.0^\circ\text{C}$ ($73.4 \pm 3.6^\circ\text{F}$).

8.1.6 Determine the volume in millilitres (fluid ounces) for each test specimen.

8.1.7 Report the arithmetic average volume of the specimens tested as the bottle capacity of the batch or lot from which the samples were chosen.

8.2 Body Dimensions:

8.2.1 Using a suitable micrometer, a vernier height gage, or a scale, measure the height of the bottle.

NOTE 4—If the top of the finish is parallel to the base of the container and the height must be measured from the top of the finish, and a commercial scale is used, one method is to place the bottle on a flat surface and a straightedge across the top of the bottle finish. Then measure

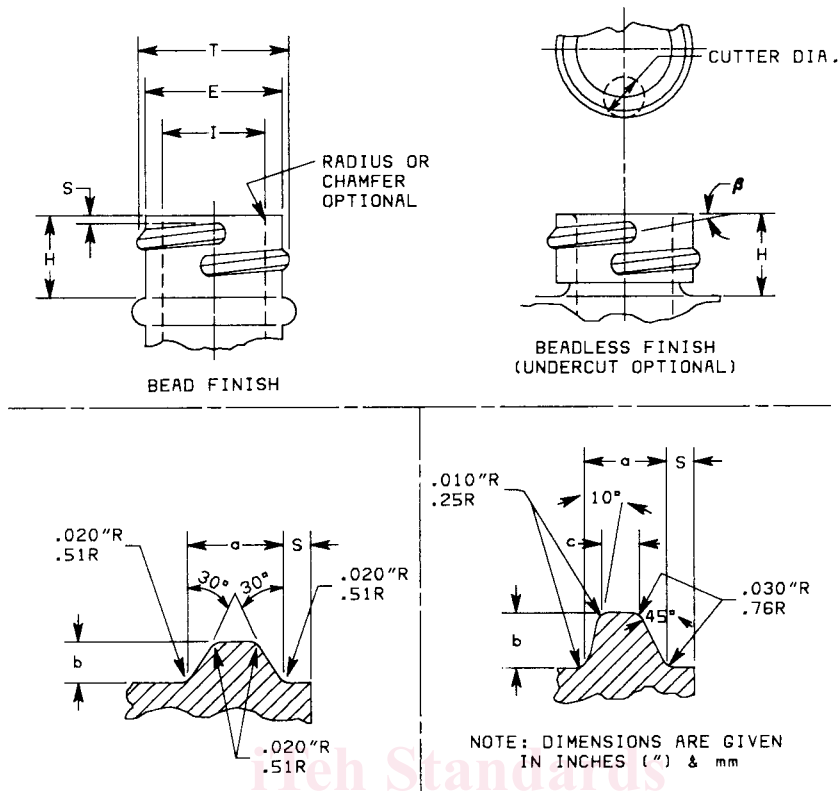

"L" Style All-Purpose Thread (Plastic or Metal Closures)				"M" Style Modified Buttress Thread (Plastic Closures)			
Threads/in.	a	b	c	Threads/in.	a	b	c
5	in. 0.120	0.060	0.051	5	in. 0.120	0.060	0.049
	mm 3.05	1.52	1.30		mm 3.05	1.52	1.24
6	in. 0.094	0.047	0.040	6	in. 0.094	0.047	0.039
	mm 2.39	1.19	1.02		mm 2.39	1.19	0.99
8	in. 0.084	0.042	0.036	8	in. 0.084	0.042	0.035
	mm 2.13	1.07	0.91		mm 2.13	1.07	0.89

Example Thread Nomenclature
 "L" Style: L28SP400
 "M" Style: M28SP400

NOTE 1—*T* and *E* dimensions are the average of two measurements across the major and minor axis. The limits of ovality will be determined by the container supplier and container customer, as necessary.

NOTE 2—Dimension *H* is measured from the top of the finish to the point where diameter *T*, extended parallel to the centerline, intersects the bead or shoulder.

NOTE 3—Contour of bead, undercut or shoulder is optional.

NOTE 4—Unless otherwise specified, *I* min applies to the full length of the opening.

NOTE 5—Concentricity of *I* min with respect to diameters *T* and *E* is not included. *I* min is specified for filler tube only.

NOTE 6—A minimum of 1 full turn of thread shall be maintained.

NOTE 7—Corresponding dimensions and finish details are shown in Table 3.

NOTE 8—Consideration must be given to the sealing surface width for the sealing system being used.

NOTE 9—Many child resistant closures, etc.

FIG. 1 SP 400 Finish Thread Cross Sections

the perpendicular distance between the straightedge and the surface upon which the bottle is setting. Four measurements should be made, each 90° apart and the maximum used as the bottle height.

8.2.2 Using a suitable micrometer or vernier caliper, measure the width and thickness of the bottle.

8.2.2.1 In the case of a rectangular container, use the midpoints of the sides as the measuring points.

8.2.2.2 For a cylindrical container, make one measurement on the parting line and another measurement 90° from the parting line. Use the average of these two measurements as the container width.

NOTE 5—If, because of the shape of the container, there is some question about where the measurements should be taken, the agreement

NOTE: DIMENSIONS ARE GIVEN IN INCHES (") & mm

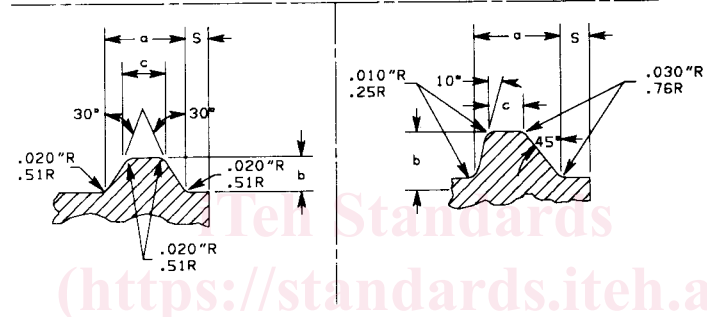
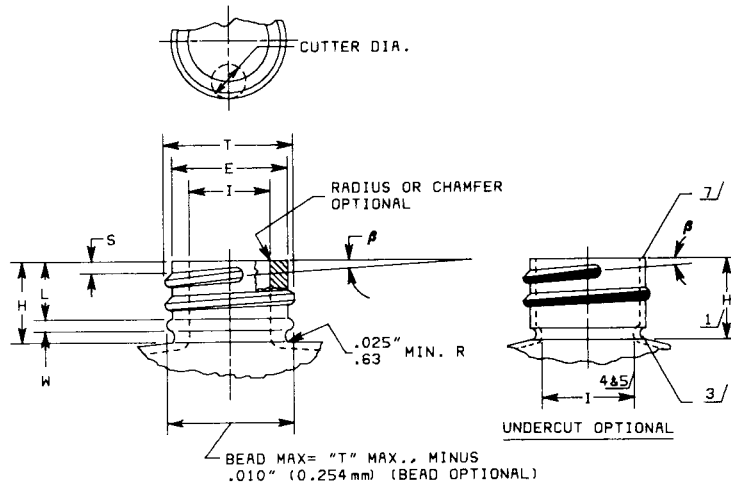

"L" Style All-Purpose Thread (Plastic or Metal Closures)					"M" Style Modified Buttress Thread (Plastic Closures)			
Threads/in.		a	b	c	Threads/in.	a	b	c
6	in.	0.094	0.047	0.040	6	in.	0.094	0.039
	mm	2.39	1.19	1.02	6	mm	2.39	0.99
8	in.	0.084	0.042	0.036	8	in.	0.084	0.035
	mm	2.13	1.07	0.91	8	mm	2.13	0.89

Example Thread Nomenclature:
 "L" Style: L22SP410
 "M" Style: M22SP410

- NOTE 1—Construction of neck from B to D must be held within the shaded area shown.
- NOTE 2—A minimum of 1½ turns of thread shall be maintained.
- NOTE 3—Unless otherwise specified, I min applies to the full length of the opening.
- NOTE 4—Concentricity of I min with respect to diameters T and E is not included. I min is specified for filler tube only.
- NOTE 5—T and E dimensions are the average of two measurements across the major and minor axis. The limits of ovality will be determined by the container supplier and container customer, as necessary.
- NOTE 6—Consideration must be given to the sealing surface width for the sealing system being used.
- NOTE 7—When valve style closures are used with this finish, special consideration must be given to a specific controlled inside diameter. In addition, dimensions indicated with asterisk (*) may be varied to ensure adequate material for finishing the inside diameter.
- NOTE 8—Corresponding dimensions and details shown in Table 4.

FIG. 2 SP 410 Finish Thread Cross Sections

should be reached between the purchaser and the seller.

8.3 *Finish Dimensions*—Using suitable micrometers, vernier calipers, or telescoping gages, measure the finish dimensions of the bottle.

9. Retest and Rejection

9.1 If the results of any test do not conform to the require-

ments of this specification, retesting to determine conformity may be performed as agreed upon between the purchaser and the seller.

NOTE: DIMENSIONS ARE GIVEN IN INCHES (*) & mm

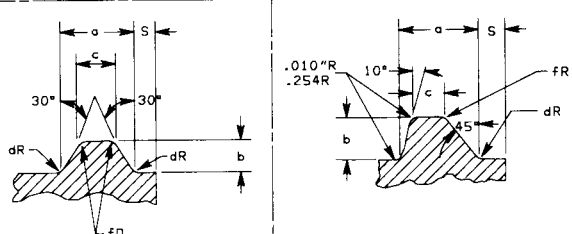
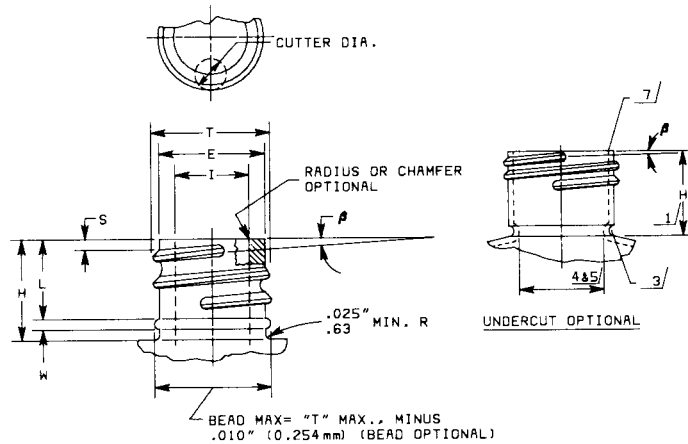

iTeh Standards

"L" Style All-Purpose Thread (Plastic or Metal Closures)						"M" Style Modified Buttress Thread (Plastic Closures)					
Threads/in.	a	b	c	d	f	Threads/in.	a	b	c	d	f
6	in. 0.094	0.047	0.040	0.020	0.020	6	in. 0.094	0.047	0.039	0.030	0.030
	mm 2.39	1.19	1.02	0.51	0.51		mm 2.39	1.19	0.99	0.76	0.76
8	in. 0.084	0.042	0.036	0.020	0.020	8	in. 0.084	0.042	0.035	0.030	0.030
	mm 2.13	1.07	0.91	0.51	0.51		mm 2.13	1.07	0.89	0.76	0.76
12	in. 0.045	0.030	0.011	0.015	0.005	12	in. 0.051	0.030	0.016	0.020	0.008
	mm 1.14	0.76	0.28	0.38	0.13		mm 1.29	0.76	0.41	0.51	0.22

Example Thread Nomenclature:
 "L" Style: L22SP415
 "M" Style: M22SP415

- NOTE 1—Construction of neck from B to D must be held within the shaded area shown.
- NOTE 2—A minimum of 2 turns of thread shall be maintained.
- NOTE 3—Unless otherwise specified, I min applies to the full length of the opening.
- NOTE 4—Concentricity of I min with respect to diameters T and E is not included. I min is specified for filler tube only.
- NOTE 5—T and E dimensions are the average of two measurements across the major and minor axis. The limits of ovality will be determined by the container supplier and container customer, as necessary.
- NOTE 6—Consideration must be given to the sealing surface width for the sealing system being used.
- NOTE 7—When valve style closures are used with this finish, special consideration must be given to a specific controlled inside diameter. In addition, dimensions indicated with asterisk (*) may be varied to ensure adequate material for finishing the inside diameter.
- NOTE 8—Corresponding dimensions and finish details are shown in Table 5.

FIG. 3 SP 415 Finish Thread Cross Sections

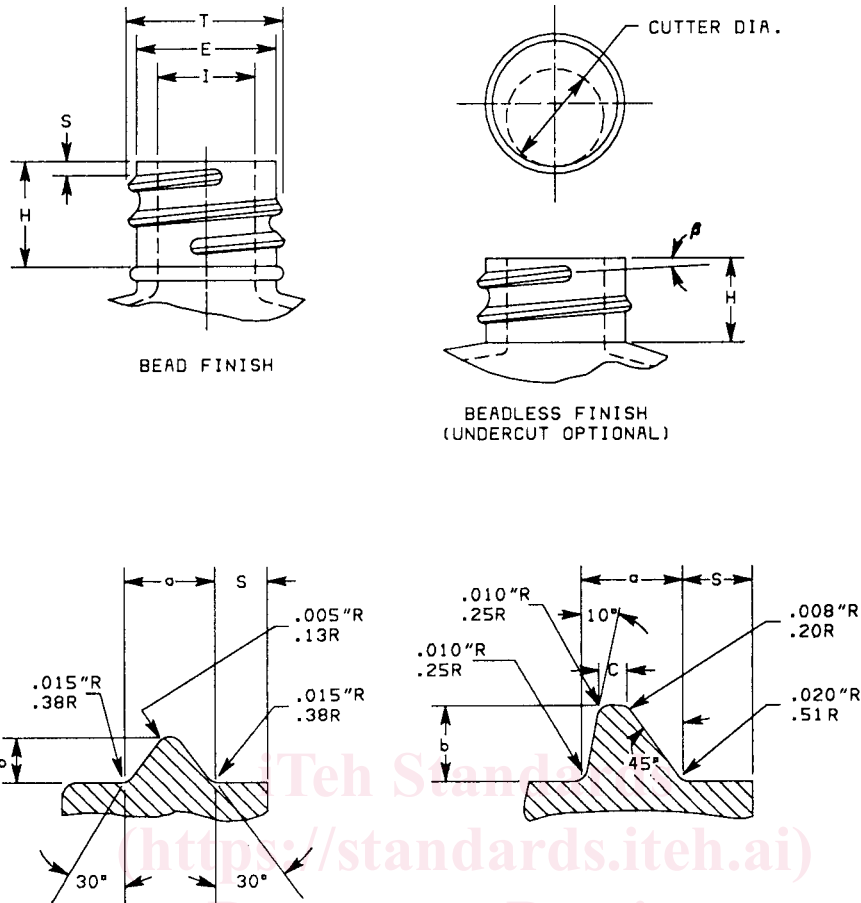

NOTE: DIMENSIONS ARE GIVEN IN INCHES (") & mm

NOTE 1—Contour of bead, undercut, or shoulder is optional.

"L" Style All-Purpose Thread (Plastic or Metal Closures)				"M" Style Modified Buttress Thread (Plastic Closures)			
Threads/in.		a	b	Threads/in.	a	b	c
12	in.	0.045	0.030	12	in.	0.051	0.030
	mm	1.14	0.76		mm	1.29	0.76
12	in.	0.045	0.030	12	in.	0.051	0.030
	mm	1.14	0.76		mm	1.29	0.76

NOTE 2—Example Thread Nomenclature
 "L" Style: L15SP425 or "M" Style M15SP425

NOTE 3—Corresponding dimensions and finish details are shown in Table 6.

FIG. 4 SP 425 Finish Thread Cross Sections