



Standard Test Method for Permeability of Thermoplastic Containers to Packaged Reagents or Proprietary Products¹

This standard is issued under the fixed designation D 2684; the number immediately following the designation indicates the year of original adoption or, in the case of revision, the year of last revision. A number in parentheses indicates the year of last reapproval. A superscript epsilon (ϵ) indicates an editorial change since the last revision or reapproval.

1. Scope

1.1 This test method covers procedures for determining the permeability of thermoplastic containers to packaged reagents or proprietary products under specified conditions of exposure. The exposures used are intended to simulate the normal and elevated temperature-storage conditions that might be encountered in end-use application.

1.2 This test method is applicable only to those types of containers designed to allow positive, leakproof closure.

1.3 Two procedures are provided:

1.3.1 *Procedure A* is specific to testing only with a standard design container. This procedure provides for determinations of rate of weight loss (or gain) and for calculation of a permeability factor.

1.3.2 *Procedure B* applies to tests of all other container designs. Permeability data by this procedure are expressed only in terms of rate of weight loss (or gain) for the particular container tested.

1.4 The values stated in SI units are to be regarded as the standard.

NOTE 1—There is no similar or equivalent ISO Standard.

1.5 *This standard does not purport to address all of the safety concerns, if any, associated with its use. It is the responsibility of the user of this standard to establish appropriate safety and health practices and determine the applicability of regulatory limitations prior to use.*

2. Referenced Documents

2.1 ASTM Standards:

D 618 Practice for Conditioning Plastics and Electrical Insulating Materials for Testing²

D 1248 Specification for Polyethylene Plastics Molding and Extrusion Materials²

D 1505 Test Method for Density of Plastics by the Density-Gradient Technique²

E 145 Specification for Gravity-Convection and Forced-Ventilation Ovens³

3. Terminology

3.1 Definitions:

3.1.1 *permeability factor, P_t* —the permeability of a given plastic to a given product at temperature t , in degrees Celsius, expressed in units of g-cm/day-m², as determined by Procedure A. The permeability factor under 23°C test conditions, for example, is signified by the notation P_{23} .

3.1.2 Determination of P_t is based on an averaged wall thickness over the entire area of the container and an assumption that permeation rate is inversely proportional to the thickness. Precaution in the extent of allowable variations of these factors is recommended, and use of P_t should take into consideration that wall thickness of the containers varies, that the estimate of average thickness from density, area, and weight is not exact, and that permeability of the product through the plastic material may not be directly proportional to the thickness.

4. Summary of Test Method

4.1 Test bottles are filled with the test product and, after sealing, are exposed at 23°C (73.4°F) and 50°C (122°F) conditions for 28 days or longer. Measurements of weight are made at intervals to determine the average rate of weight change.

5. Significance and Use

5.1 With the proper precautions and background experience, results can be useful for estimation of the loss of a packaged product through the walls of a container during shelf storage. The test is also useful for isolating the effects of a container design and materials, and is applicable for development and research and for specification purposes.

5.2 In the absence of adequate supporting data, extrapolations or correlations of results to conditions beyond those of the test are not recommended because of possible product alteration, solvency, or chemical effects on the plastic, etc.

5.3 Before proceeding with this test method, reference should be made to the specification of the material being tested. Any test specimen preparation, conditioning, dimensions, or testing parameters, or combination thereof, covered in the materials specification shall take precedence over those mentioned in this test method. If there are no material specifications, then the default conditions apply.

¹ This test method is under the jurisdiction of ASTM Committee D-20 on Plastics and is the direct responsibility of Subcommittee D20.20 on Plastic Products.

Current edition approved Nov. 10, 1995. Published January 1996. Originally published as D 2684 – 68 T. Last previous edition D 2684 – 89.

² *Annual Book of ASTM Standards*, Vol 08.01.

³ *Annual Book of ASTM Standards*, Vol 14.02.

6. Apparatus

6.1 *Enclosure* or room with provision for maintaining the standard laboratory atmosphere of $23 \pm 2^\circ\text{C}$ ($73.4 \pm 3.6^\circ\text{F}$) and $50 \pm 5\%$ relative humidity, as defined by Practice D 618.

6.2 *Circulating-Air Oven*, consistent with ovens in accordance with Specification E 145, capable of maintaining a temperature of $50 \pm 1^\circ\text{C}$ ($122 \pm 1.8^\circ\text{F}$) and an airflow rate of 8.5 to 17.0 m³/min (300 to 600 ft³/min). The limitation of 25 ft³ on oven size can be overlooked, provided all other requirements are met.

NOTE 2—Only explosion-proof equipment with provision for adequate exhaust of vapors should be used for tests with potentially hazardous or toxic products.

NOTE 3—Relative humidity variation can significantly affect permeability loss in many products, especially water-based products in various thermoplastics. Therefore, the user may find it useful to equip the oven with a means to measure relative humidity and to record the same during the period of test.

6.3 *Balance*, accurate to 0.01 % of the weight of test container and contents.

6.4 *Container Seals*, suitable heat-sealing laminate⁴ and polyethylene or other suitably lined screw-type closures for sealing the containers.

6.5 *Heat Sealer*.⁵

6.6 *Torque Wrench*.⁶

7. Reagents and Materials

7.1 The reagent or proprietary product as specified for testing.

8. Test Specimens

8.1 The test specimen for Procedure A shall be the 4-oz cylindrical bottle design as specified in Fig. 1, having a nominal external surface area of 154 cm² (23.8 in.²).

8.2 The test specimen for Procedure B may be any thermoplastic container, as specified or selected for test evaluation, provided it is designed to allow positive closure.

8.3 For each procedure, a minimum of three specimens shall be tested at each temperature. Three additional specimens are required for Procedure A for determination of the plastic density.

NOTE 4—Trim and finish the containers, if needed, to ensure a smooth contacting surface for positive seal.

9. Conditioning

9.1 *Conditioning*—Condition the test specimens at $23 \pm 2^\circ\text{C}$ ($73.4 \pm 3.6^\circ\text{F}$) and $50 \pm 5\%$ relative humidity for not less than 40 h prior to test in accordance with Procedure A of Practice D 618, for those tests where conditioning is required. In cases of disagreement, the tolerances shall be $\pm 1^\circ\text{C}$ ($\pm 1.8^\circ\text{F}$) and $\pm 2\%$ relative humidity.

⁴ One such laminate suitable for polyethylene containers, MIL-B-131C Class 2, a polyethylene-aluminum foil-paper laminate available from the Robertson Co., Jamaica, NY. Heat sensitive seals are also available from 3M Packaging Systems Division, 3M Center Building 220-8W-01, St. Paul, MN, 55144.

⁵ Super Sealer made by Ciamco Corp., 12900 Plaza Dr., Cleveland, OH 44130 is suitable.

⁶ Model 25 Owens-Illinois Torque Tester, Model MRA available from Secure Pak, Inc., P.O. Box 14499, Toledo, OH 43614 is suitable.

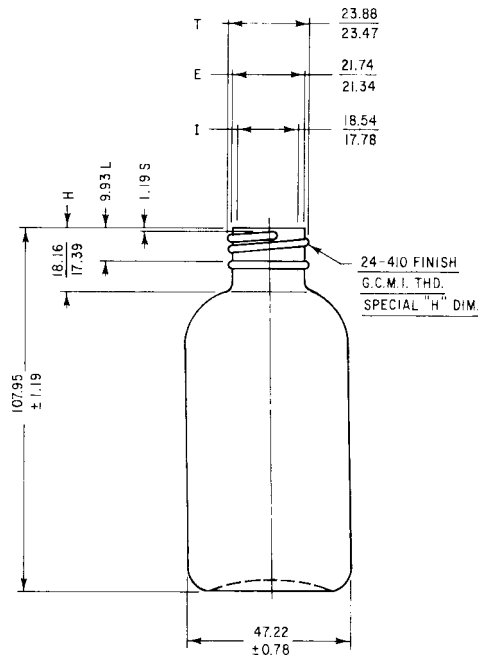

NOTE 1—Dimensions are in millimetres.

FIG. 1 Standard Container for Permeability Test

9.2 *Test Conditions*—Conduct tests in the standard laboratory atmosphere of $23 \pm 2^\circ\text{C}$ ($73.4 \pm 3.6^\circ\text{F}$) and $50 \pm 5\%$ relative humidity, unless otherwise specified in the test methods. In cases of disagreements, the tolerances shall be $\pm 1^\circ\text{C}$ ($\pm 1.8^\circ\text{F}$) and $\pm 2\%$ relative humidity.

10. Procedure A (Standard Container)

10.1 With specimens taken from the sidewalls of three of the containers, determine the average plastic density by Test Method D 1505, or by an alternative method of equivalent accuracy.

10.2 For each test temperature, select a minimum of three containers. Weigh each when empty, without the closure. Also weigh the empty containers with their corresponding closures and appropriately sized laminate pieces.

10.3 Fill the containers to nominal capacity with the test product.

10.4 Make a thorough check for any drippage or spill of product on the outside surface of the containers. If any is noted, replace the container with a new specimen.

10.5 Heat seal the containers with the laminate (plastic to plastic), check for leaks, and then cap the containers with screw-type closures, using sufficient torque to provide positive seal. Avoid distorting the container when capping.

NOTE 5—One method of testing for a poor seal is to immerse an upright test container in a beaker filled to the base of the cap with a liquid that will not attack the plastic. When a vacuum of 15 in. Hg is applied to the entire system, a poorly sealed bottle will give off bubbles from the sealed area.

NOTE 6—Any deformation of the container during sealing may result in a volume change which will affect the final test pressure. An application torque of 1.7 N·m (15 lbf·in.) has been found sufficient for the standard container in Fig. 1.

10.6 Weigh the sealed containers.

10.7 Unless otherwise specified, expose one set of containers in the Standard Laboratory Atmosphere, $23 \pm 2^\circ\text{C}$ ($73.4 \pm$