



Standard Test Method for In-Plane Shear Strength of Pultruded Glass-Reinforced Plastic Rod¹

This standard is issued under the fixed designation D 3914; the number immediately following the designation indicates the year of original adoption or, in the case of revision, the year of last revision. A number in parentheses indicates the year of last reapproval. A superscript epsilon (ϵ) indicates an editorial change since the last revision or reapproval.

1. Scope

1.1 This test method covers the determination of the in-plane shear strength of pultruded, glass-fiber reinforced, thermosetting plastic rod of diameters ranging from 19 to 32 mm ($3/4$ to $1\ 1/4$ in.).

1.2 The values stated in SI units are to be regarded as the standard.

1.3 *This standard does not purport to address all of the safety concerns, if any, associated with its use. It is the responsibility of the user of this standard to establish appropriate safety and health practices and determine the applicability of regulatory limitations prior to use.* Specific precautionary statements are given in Note 2 and Note 3.

NOTE 1—There is no similar or equivalent ISO standard.

2. Referenced Documents

2.1 ASTM Standards:

D 618 Practice for Conditioning Plastics for Testing²

D 695 Test Method for Compressive Properties of Rigid Plastics²

E 4 Practices for Force Verification of Testing Machines³

3. Terminology

3.1 Definition:

3.1.1 *in-plane shear strength*—the shear strength at maximum load in which the plane of fracture is centrally located along the longitudinal axis of the specimen between two diametrically opposed notches machined halfway through its diameter.

4. Summary of Test Method

4.1 In-plane shear strength, as determined by this test method, is measured by applying a compressive load to notched cylindrical specimens of the type shown in Fig. 1. Loading of the specimen is accomplished with a subpress, or compression tool, such as those shown in Fig. 1 and Fig. 2 of Test Method D 695. Failure of the specimen occurs in *shear*

¹ This test method is under the jurisdiction of ASTM Committee D-20 on Plastics and is the direct responsibility of Subcommittee D20.18 on Reinforced Thermosetting Plastics.

Current edition approved Nov. 10, 1996. Published May 1997. Originally published as D 3914 – 80. Last previous edition D 3914 – 84 (1990).

² *Annual Book of ASTM Standards*, Vol 08.01.

³ *Annual Book of ASTM Standards*, Vols 03.01 and 04.02.

between two centrally located notches, diametrically opposed and machined halfway through its diameter at a fixed distance apart. The notches are accurately machined in the specimen with maximum reproducibility by means of a special notching jig (Fig. 2a and Fig. 2b) designed specifically for this purpose.

5. Significance and Use

5.1 Shear tests of various kinds are widely used in the reinforced plastics industry to assess the strength of the reinforcement-to-resin bond in polyester-, vinyl ester-, and epoxy-resin composites. In addition to their importance for the generation of data for research and development, quality control, and specification purposes, such tests are of fundamental value to the fibrous reinforcement industry, since they can be used to determine the potential of new sizing systems for the surface treatment of glass fibers.

5.2 The in-plane shear strength of pultruded cylindrical composites is an important property from an engineering standpoint, since pultruded rod, as such, is used in many structural applications.

6. Apparatus

6.1 *Testing Machine*—Any suitable testing machine capable of control of constant-rate-of-crosshead movement and comprising essentially the following:

6.1.1 *Drive Mechanism*—A drive mechanism for imparting to the movable member a uniform, controlled velocity with respect to the stationary member, as required in 10.3.

6.1.2 *Load Indicator*—A load-indicating mechanism capable of showing the total compressive load carried by the test specimen. The mechanism shall be essentially free of inertial lag at the specified rate of testing and shall indicate the load with an accuracy of $\pm 1\%$ of the maximum indicated value of the test (load). The accuracy of the testing machine shall be verified at least once a year in accordance with Practices E 4.

6.1.3 *Notching Jig*—A notching jig of the type shown in Fig. 2a and Fig. 2b, or the equivalent, for notching the test specimens.

6.1.4 *Compression Tool*—A compression tool for applying the load to the test specimen, such as those shown in Fig. 1 and Fig. 2 of Test Method D 695.

6.1.5 *Micrometers*—Suitable micrometers, reading to 0.025 mm or 0.001 in., for measuring the diameter of the specimen, as well as the depth of, and distance between, the notches.

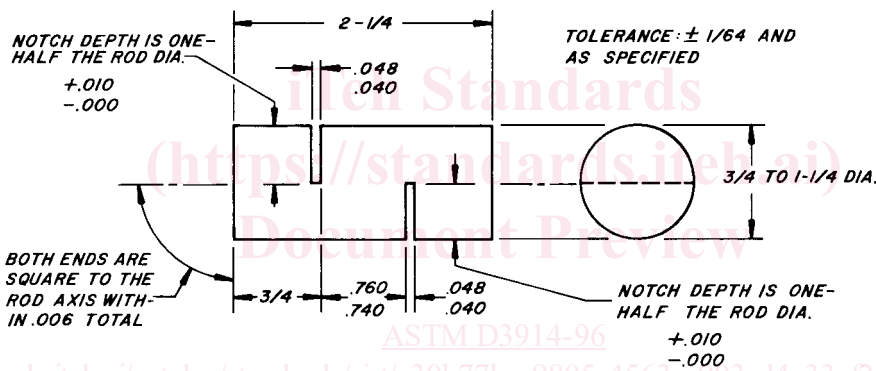
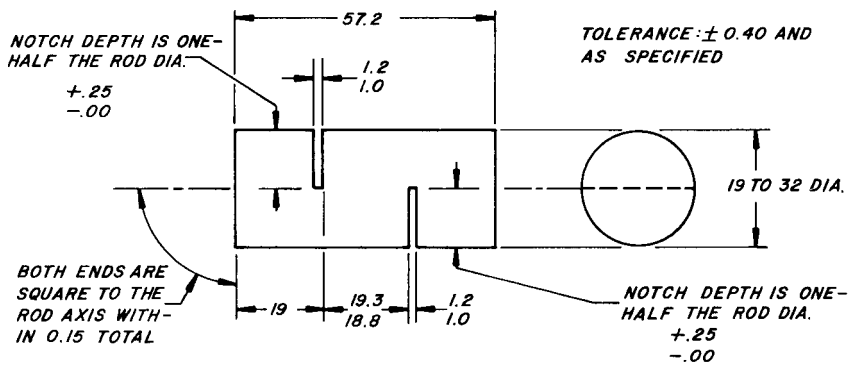

FIG. 1 Notched Rod In-Plane Shear Specimen; Dimensions: Top, mm; Bottom, in.

7. Test Specimens

7.1 *Configuration*—Test specimens shall be carefully machined from the rod sample of interest and shall conform to the shape and dimensions given in Fig. 1. The ends of the specimen shall be machined flat and parallel to prevent point loading upon application of the compressive load.

7.2 *Preparation*—After machining the specimen to proper length, insert it in the notching jig, flush it with one face of the jig, and tighten the cap screws of the jig to secure it in place. Push the assembly (jig and specimen) into a diamond grit cutoff wheel (or equivalent blade) after setting the blade to give the proper depth of notch. This arrangement is shown in Fig. 3. Guidance of the jig during specimen notching is by means of

sliding contact with the fence of the table saw as the jig is pushed along the table to a stop. After machining one notch, turn the tool over and repeat the procedure to provide a second notch in the specimen diametrically opposed to the first and at a fixed, defined distance (Fig. 1) from it.

NOTE 2—**Caution:** When fabricating composite specimens by machining operations, a fine dust consisting of particles of fibers or the matrix material, or both, may be formed. These fine dusts can be a health or safety hazard, or both. Adequate protection should be afforded operating personnel and equipment. This may require adequate ventilation or dust collecting facilities, or both, at a minimum.

7.3 *Number*—A minimum of five specimens shall be tested.

52TEI164		REV
NOTCHING JIG, IN-PLANE SHEAR		
NEXT ASSEM.		
DATE 9-16-77	BY	
TOLERANCE; $\pm 0.25\text{mm}$, $\pm 1/2^\circ$ AND AS SPECIFIED		
MATERIAL; ALUMINUM 2024-T 351 AND NOTED		
FINISH;		
REFERENCE	REV	
SPECIMEN 52TEA1193		

1. CHAMFER OUTSIDE CORNERS $0.8 \times 45^\circ$
2. THE TWO $45^\circ \pm 1/4^\circ$ SURFACES OF THE PRISMATIC HOLE ARE USED FOR GAGING AND MUST BE WITHIN THE SPECIFIED TOLERANCE
3. THE SIDES ARE SQUARE TO THE TOP AND BOTTOM WITHIN $\pm .10$
4. DIMENSIONS ARE IN MILLIMETRES AND SURFACE FINISH IS IN MICROMETRES

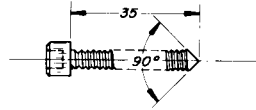
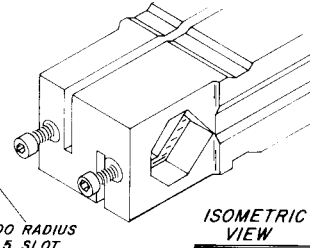

SCREW DETAIL
MAT'L: M6 - 1.00
SOC. HD. SCREW, STEEL

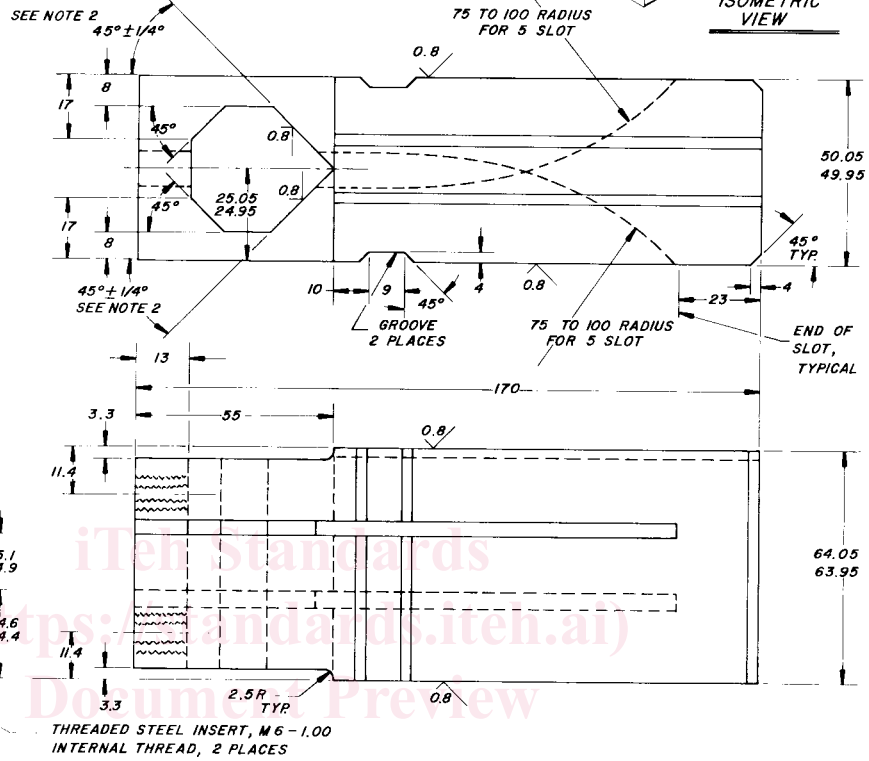
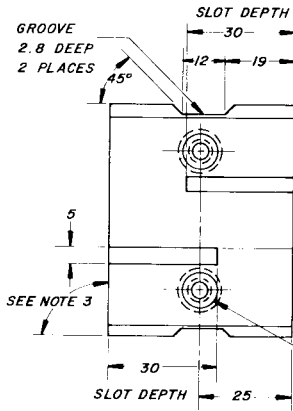

FIG. 2A Details of Specimen Notching Jig for In-Plane Shear Test, Dimensioned in mm

<https://standards.iteh.ai/catalog/standards/sist/e30b77bc-9805-4563-a903-d4c33cf2d126/astm-d3914-96>